

OPSC 2019

Odisha Public Service Commission

Civil Engineering

Objective Practice Sets

Structural Analysis

Contents

Sl. Topic	Page No.
1. Determinacy and Indeterminacy	2
2. ILD and Rolling Loads	10
3. Arches	17
4. Method of Indeterminate Analysis	24
5. Trusses	42
6. Matrix Method of Structural Analysis	51
7. Structural Dynamics and Cables	58



MADE EASY
Publications

Note: This book contains copyright subject matter to MADE EASY Publications, New Delhi. No part of this book may be reproduced, stored in a retrieval system or transmitted in any form or by any means. Violators are liable to be legally prosecuted.

Determinacy and Indeterminacy

- Q.1** The number of degrees of freedom of a point in space is
 (a) 3 (b) 6
 (c) 9 (d) unlimited number
- Q.2** The minimum number of overall equilibrium equations for plane truss analysis must be equal to
 (a) 2 (b) 3
 (c) 6 (d) unlimited number
- Q.3** The minimum number of equilibrium equations for a plane frame structural analysis must be equal to
 (a) 2
 (b) 3
 (c) 6
 (d) undefined number
- Q.4** The number of compatibility conditions needed in the analysis of a statically determinate structure are
 (a) 0 (b) 2
 (c) 3 (d) 6
- Q.5** Compatibility conditions are primarily governed by
 (a) strains (b) stresses
 (c) temperature (d) forces
- Q.6** Geometrically unstable structures can be used in
 (a) pin-connected systems
 (b) temporary systems
 (c) long spans
 (d) earthquake zones
- Q.7** If there are m unknown member forces, r unknown reaction components and j number of joints, then the degree of static indeterminacy of a pin-jointed plane frame is given by
 (a) $m + r + 2j$ (b) $m - r + 2j$
 (c) $m + r - 2j$ (d) $m + r - 3j$
- Q.8** A pin-jointed plane frame is unstable if
 (a) $(m + r) < 2j$ (b) $m + r = 2j$
 (c) $(m + r) > 2j$ (d) none of these
 where m is number of members, r is reaction components and j is number of joints
- Q.9** A rigid-jointed plane frame is stable and statically determinate if
 (a) $(m + r) = 2j$ (b) $(m + r) = 3j$
 (c) $(3m + r) = 3j$ (d) $(m + 3r) = 3j$
- Q.10** Consider the following statements:
 1. The displacement method is more useful when degree of kinematic indeterminacy is greater than the degree of static indeterminacy.
 2. The displacement method is more useful when degree of kinematic indeterminacy is less than the degree of static indeterminacy.
 3. The force method is more useful when degree of static indeterminacy is greater than the degree of kinematic indeterminacy.
 4. The force method is more useful when degree of static indeterminacy is less than the degree of kinematic indeterminacy.
 Which of these statements are correct?
 (a) 1 and 3 (b) 2 and 3
 (c) 1 and 4 (d) 2 and 4
- Q.11** Neglecting axial deformation, the kinematic indeterminacy of the structure shown in the figure below is:

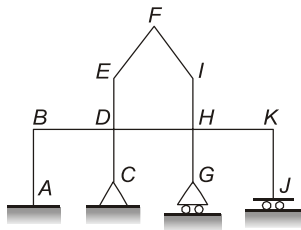

- (a) 12 (b) 14
(c) 20 (d) 22

Q.12 The degree of indeterminacy of the beam given below is

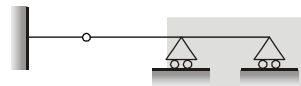

- (a) zero (b) one
(c) two (d) three

Q.13 What is the total degree of indeterminacy in the continuous prismatic beam shown in the figure below?



- (a) 1 (b) 2
(c) 3 (d) 4

Q.14 The degree of static indeterminacy of the hybrid plane frame as shown in figure is

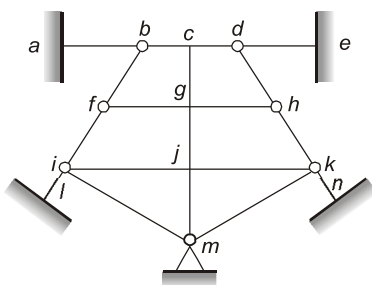

- (a) 10 (b) 11
(c) 12 (d) 13

Q.15 A plane frame *ABCDEFGH* shown in figure has a clamp support at *A*, hinge supports at *G* and *H*, axial force release at *C* and moment release (hinge) at *E*. The static (d_s) and kinematic (d_k) indeterminacies respectively are

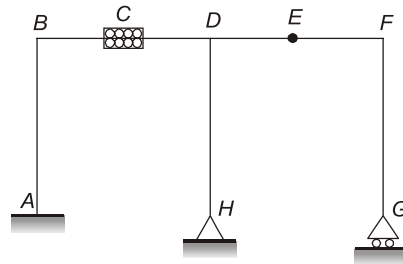

- (a) 4, 9 (b) 3, 11
(c) 2, 13 (d) 1, 14

Q.16 The statical indeterminacy for the given 3D frame is

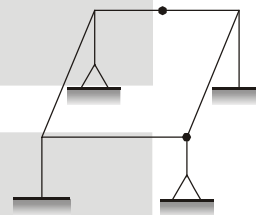

- (a) 8 (b) 6
(c) 9 (d) 12

Q.17 The plane pin-jointed structure shown in figure below is

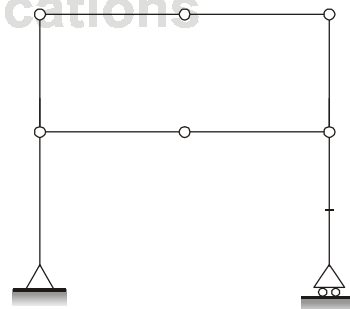

- (a) externally indeterminate
(b) internally indeterminate
(c) determinate
(d) mechanism

Q.18 Consider the following pin-jointed plane frames

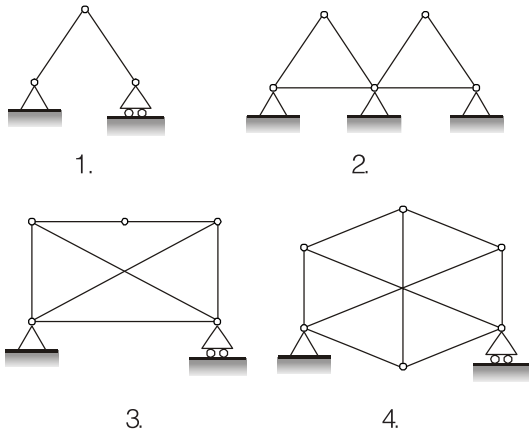

Which of these frames are stable?

- (a) 1, 2 and 3 (b) both 3 and 4
(c) 2, 3 and 4 (d) both 2 and 4

Q.19 A prismatic beam is shown in the figure given below.

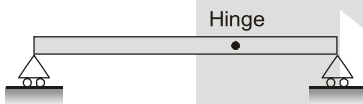

Consider the following statements:

1. The structure is unstable.
2. The bending moment is zero at supports and internal hinge.
3. It is a mechanism.
4. It is statically indeterminate.

Which of these statements are correct?

- (a) 1, 2, 3 and 4 (b) 1, 2 and 3
(c) 1 and 2 (d) 3 and 4

Q.20 The degree of static indeterminacy of the pin-jointed plane frame as shown in figure is

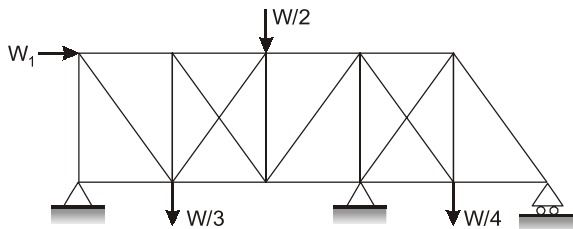

- (a) 1 (b) 2
(c) 3 (d) 4

Q.21 Match List-I (Structure) with List-II (Degree of static indeterminacy) and select the correct answer using the codes given below the lists:

List-I

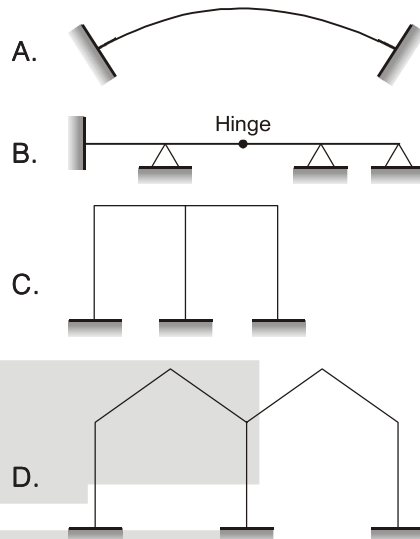

List-II

1. Three
2. Six
3. Two
4. Four

Codes:

	A	B	C	D
(a)	1	3	2	4
(b)	3	1	2	4
(c)	3	1	4	2
(d)	1	3	4	2

Q.22 What is the total degree of indeterminacy both internal and external of the plane frame shown below?

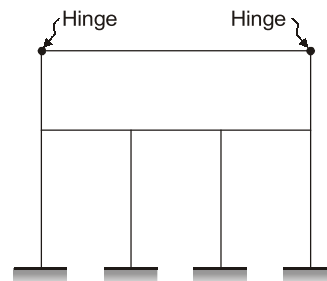

- (a) 10 (b) 11
(c) 12 (d) 14

Q.23 The static indeterminacy for the given 2D frame is

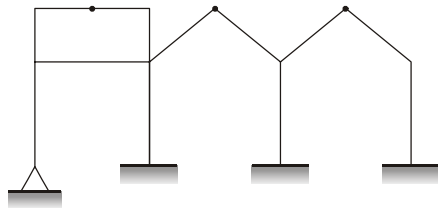

- (a) 8 (b) 6
(c) 9 (d) 11

Q.24 The degree of kinematic indeterminacy of frame shown in the figure ignoring the axial deformation is

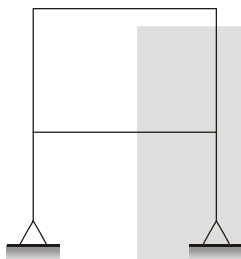

- (a) 8 (b) 10
(c) 12 (d) 14

Q.25 The total degree of static indeterminacy of the plane frame shown in given figure is

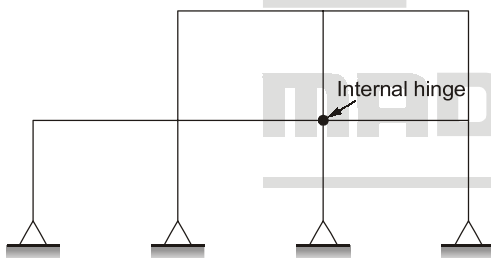

- (a) 10 (b) 11
(c) 12 (d) 15

Q.26 The degree of static indeterminacy for the beam as shown in figure is

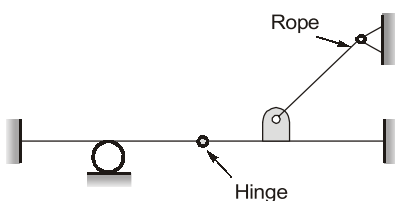

- (a) 1 (b) 4
(c) 5 (d) 3

Q.27 What is the kinematic indeterminacy for the frame shown below? (Members are in extensible)

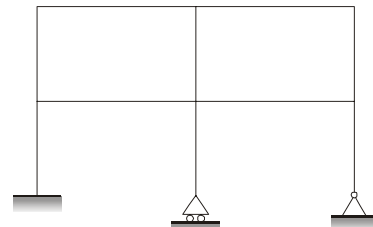

- (a) 6 (b) 11
(c) 12 (d) 21

Q.28 The total degree of indeterminacy of the pin-jointed truss shown below is

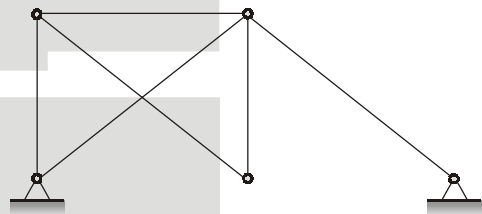

- (a) 0 (b) 1
(c) 2 (d) 3

Q.29 The static indeterminacy of the rigid frame shown is



- (a) 21 (b) 23
(c) 24 (d) 19

Q.30 What is the degree of kinematic indeterminacy of the plane structure shown in the figure below? (Members are inextensible)

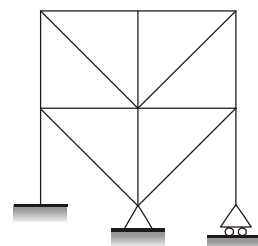

- (a) 6 (b) 7
(c) 8 (d) 10

Q.31 For the skeletal frame shown in the figure,

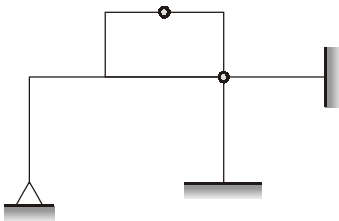

- (a) 1
- (b) 2
- (c) 3
- (d) 4

the static and kinematic indeterminacies, if all the members are inextensible, are

- (a) 3 and 13
- (b) 4 and 13
- (c) 3 and 14
- (d) 4 and 14

Q.32 The degree of static indeterminacy of the pin-jointed plane frame shown in figure.

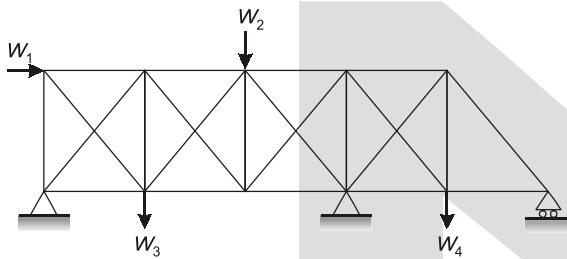

- (a) statically determinate
- (b) statically indeterminate to the first degree
- (c) statically indeterminate to the second degree
- (d) statically indeterminate to the third degree



Answers Determinacy and Indeterminacy

- 1. (b) 2. (b) 3. (b) 4. (a) 5. (a) 6. (b) 7. (c) 8. (a) 9. (c) 10. (d)
- 11. (b) 12. (b) 13. (d) 14. (d) 15. (c) 16. (c) 17. (c) 18. (c) 19. (b) 20. (d)
- 21. (a) 22. (a) 23. (d) 24. (a) 25. (c) 26. (b) 27. (b) 28. (a) 29. (c) 30. (b)
- 31. (d) 32. (d) 33. (c)

Explanations Determinacy and Indeterminacy

- 1. (b)
Six degrees of freedom are
 $\Sigma F_x = 0, \Sigma F_y = 0, \Sigma F_z = 0$ and,
 $\Sigma M_x = \Sigma M_y = \Sigma M_z = 0$
- 2. (b)
 $\Sigma F_x = 0, F_y = 0, M_z = 0$
- 7. (c)
Static Indeterminacy (D_s) and Kinematic indeterminacy (D_k)
1. Pin jointed 2-D(plane) frame
 $\Rightarrow D_s = m + r - 2j$
 $D_k = 2j - r$

2. Pin jointed space frame (3-D)

$$D_s = m + r - 3j$$

$$D_k = 3j - r$$

3. Rigid jointed plane frame (2-D)

$$D_s = 3m + r - 3j - \Sigma(m' - 1)$$

$$D_k = 3j - r - \Sigma(m' - 1)$$

$m' \rightarrow$ no. of members meeting at hybrid point.

4. Rigid jointed space frame (3-D)

$$D_s = 6m + r - 6j - \Sigma 3(m' - 1)$$

$$D_k = 6j - r - \Sigma 3(m' - 1)$$

8. (a)

For plane frame (pin jointed)

$m + r > 2j \rightarrow$ Indeterminate and over stiff

$m + r = 2j \rightarrow$ Stable and determinate

$m + r < 2j \rightarrow$ Unstable but determinate

9. (c)

For rigid jointed plane frame

$3m + R > 3j \rightarrow$ Indeterminate and over stiff

$3m + R = 3j \rightarrow$ Stable and determinate

$3m + R < 3j \rightarrow$ Unstable but determinate

10. (d)

Force method is useful when $D_s < D_k$,

Displacement method is useful when $D_k < D_s$.

11. (b)

Kinematic indeterminacy means degree of freedom of structure at various joints.

No rotation or translation is possible at A so degree of freedom at A is zero. There is a possibility of rotation at C but no translation so degree of freedom is one. At G, both rotation and translation is possible so degree of freedom is 2. At J no rotation but translation so d.o.f. is 1. At B, D, H and K there are 4 rotations and 1 translation so d.o.f. is 5. At E, F and I there are three rotations and two translations so d.o.f. is 5.

So kinematic indeterminacy

$$= 0 + 1 + 2 + 1 + 5 + 5 = 14$$

Alternate:

From direct formula

External reactions

$$r_e = 3 + 2 + 1 + 2 = 8$$

Number of members (m) = 11

Number of rigid joints (j) = 9

Number of hinged joints (j') = 2

There are no internal hinges so number of releases is zero.

$$r_r = 0$$

Degree of kinematic indeterminacy (assuming inextensible members).

$$D_K = 3(j + j') - (r_e + r_r) - m$$

$$= 3 \times (9 + 2) - 8 - 11$$

$$= 33 - 19 = 14$$

12. (b)

$$D_s = r_e + 3m - r_r - 3(j + j')$$

$$r_e = 3 + 1 + 1 = 5$$

$$m = 3, j = 3, j' = 1$$

The hinge will create 2 members.

Number of internal reaction components released.

$$r_r = 1.0$$

$$\therefore D_s = 5 + 9 - 1.0 - 3 \times (3 + 1) = 1.0$$

13. (d)

Total number of external reactions,

$$r_e = 3 + 1 + 1 + 3 = 8$$

Total number of equilibrium equations for inclined loading on the beam = 3

\therefore Total degrees of indeterminacy

$$= r_e - 3 = 8 - 3 = 5$$

Had this loading been vertical,

$$r_e = 2 + 1 + 1 + 2 = 6$$

Equilibrium equations = 2

\therefore Total degree of indeterminacy

$$= r_e - 2 = 6 - 2 = 4$$

14. (d)

$$D_s = D_{se} + D_{si}$$

$$D_{se} = r_e - 3 = 14 - 3 = 11$$

$$D_{si} = 3c - r_r$$

$$= 3 \times 6 - \Sigma(m_j - 1)$$

$$= 18 - (2 + 2 + 3 + 2 + 3 + 2 + 2)$$

$$= 18 - (16) = 2$$

$$\therefore D_s = 11 + 2 = 13$$