

2019

**RANK IMPROVEMENT  
WORKBOOK**

**Mechanical Engineering**

**Production Engineering**

Answer Key of Objective & Conventional Questions



**MADE EASY**  
Publications

# 1

## Metal Cutting

### LEVEL 1 Objective Questions

1. (52)
2. (c)
3. (b)
4. (c)
5. (b)
6. (2)
7. (28.57)
8. (b)
9. (5710)
10. (d)
11. (d)
12. (c)
13. (3.1)
14. (d)
15. (c)
16. (0.238)
17. (41.23)
18. (31.85)
19. (b)
20. (1.06)

© Copyright: Subject matter to MADE EASY Publications, New Delhi. No part of this book may be reproduced or utilised in any form without the written permission.

### LEVEL 2 Objective Questions

21. (335.2)
22. (55.64)
23. (18.4)
24. (b)
25. (c)
26. (a)
27. (c)
28. (65.42)
29. (b)
30. (a)
31. (c)
32. (c)
33. (21.8)
34. (b)

■ ■ ■ ■

**LEVEL 3** Conventional Questions

**Solution : 35**

$$\tau_s = 742 \text{ MPa}$$

**Solution : 36**

$$\begin{aligned}\phi &= 17.88^\circ \\ V_s &= 3.313 \text{ m/s} \\ W_s &= 828.81 \text{ W} \\ F &= 1294.64 \text{ N} \\ V_c &= 1.033 \text{ m/s} \\ W_F &= 1.337 \text{ kW} \\ W_T &= 2.166 \text{ kW}\end{aligned}$$

**Solution : 37**

$$\begin{aligned}\phi &= 36.7^\circ \\ F_s &= 267.72 \text{ N} \\ F_c &= 429.379 \text{ N} \\ F_T &= 127.75 \text{ N}\end{aligned}$$

**Solution : 38**

$$\phi = 18.34^\circ$$

**Solution : 39**

$$\begin{aligned}F_s &= 366.8 \text{ N} \\ \tau_s &= 236.1 \text{ MPa} \\ \text{Power consumption, } W &= 1134 \text{ W} \\ \text{Chip velocity, } V_c &= 1.114 \text{ m/s} \\ \text{Shear strain, } \gamma &= 2.036\end{aligned}$$

**Solution : 40**

**Face wear (Crater wear):**

- On the face of the tool there is a direct contact of tool with the chip. Wear takes the form of cavity or crater, which has its origin above the cutting edge. With time, cavity goes on widening. This is prominent in ductile materials. The crater occurs on the rake face of the tool at the point of impingement of the chip with tool and does not actually reach the cutting edge but ends near the nose and on the periphery which serves as the focal points of development of crack and extends to the cutting edge causing a rapid rupture. It leads to weakening of tool, increase in cutting temperature, friction and cutting forces. The tool life due to crater wear can be determined by fixing the ratio of width of crater to its depth.

**Flank wear (Edge wear):**

- This wear is also called "wearland". Work and tool are in contact at cutting edge only. Usually wear first appears on the clearance face of the tool in the form of a wear land, and is mainly the result of friction and abrasion.
- Adhesion is also a factor because welding of the tool to the work material causes a built-up edge which is torn away, taking particles of the tool material with it. Thermal cracking, due to thermal shock, is also a cause of breakdown of small particles, leading to flank or edge wear.

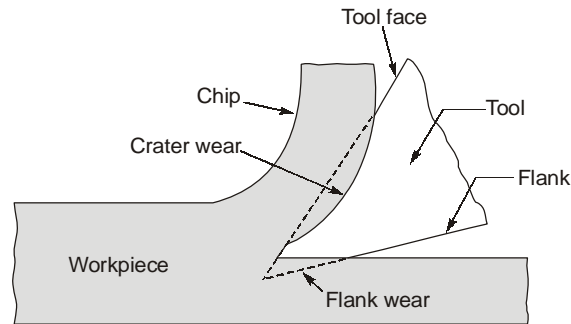

- Flank wear starts at cutting edge and then starts widening along the clearance face. It is independent of cutting conditions and tool/work materials. Crater wear is prominent in ductile metals, but the flank wear becomes predominant in materials having brittle and flaky chip and discontinuous chip. It is important even in ductile materials if surface finish is the main criteria.
- While all other modes of tool failure can be effectively reduced by changing speed, feed or depth of cut, the flank wear is a progressive form of deterioration which will ultimately result in failure inspite of best precautions.

$$n = 0.46; \quad \therefore c = 50(45)^{0.46} = 288.04$$

$$T_0 = 2.3478, \text{om}$$

$$V_0 = 194.5 \text{ m/min}$$

**Solution : 41**

$$\begin{aligned} \text{Cutting force} &= 10 \text{ kN} \\ \text{Depth of cut} &= 12.5 \text{ mm} \end{aligned}$$

**Solution : 42**

$$\begin{aligned} \phi &= 33.4^\circ \\ F_s &= 349.25 \text{ N} \\ \tau_s &= 197.18 \text{ MPa} \end{aligned}$$

Power for cutting operations:

$$\begin{aligned} P &= 1140 \text{ W or } 1.14 \text{ kW} \\ \gamma &= 1.9493 \\ V_s &= 2.146 \text{ m/s} \\ \text{Strain rate} &= 78755.4 \text{ s}^{-1} \end{aligned}$$



# 2

## Metal Forming

### LEVEL 1 Objective Questions

1. (d)
2. (12.56)
3. (98)
4. (643.77)
5. (64.05)
6. (c)
7. (d)
8. (c)
9. (a)
10. (d)
11. (d)
12. (a)
13. (d)
14. (c)
15. (b)
16. (c)
17. (d)
18. (b)
19. (b)

© Copyright: Subject matter to MADE EASY Publications, New Delhi. No part of this book may be reproduced or utilised in any form without the written permission.

20. (b)

21. (a)

22. (d)

23. (c)

24. (c)

25. (a)

### LEVEL 2 Objective Questions

26. (c)

27. (153.15)

28. (10.12)

29. (b)

30. (a)

31. (b)

32. (d)

33. (26.257)

34. (1.116)

35. (8.97)

36. (-75)

37. (d)

38. (c)

**39.** (3)**40.** (7.408)**41.** (b)**42.** (313.50)**43.** (d)**44.** (c)

■■■■

© Copyright: Subject matter to MADE EASY Publications, New Delhi. No part of this book may be reproduced or utilised in any form without the written permission.

**LEVEL 3** Conventional Questions

**Solution : 45**

$$\begin{aligned} \text{Die size} &= 10.1 \text{ mm} \\ \text{Force required} &= 7.536 \text{ kN} \\ \text{Punch size} &= (49.9 \times 199.9) \text{ mm} \\ \text{Force required} &= 120 \text{ kN} \end{aligned}$$

**Solution : 46**

$$\begin{aligned} \alpha &= 18.195 \\ \% \text{ reduction in thickness} &= 16.67\% \\ \text{Elongation coefficient} &= 1.19 \end{aligned}$$

**Solution : 47**

$$\begin{aligned} \sigma_d &= 142.183 \text{ N/mm}^2 \\ F_d &= 7.8 \text{ kN} \\ P_{\text{motor}} &= 20.53 \text{ kW} \end{aligned}$$

**Solution : 48**

$$R = 0.9648$$

**Solution : 49**

- (i) Highest possible reduction =  $t_1 - t_2 = 60 - 42 = 18 \text{ mm}$
- (ii) Length of contact on rolls = 60.23 mm
- (iii) Rolling load = 3010.365 kN

**Solution : 50**

- (i) Power required in drawing = 44.3297 kW
- (ii) For maximum reduction = 0.747  
Percentage reduction in diameter = 25.3%
- (iii) Back pressure = 50 N/mm<sup>2</sup>  
reduction in area = 41.4%

**Solution : 51**

$$\begin{aligned} \text{Percent reduction required} &= 66.67\% \\ \text{Maximum reduction permitted in single draw} &= 40\% \end{aligned}$$

**Solution : 52**

$$F = 3602.5 \text{ N/mm} = 0.54 \times 10^6 \text{ N}$$

**Solution : 53**

- (i) 30% percent reduction in area is given  
Drawing load = 11.217 kN
- (ii) Hence power required =  $\frac{25.80}{0.98} = 26.326 \text{ kW}$

**Solution : 54**

$$\begin{aligned} \text{Checking for sticking} &= -26.23 \text{ mm} \\ \text{mean flow stress} &= 1081.13 \text{ MPa} \\ \text{forging load} &= 51.72 \text{ MN} \end{aligned}$$



**LEVEL 1** Objective Questions

1. (10)
2. (28.76)
3. (a)
4. (b)
5. (d)
6. (a)
7. (d)
8. (a)
9. (b)
10. (a)
11. (b)
12. (30.28)
13. (b)
14. (40)
15. (b)

© Copyright: Subject matter to MADE EASY Publications, New Delhi. No part of this book may be reproduced or utilised in any form without the written permission.

**LEVEL 2** Objective Questions

16. (7.872)
17. (1.539)
18. (4.699)
19. (13.7)
20. (b)
21. (a)
22. (c)
23. (b)
24. (a)
25. (1.889)
26. (c)
27. (c)
28. (314.3115)
29. (a)
30. (a)
31. (b)

■■■■



**LEVEL 3** Conventional Questions

**Solution : 32**

$$= 1.4978$$

**Solution : 33**

$$= 6.8689 \text{ s}$$

$$\text{Total time to full the casting} = 34.45 \text{ s}$$

**Solution : 34**

$$(i) = 2.232 \text{ s/mm}^2$$

$$(ii) T_{TS} = 1.24 \text{ min}$$

**Solution : 35**

Round Casting:

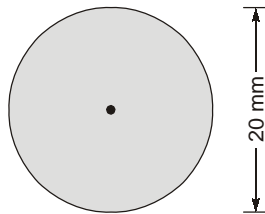

Elliptical Casting:

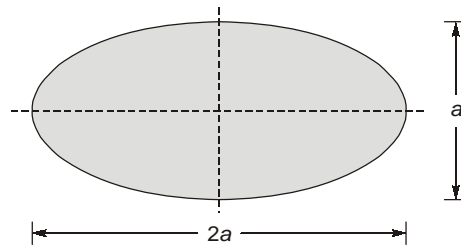

$$\frac{t_c}{t_E} = 0.469$$

**Solution : 36**

**Chaplet:** Chaplets are used to support cores inside the mould cavity to take care of its own weight and overcome the metallostatic forces.

**Resin Binder:** Resin binder are used in the core sand to provide proper strength to the core.

**Merits and Demerits of shell moulding:**

**Merits:**

1. Shell-mould casting are generally more dimensionally accurate than sand casting.
2. A smoother surface can be obtained in shell casting. This is primarily achieved by the finer size grains used.
3. Draft angles, which are lower than the sand casting are required in shell moulds. The reduction in draft angle may be from 50 to 75%, which considerably saves the material costs and the subsequent machining costs.

**Demerits:**

1. The patterns are very expensive and therefore are economical only if used in large scale production.

2. The size of the casting obtained by shell moulding is limited. Generally, castings weighing up to 200 kg can be made, though in smaller quantity, casting upto a weight of 450 kg are made.
3. Highly complicated shapes cannot be obtained.
4. More sophisticated equipment is needed for handling the shell mouldings.

**Solution : 37**

$$(t_{\text{cylindrical riser}})_{\text{optimum}} = 1.174 (t_{\text{paralleloiped riser}})_{\text{optimum}}$$

**Solution : 38**

$$d = 128.4 \text{ mm}$$

**Solution : 39**

$$\text{Volume of the riser} = 2872.95 \text{ cm}^3$$



**LEVEL 1** Objective Questions

1. (c)
2. (d)
3. (a)
4. (a)
5. (d)
6. (5625)
7. (27)
8. (a)
9. (894.427)
10. (b)
11. (c)
12. (0.680)
13. (9.377)
14. (d)
15. (d)
16. (0.5)
17. (33.674)

© Copyright: Subject matter to MADE EASY Publications, New Delhi. No part of this book may be reproduced or utilised in any form without the written permission.

**LEVEL 2** Objective Questions

18. (b)
19. (c)
20. (b)
21. (d)
22. (c)
23. (c)
24. (2128.56) (2125 to 2131)
25. (6000)
26. (b)
27. (b)
28. (155.48)(155 to 156)
29. (41.3534)
30. (c)
31. 202.171 (195-205)
32. (b)

■ ■ ■ ■

**LEVEL 3** Conventional Questions**Solution : 33**

Change in power = 7200 W

arc length,  $l_a = 1.5$  mm

**Solution : 34**

- (i) **Porosity:** Porosity in welding is caused by the presence of gases which get entrapped during the solidification process. The main gases that caused porosity are hydrogen, oxygen and nitrogen. Porosity if present in large would reduce the strength of the joint.

**Remedies:**

- Slowing the welding speed to allow time for the gases to escape.
- Proper cleaning and preventing the contaminants from entering the weld.
- Proper selection of electrodes and filler materials.

- (ii) **Slag inclusion:** Slag is formed by the reaction with the fluxes and is generally lighter, so it will float on top of the weld pool and would be chipped off after solidification. However the stirring action of the high intensity arc would force the slag to go into the weld pool and if there is not enough time for it to float, it may get solidified inside the fusion zone and end up as a slag inclusion. Also in multipass welding, the slag solidified in the previous pass is not cleaned before depositing the next bead, which may cause slag inclusion.

**Remedies:**

- Cleaning the weld bead surface before the next layer is deposited by using a hand or power wire brush.
- Redesigning the joint to permit sufficient space for proper manipulation of the puddle of molten weld metal.

- (iii) **Incomplete fusion and penetration:** The main causes for this defect are improper penetration of the joint, wrong design of the joint or incorrect welding technique including the wrong choice of the welding parameters. The welding current if, is lower than required would not sufficiently heat all the faces of the joint to promote proper fusion. Also, the improper cleaning of the joint hinders the fusion of the metal in the joint.

**Remedies:**

- Increasing the heat input
- Changing the joint design
- Ensuring that the surfaces to be joined fit properly.
- Proper cleaning of the joint

- (iv) **Hot cracking:** This generally occurs at high temperature and the size can be very small to be visible. The crack in most parts is intergranular and its magnitude depends upon the strains involved in solidification. They are more likely to form during the root pass when the mass of the base metal is very large compared to the weld deposited.

**Remedies:**

- Preheating the base metal, increasing the cross sectional area of the root bead, or by changing the contour or composition of the weld bead.

**Solution : 35**

Depth of weld = 3.849 mm

**Solution : 36**

(i) **Short Circuiting metal transfer:** The short-circuiting metal transfer occurs with relatively low current settings of the order of 75 to 175 A for an electrode diameter of 0.9 mm.

The main advantage of using the short-circuit metal transfer is the lower penetration, which can be effectively used for welding thin sheets. Poorly fit joint as well as difficult-to-reach positions (such as over head) can also be successfully welded.

Practically, there is no spatter since the metal is transferred only when the electrode touches the workpiece. Also, less amount of metal is affected around the weld joint because of the smaller heat input.

**Transition current:** The value of current at which the metal transfer changes from one type of another type is termed as transition current.

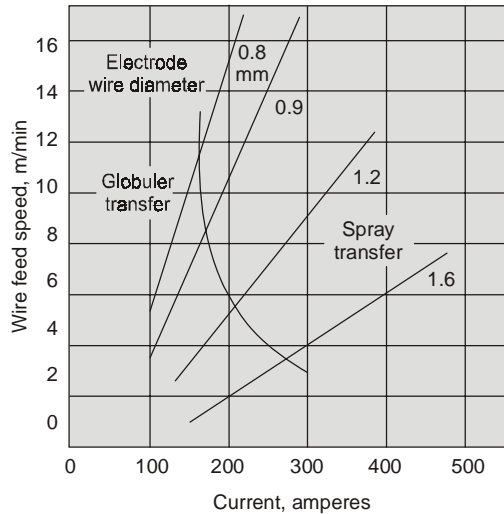

The current at which the metal transfer changes from globular to spray type is termed as the globular to spray transition current.

**Solution : 37**

Gas Metal Arc Welding (GMAW), sometimes referred to by its subtypes Metal Inert Gas (MIG) Welding or Metal Active Gas (MAG) Welding, is a semiautomatic or automatic arc welding process in which a continuous and consumable wire electrode and a shielding gas are fed through a welding gun. A constant voltage, direct current power source is most commonly used with GMAW, but constant current systems, as well as alternating current, can be used. There are four primary methods of metal transfer in GMAW, called globular, short-circuiting, spray, and pulsed-spray, each of which has distinct properties and corresponding advantages and limitations.

Originally developed for welding aluminum and other nonferrous materials in the 1940s, GMAW was soon applied to steels because it allowed for lower welding time compared to other welding processes. The cost of inert gas limited its use in steels until several years later, when the use of semi-inert gases such as carbon dioxide became common. Further developments during the 1950s and 1960s gave the process more versatility and as a result, it became a highly used industrial process. Today, GMAW is the most common industrial welding process, preferred for its versatility, speed and the relative ease of adapting the process to robotic automation. The automobile industry in particular uses GMAW welding almost exclusively. Unlike welding processes that do not employ a shielding gas, such as shielded metal arc welding, it is rarely used outdoors or in other areas of air volatility. A related process, flux cored arc welding, often does not utilize a shielding gas, instead employing a hollow electrode wire that is filled with flux on the inside.

**Diffusion Bonding/Welding:** Diffusion bonding or welding is a solid state process wherein coalescence of the laying surfaces is produced by the application of pressure and elevated temperatures to carefully cleaned and mated metal surfaces so that they actually grow together by atomic diffusion.

The process does not involve macroscopic deformation or relative motion of the parts. The process can join either similar or dissimilar metals with or without the use of another material in between.

**Theory of Diffusion Welding:** Diffusion welding process involves two steps or stages:

1. Any surface to be diffusion welded or otherwise is never extremely smooth. It has a number of peak points and valleys. Moreover, this surface may have, (i) An oxidized layer, (iii) Absorbed gas, moisture or both. The first stage is to achieve intimate metal to metal contact between the two pieces to be diffusion welded. This is done by the application of pressure that deforms the substrate roughness and disrupts and disperses the above mentioned surface layers and contaminants. The pressure applied in diffusion welding ranges from 350 to 700 kg/cm<sup>2</sup>.
2. The second stage involves diffusion and grain growth to complete the weld and ultimately eliminate the interface formed in the previous stage. The second stage induces complete metallic bonding across the area of contact. In order to increase diffusion rate, moderate heating temperatures (usually below 1100°C) are used. Without applying heat it takes many hours to perform a certain bonding, with the application of heat, the time element can be cut to a few hours or minutes. (a) Two typical workpiece surfaces to be diffusion welded can be seen. (b) The individual peaks and valleys (or asperities) which make up the roughness are deformed by the application of increasing pressure. (c) At places where the surfaces move together under shear, the (oxide) films are disrupted and metal to metal contact takes place.

The oxide films dissolve in the metals such as titanium, tantalum, columbium, zirconium etc. In aluminium they do not do so and thus the disruption process for the trapped films is spheroidization. This process leaves a few oxide particles along the weld line. Both dissolution and spheroidization require diffusion to complete. (d) After metal to metal contact is established, the atoms are within the attractive force fields of each other (and hence a high strength joint is generated). The joint resembles a grain boundary. (e) A planer interfacial boundary being thermodynamically unstable, tends to migrate to a more stable configuration if conditions permit.

### Gas Tungsten Arc Welding (GTAW) or Tungsten Inert Gas Welding (TIG)

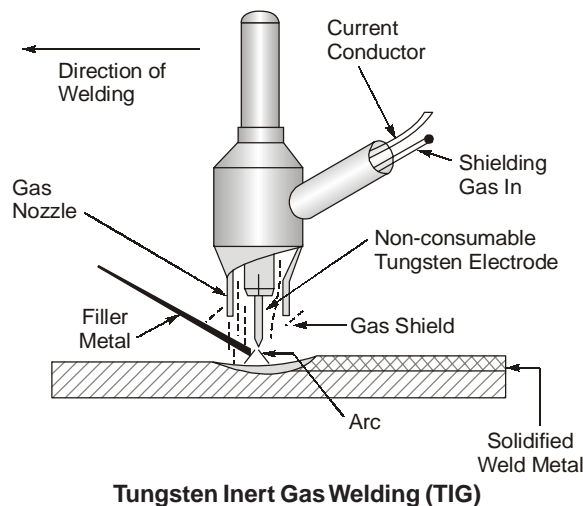

In GTAW process the electrode is non consumable and the purpose of it is only to create an arc. A separate filler metal rod is used to deposit the material. This was primarily invented to weld alloys of Aluminium and Magnesium. Aluminium is very difficult to weld because as soon as it is exposed to atmosphere it forms a layer over it. To weld these materials work piece should be given negative polarity and electrode positive polarity. As the electrons are coming out of the work piece, peels of the ceramic layer and fresh Aluminium comes in contact with the arc. This phenomenon is called cathodic cleaning. Wherever electron bombards two-third heat will be generated, one-third heat is generated at the negative electrode and in case of GTAW when more heat is produced at the tungsten electrode it gets eroded and tungsten particles mixes with the bead making it brittle.

A pool of inert gases like Helium and Argon provides the protective covering to the molten metal. This reverse polarity is also used to weld very thin sheets because when the development of heat over work piece material is more, holes will be produced in the material and there will not be any welding. The torches for carrying current beyond 100 amperes are usually water cooled. Arc initiation is normally done by touching the electrode on a graphite block. The gas nozzle of a GTAW torch is its weakest part and is fastened to the torch body by threaded connection. These nozzles are generally made of ceramic material.

This process is used to weld in all positions and is extensively used for welding aluminium, magnesium, stainless steels, copper, Nimonic alloys, Monel, inconel etc. It is especially used in aircraft industry, chemical plant and nuclear plant.

**Solution : 38**

Percentage of heat goes unutilised i.e., 49.386% energy goes to parent metal by conduction, and 50.614% of heat energy is utilized for welding.

**Solution : 39**

Efficiency of the welding = 65.4%.

**Solution : 40**

Advantages of SAW process are :

- Since it uses bare wire consumable electrodes, welding speeds and deposition rates are high and thus long and circumferential joints can be welded conveniently.
- Weld spatter is eliminated and no shielding is required to protect operator.
- Flux acts as deoxidizer and scavenger to remove undesirable contaminants.
- Process can be semi-automatic or automatic offering several inherent advantages.
- Motor generators, rectifiers or transformers with constant current or constant voltage output characteristics can be used.

**Limitations are:**

- Extra equipment to handle flux and work holding fixture needed.
- Flux is subjected to contamination and may cause weld porosity.
- Not suitable for thin metals because of burn out and for cast irons, Al and Mg alloy, lead etc. as they can't withstand thermal stresses.
- Restricted to flat position for groove welds and horizontal positions for fillet welds.
- Because of high current, some metallurgical considerations pose limitations.

**Solution : 41**

In friction welding the heat required for welding is generated through friction at the interface of the two components being joined. In this process, one of the components remains stationary while the other is

placed in a chuck or collet and rotated at a high constant speed. The two members to be joined are then brought into contact under an axial force. After sufficient contact is established, the rotating members is brought to a quick stop, while the axial force is increased. Oxides and other contaminants at the interface are removed by the radially outward movement of the hot metal at the interface. The pressure at the interface and the resulting friction produce sufficient heat for a strong joint to form.

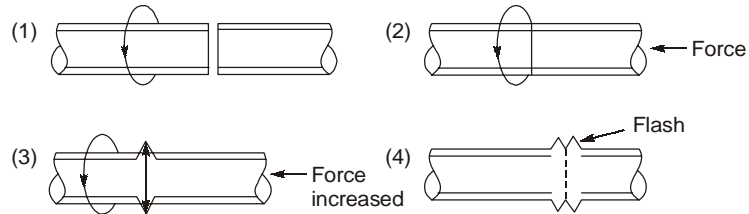

The shape of the welded joint depends on the rotational speed and on the axial pressure applied. These factors must be controlled to obtain a uniformly strong joint. The modification of friction welding to control these parameters are inertia friction welding and friction stir welding processes.

Low hydrogen electrodes contains very less amount of hydrogen in electrode composition. These electrodes are required to minimize the possibility of hydrogen related cracking. These electrodes also provide weld deposits exhibiting a high minimum level of notch toughness. These electrodes have coatings comprised of materials that are very low in hydrogen.

**Numerical:** Let  $I$  be the maximum output current that can be drawn at 100% duty cycle.

As

$$I^2 D = \text{constant}$$

$$I^2 \times 1 = (600)^2 \times 0.6$$

$$I = 464.758 \text{ A.}$$





# 5

## Non-Conventional Machining

### LEVEL 1 Objective Questions

1. (c)
2. (b)
3. (b)
4. (c)
5. (c)
6. (d)
7. (d)
8. (a)
9. (b)
10. (a)
11. (c)
12. (d)
13. (d)

© Copyright: Subject matter to MADE EASY Publications, New Delhi. No part of this book may be reproduced or utilised in any form without the written permission.

### LEVEL 2 Objective Questions

14. (b)
15. (301)
16. (2240.178)
17. (0.0175)
18. (d)
19. (c)
20. (d)
21. 1378.5 (1375 to 1380)
22. (c)
23. (d)
24. (b)

■■■■

**LEVEL 3** Conventional Questions
**Solution : 25**

Let the discharge voltage be  $v_d$ .

Then, the charging voltage be  $v_o$ .

As,  $v_d = v_o(1 - e^{-t/RC})$

Let the charging time be  $t_1$

Then, discharge time is  $t_2$

Energy released per spark

$$E = \frac{1}{2} C v_d^2$$

Average power delivered,

$$P_{\text{avg}} = \frac{E}{t_1 + t_2}$$

As,  $(t_2 \ll t_1)$ , so,

$$P_{\text{avg}} = \frac{E}{t_1}$$

$$P_{\text{avg}} = \frac{1}{2t_1} C v_d^2$$

$$= \frac{1}{2t_1} \times C \times v_o^2 (1 - e^{-t_1/RC})^2 = \frac{1}{2} \frac{RC}{R t_1} \times v_o^2 (1 - e^{-t_1/RC})^2$$

Assume,  $\frac{t_1}{RC} = x$

$$P_{\text{avg}} = \frac{1}{2} \frac{v_o^2}{R x} (1 - e^{-x})^2$$

For maximum power delivery,

$$\frac{dP_{\text{avg}}}{dx} = 0$$

By solving, we get  $x = 1.26$

So, optimum discharge voltage,

$$v_d = v_o(1 - e^{-x}) = v_o(1 - e^{-1.26}) = 0.72 \times v_o$$

∴ Discharge voltage is 72% of supply voltage.

Variation of MRR with the following parameters:

1. Variation in resistance and capacitance - with the increase in resistance and capacitance of circuit, MRR decreases.
2. With the increase in mean current, MRR increases.
3. With the change in spark gap, MRR decrease as there is optimum spark gap that needs to be maintained.

**Solution : 26**

$$I = 358.42 \approx 358 \text{ A}$$

**Solution : 27**

This is the process of metal removal by controlled dissolution of the anode of an electrolytic cell. The tool is cathode and work is anode. The tool advances towards the anode through the electrolyte and metal is removed from work through electrical action. The electrolyte is pumped at high pressure through the gap to conduct current and carry heat. Metal removal rate is independent of work hardness, strength and thermal properties. Metal removal rate depends on Atomic weight and valency. Electrolyte is so chosen that only anode is dissolved but no deposition takes place on cathode. The tool is made of Copper, Brass, Steel. Practically there is no tool wear. This process is used for machining any conducting material, complex profile like turbine blades, nozzles, complex cavities in high strength materials, drilling holes, die sinking etc.

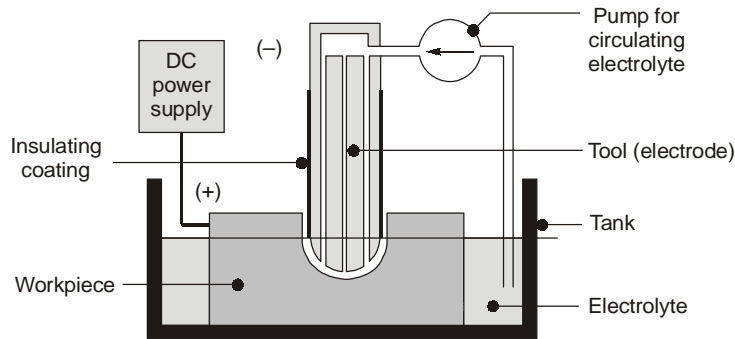

Fig. Schematic illustration of the electro-chemical machining process

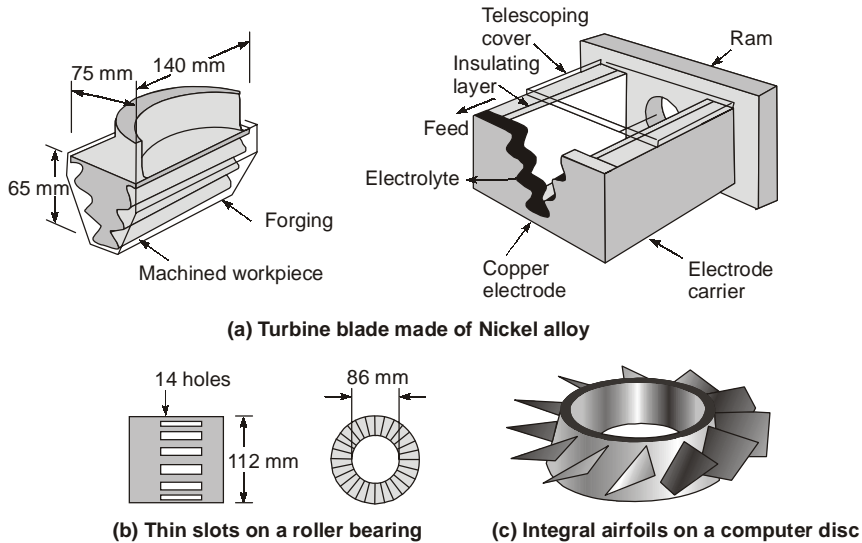

Fig. Typical parts made by ECM

**Alloy Machined**

- Iron based
- Ni Based
- Ti based
- Co-Cr-W based
- WC based

**Electrolyte**

- Chloride solution in water (20% NaCl)
- HCl (or) mixture of brine and  $H_2SO_4$
- 10% HF + 10% HCl + 10%  $HNO_3$
- NaCl
- Strong alkaline solution

**Solution : 28**

- (a) Laser is highly coherent beam of electromagnetic radiation with wavelength varying from  $0.1 \mu\text{m}$  to  $70 \mu\text{m}$ .

As the rays of laser beam are perfectly parallel and monochromatic, it can be focussed to a very small diameter and can produce a power density upto  $10^7 \text{ W/mm}^2$ .

A coiled xenon flash tube is placed around the ruby rod and the internal surface of the container walls is made highly reflecting so that maximum light falls on the ruby rod for the pumping operation. The capacitor is charged and a very high voltage is applied to the triggering electrode for initiator of the flash. The emitted laser beam is focused on the work surface removing a small portion of material by vapourization.

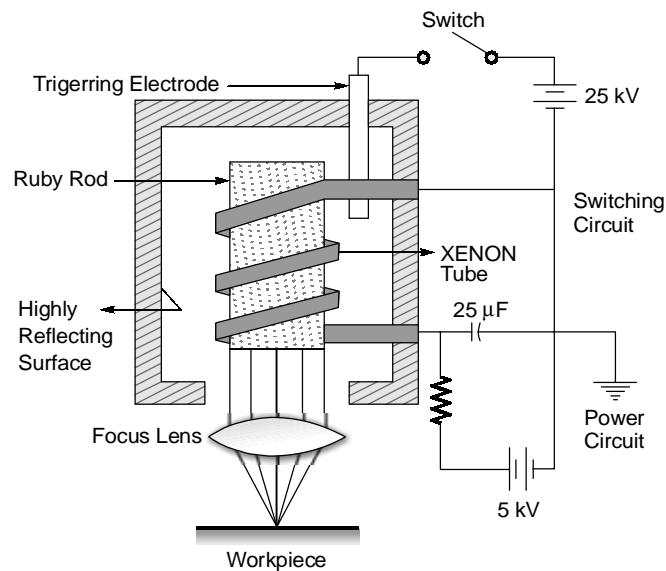

- (b) **Mechanics of LBM:**

Machining by laser beam is achieved through following phases.

- (i) interaction of laser beam with work material.
- (ii) heat conduction and temperature rise.
- (iii) melting, vaporization and ablation.

The application of laser beam depends upon the thermo-optic interaction between the laser beam and w/p. The surface should not reflect back too much of incident beam energy.

The absorbed light is propagates into the medium and its energy is gradually transferred to the lattice atoms in the form of heat.

The incident beam thus heats up the surface quickly and hence vapourizes it.

It can be used for drilling fine holes and machining zig-zag cavities.

- (c) MRR in USM depends upon following parameters.

- (i) If static loading is increased, MRR tends to increase but after a certain value of the force, the grain starts getting crushed.

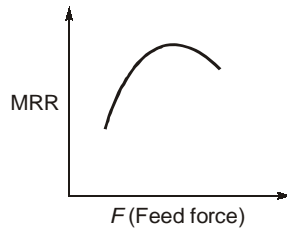

(ii) When amplitude of vibration is increased, MRR increases.

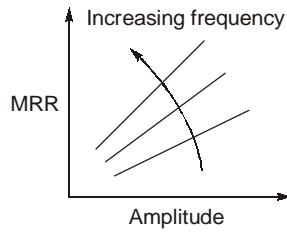

(iii) MRR rise proportionately with the mean grain diameter ( $d$ ) but when ' $d$ ' becomes too large, crushing tendency increases and MRR, decreases

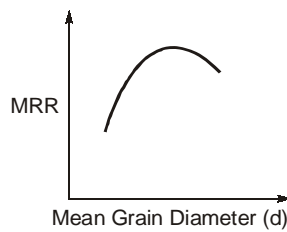

This process can be used to produce holes on glass, for dental operations and for machining refractory materials.

**Solution : 29**

EDM is an advanced machining process primarily used for hard and difficult metals which are difficult to machine with the traditional techniques. Only electrically conducting materials are machined by this process. The EDM process is best suited for making intricate cavities and contours which would be difficult to produce with normal machines like grinders, end-mills or other cutting tools. Metals such as hardened tool-steels, carbides, titanium, inconel and kovar are easily machined through EDM.

EDM is a thermal process which makes use of spark discharges to erode the material from workpiece surface. The cavity formed in EDM is a replica of the tool shape used as the erosions occur in the confined area. Since spark discharges occur in EDM, it is also called as "spark machining". The material removal takes place in EDM through a rapid series of electrical discharges. These discharges pass between the electrode and the workpiece being machined. The fine chips of material removed from the workpiece gets flushed away by the continuous flowing di-electric fluid. The repetitive discharge creates a set of successively deeper craters in the work piece until the final shape is produced.

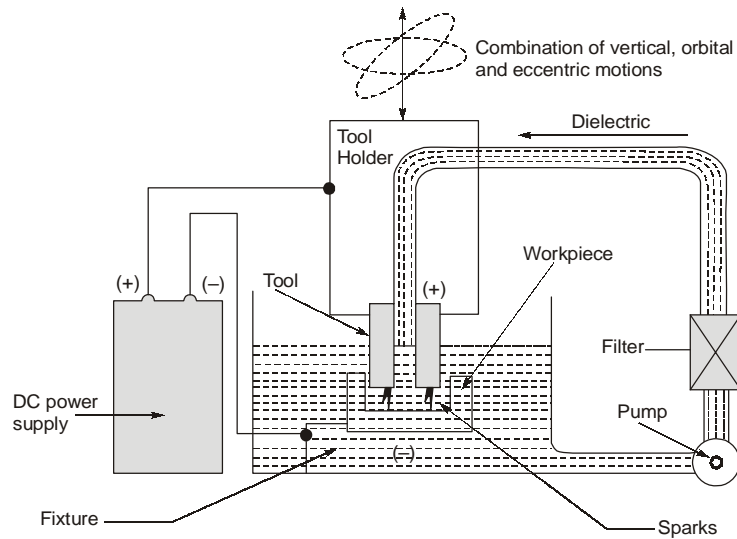

Schematic of Electro Discharge Machining Process

### Advantages of EDM

The major advantages of the process are:

- Any materials that are electrically conductive can be machined by EDM.
- Materials, regardless of their hardness, strength, toughness and microstructure can be easily machined/ cut by EDM process
- The tool (electrode) and workpiece are free from cutting forces
- Edge machining and sharp corners are possible in EDM process
- The tool making is easier as it can be made from softer and easily formable materials like copper, brass and graphite.
- The process produces good surface finish, accuracy and repeatability.
- Hardened work-pieces can also be machined since the deformation caused by it does not affect the final dimensions.
- EDM is burr free process.

### Applications of EDM

- Hardened steel dies, stamping tools, wire drawing and extrusion dies, header dies, forging dies, intricate mould cavities and such parts are made by the EDM process.
- The process is widely used for machining of exotic materials that are used in aerospace and automotive industries.
- EDM being a non-contact type of machining process, it is very well suited for making fragile parts which cannot take the stress of machining. The parts that fit such profiles include washing machine agitators; electronic components, printer parts and difficult to machine features such as the honeycomb shapes.
- Deep cavities, slots and ribs can be easily made by EDM as the cutting forces are less and longer electrodes can be used to make such collates, jet engine blade slots, mould cooling slots etc.
- Micro-EDM process can successfully produce micro-pins, micro-nozzles and micro-cavities.

### Limitations of EDM

- Material removal rates are low, making the process economical only for very hard and difficult to machine materials.

- Re-cast layers and micro-cracks are inherent features of the EDM process, thereby making the surface quality poor.
- The EDM process is not suitable for non-conductors.
- Rapid electrode wear makes the process more costly.
- The surfaces produced by EDM generally have a matte type appearance, requiring further polishing to attain a glossy finish.

**Solution : 30**

On solving  $x = 84.15\%$

**Solution : 31**

$$\text{MRR} = \frac{27.925 \times 1000}{96500 \times 7.86} = 0.0368 \text{ cm}^3/\text{sec}$$
$$\text{Electrode Feed rate} = 0.0060287 \text{ cm/sec}$$



# 6

## Metrology and Inspection

### LEVEL 1 Objective Questions

1. (a)
2. (b)
3. (b)
4. (a)
5. (a)
6. (c)
7. (-0.4117)
8. (d)
9. (b)
10. (c)
11. (c)
12. 25.05 (24.95 to 25.15)
13. (b)
14. (30.07)
15. (0.02)

© Copyright: Subject matter to MADE EASY Publications, New Delhi: No part of this book may be reproduced or utilised in any form without the written permission.

### LEVEL 2 Objective Questions

16. (a)
17. (25.045)
18. (0.083)
19. (3.9)
20. (20.19)
21. (c)
22. (b)
23. (d)
24. (b)
25. (a)
26. (a)
27. (1.732)
28. (b)
29. (1.036)
30. (a)

■■■■



**LEVEL 3** Conventional Questions

**Solution : 31**

(i) Hole basis system

Hole	→	max. size = 30.012 mm
		min. size = 30.00 mm
Shaft	→	max. size = 29.98 mm
		min. size = 29.972 mm

(ii) Shaft basis system

Hole	→	max. size = 30.032 mm
		min. size = 30.02 mm
Shaft	→	max. size = 30 mm
		min. size = 29.992 mm

**Solution : 32**

**For Hole:**

Lower limit = 25 mm  
Upper limit =  $25 + 0.032685 = 25.032685$  mm

**For Shaft:**

Upper limit = 24.9361 mm  
Lower limit = 24.88383 mm

**Solution : 33**

Hole tolerance = 0.05 mm  
Shaft tolerance = 0.04 mm  
Allowance = 0.02 mm

**Solution : 34**

(i) Maximum clearance = 0.09 mm  
Minimum clearance = 0.04 mm

(ii) Allowance = Minimum clearance = 0.04 mm

(iii) Hole tolerances = 0.02 mm  
Shaft tolerances = 0.03 mm

(iv) Fundamental deviation of shaft = 0.04 mm

(v) Maximum material limit for hole = 30 mm  
Maximum material limit for shaft = 29.96 mm

(vi) Clearance fit

**Solution : 35**

Lower limit of size = 100.036 mm  
Tolerance = 0.0543 mm  
∴ Higher limit of size = 100.0903 mm

Minimum allowance = 0.036 mm  
 Maximum allowance = 0.2294 mm

**Solution : 36**

- (i) **Lay:** Lay or directionality, is the direction of the predominant surface pattern and is usually visible to the naked eye.
- (ii) **Cut off length:** The distance that the stylus travels in surface profilometers instruments is called cut-off length. It generally ranges from 0.08 mm to 25 mm.
- (iii) **RMS Value:** RMS (Root Mean Square) value is defined as

$$R_q = \sqrt{\frac{a^2 + b^2 + c^2 + d^2 + \dots}{n}}$$

Where  $a, b, c, d, \dots$  are absolute values and  $n$  is the number of readings.

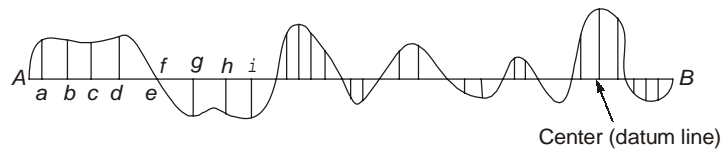

- (iv) **Roughness:** It is defined as closely spaced, irregular deviations on a scale smaller than that of waviness. Roughness is expressed in terms of its height, its width and its distance on the surface along which it is measured.
- (v) **CLA:** CLA or arithmetic mean value ( $R_a$ ) is based on the schematic illustration of the rough surface. The

$R_a$  value is defined as,  $\left( R_a = \frac{a + b + c + d + \dots}{n} \right)$



# 7

## CAD/CAM, Jigs & Fixtures

### LEVEL 1 Objective Questions

1. (b)
2. (b)
3. (a)
4. (a)
5. (a)
6. (b)
7. (0.022)
8. (c)
9. (d)
10. (b)
11. (3)

© Copyright: Subject matter to MADE EASY Publications, New Delhi: No part of this book may be reproduced or utilised in any form without the written permission.

### LEVEL 2 Objective Questions

12. (b)
13. (16.67)
14. (b)
15. (a)
16. (a)
17. (d)
18. (a)

■■■■

**LEVEL 3** Conventional Questions
**Solution : 19**

- (i) Linear velocity of table = 54.167 mm/sec  
 (ii) The BLU of NC system = 1 BLU  
 (iii) Frequency (f) = 5416.67 pps

**Solution : 20**

- (ii) In the line standards the unit of length is defined as the distance between the centres of engaged lines as in a steel rule. This form of measurement is not very convenient to use. When the length being measured is expressed as the distance between two surfaces, this is referred to as end standard. For all important works in the shop uses prefer end standards.
- (ii) Tolerance is the limit of random (unintentional) deviations of a dimension from its nominal value. Allowance is the amount of designed (intentional) deviation between two mating dimensions in a fit, which in combination with their respective tolerances, results into a maximum and minimum clearance or interference.

**Solution : 21**

(a) In point to point system, each axis of the machine is driven separately by lead screws and depending on the type of operation, at different velocities. The machine moves initially at maximum velocity in order to reduce non productive time but decelerates as the tool approaches its numerically defined position. Thus, in an operation such as drilling, the positioning and cutting takes place sequentially. Point to point systems are used mainly in drilling, punching and straight milling operations.

(b) In contouring system, the positioning and the operations are both performed along controlled paths but at different velocities. Because the tool cuts as it travels along a prescribed path, accurate control and synchronization of velocities and movements are important. This system is typically used in lathes, milling machines, grinders and machining centers.

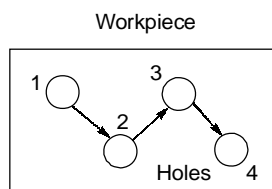
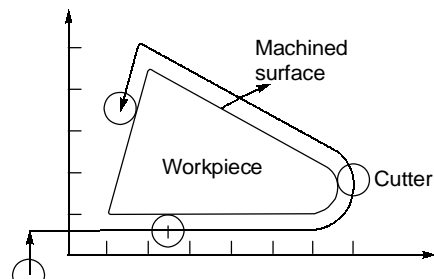
**Point-to-point System****Contouring (continuous path) control in NC**

- (ii) Given: Pitch = 3 mm, Control resolution = 0.01 mm,  
Pulse rate = 200/s

$$\text{Number of pulses/revolution} = \frac{3}{0.01} = 300 \text{ pulses/rev.}$$

As 1 revolution = 300 steps

$$\text{Size of step angle} = \frac{360}{300} = 1.2^\circ/\text{step}$$

$$\text{Revolutions per minute} = \frac{200}{300} \times 60 = 40 \text{ rpm}$$

$$\text{Linear travel rate} = 120 \text{ mm/min}$$

**Solution : 22**

**Jig:** is described as a plate, or metal box, structure or a device usually made of steel on to or into which components can be clamped or fastened or located and held in positive manner in identical position one after the other for specific operation in such a way that it will guide one or more cutting tools to be same position or any number of similar components which may be used upon it.

**Fixture:** is described as a structure for locating, holding and supporting a component or work piece securely in a definite position for a specific operation but it does not guide the cutting tool.

**Types of Jigs:**

- (i) **Template jigs:** are the simplest type used more for accuracy than speed. This type of jig fits over, on, or into the work and is not usually clamped, (Refer below Fig). If bushings are not used, then the whole jig plate is normally hardened.

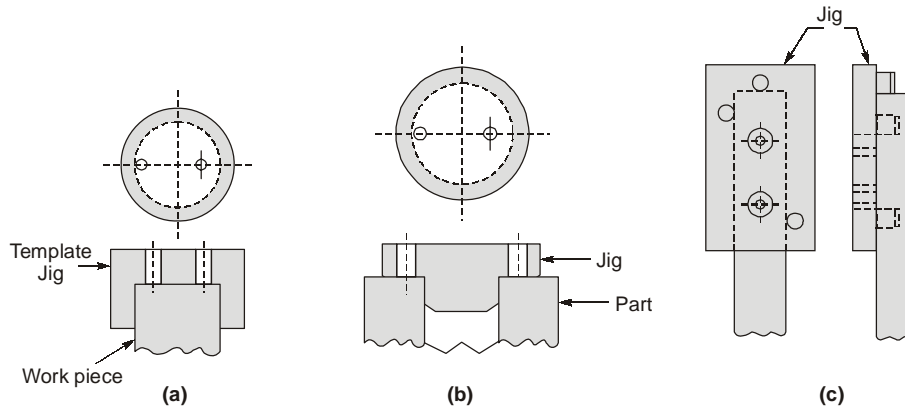

**Template Jigs**

- (ii) **Plate jigs:** are similar to templates excepting that these have built-in clamps to hold the work, shown in the figure below:

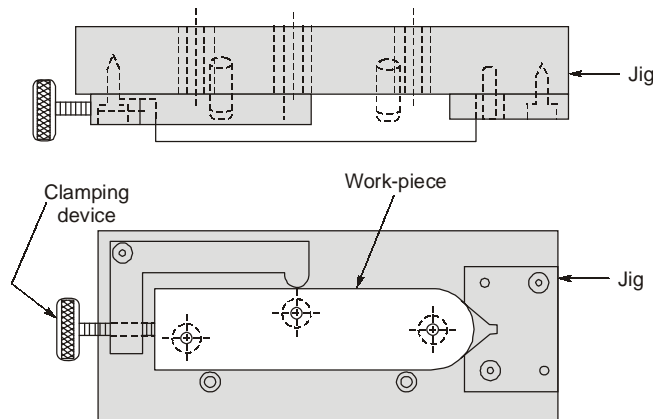

**Modified angle Plate Jig**

- (iii) **Angle-plate jigs:** These are used to hold parts which are to be drilled at right angles or some other angles to their mounting locators.
- (iv) **Indexing jigs:** These are used to accurately space holes or other machined areas around a part. Indexing is achieved by using a reference plate and a plunger.

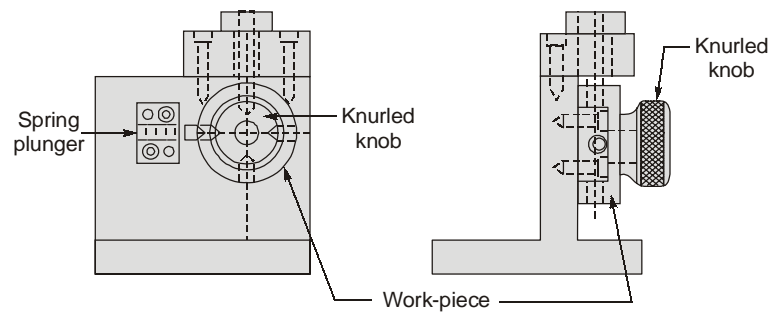

Indexing Jig

- (v) **Leaf jig** : These are small box type jigs with a hinged leaf to permit easy loading and unloading of part. Normally, these do not completely surround the part.

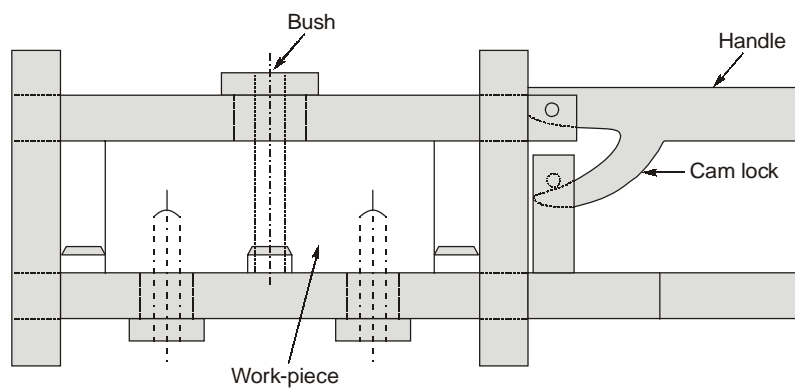

Leaf Jig

#### Types of Fixture:

- (i) **Plate fixture**: It is the simplest form of popular fixture due to its adaptability. The basic fixture is made from a flat plate which has a variety of clamps and locators to hold and locate the part. It is useful for most machining operations.

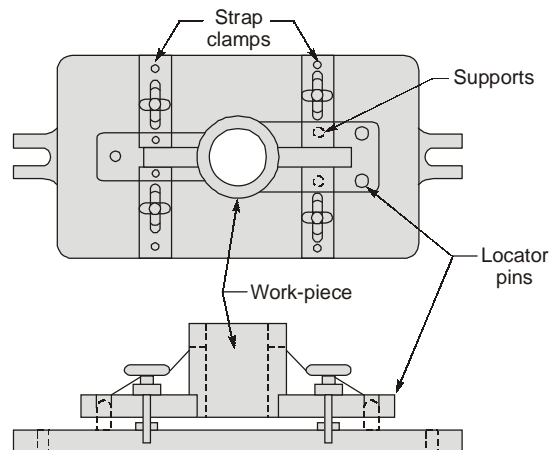
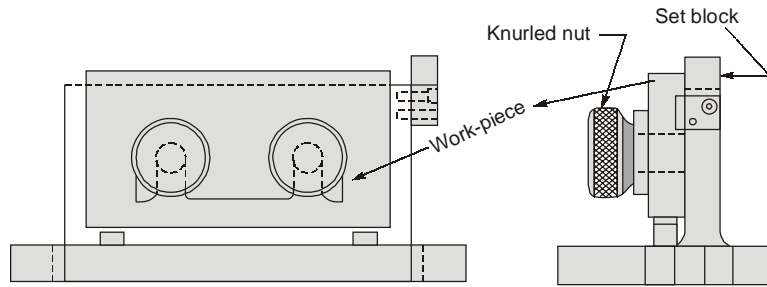

Plate fixture

- (ii) **Angle plate fixture:** This is used when the part is to be machined at right angle to its locator. Angle-plate fixtures are normally made at 90 degrees, but other angles are also possible.



**Angle-Plate fixture**

- (iii) **Vise-jaw fixture:** It is used for machining small parts. The standard vise jaws are replaced with jaws conforming to the shape of the part to be fitted. Their use is limited only by the sizes of the vises available.
- (iv) **Indexing fixture:** It is used for machining parts having evenly spaced machined surfaces.

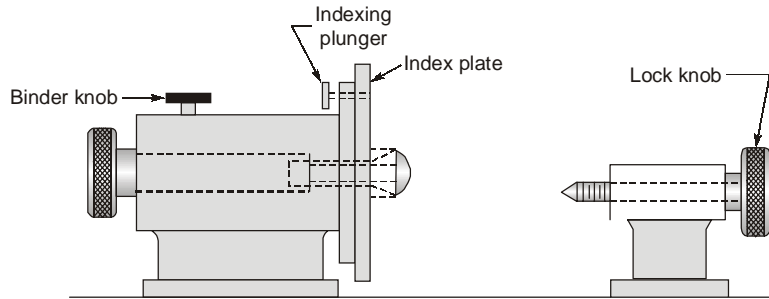

**Indexing fixture**

- (v) **Multistation fixture :** It is used for high-speed high volume-production runs in which the machining cycle is continuous. This form of fixture allows the loading and unloading operations to be performed while the machining operations are in progress at different stations.

**Solution : 23**

**Surface texture:** Its a repetitive or the nominal surface forming a pattern on the surface. It includes roughness, waviness, lays and flaws.

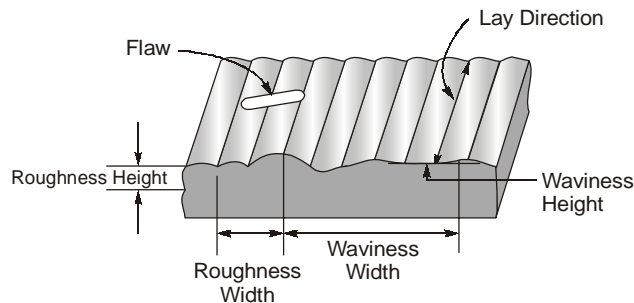

**Solution : 24**

**Numerical Control:** It is defined as a method of automation in which various functions of machine tools are controlled by letters, numbers and symbol.

**Computer Numerical Control:** It is an *NC* system, that utilizes a dedicated, stored program computer to perform some or all of the basic numerical control functions.

**Direct Numerical Control:** It is defined as a manufacturing system in which a number of machines are controlled by a computer (central mainframe computer) through direct connections and in real time.

**Developments and Improvements in their applications:**

- In *NC*, numbers form a program of instructions designed for a particular work part or job. When the job changes, the program of instructions is changed. This capability to change the program for each new job is what gives *NC* its flexibility.
- The program of instructions is the detailed step-by-step set of directions which tell the machine tool what to do. The most common input medium is 1-inch wide punched tape. Out of two methods, the first method of input to the *NC* system is called manual data input, and is appropriate only for relatively simple jobs. The second method of input is by means of a direct link with a computer. In computer assisted part programming much of the tedious computational work required in manual part programming is transferred to the computer. This is appropriate for complex work piece geometries and jobs with many machining steps. The use of computers provided significant improvements in part programming procedures. The control of *NC* machinery has also been dramatically enhanced through computer technology.
- **Computer numerical control (CNC)** uses the part program tape and tape reader only once to enter the program into computer memory. This results in improved reliability since the tape reader is commonly considered the least reliable component of a conventional *NC*. The *NC* tape can be corrected and even optimized. One of the most significant advantages of *CNC* over conventional *NC* is its flexibility, which provides the opportunity to introduce new control options with relative ease at low cost.
- In *DNC*, the punched tapes and tape readers are eliminated. In some *DNC* systems, the hard wired control unit is also eliminated and replaced by a special machine control unit designed to be more compatible with *DNC* operation. Because the computational and data processing function are implemented with software rather than with hard wired devices, there exists the flexibility to alter and improve the method by which these functions are carried out. Examples of their functions include circular interpolation and part programming packages with convenient editing and diagnostic features. The combination of *CNC* and *DNC* provides the opportunity to add new capability and refine existing capabilities in the computerised manufacturing systems.

**Solution : 25**

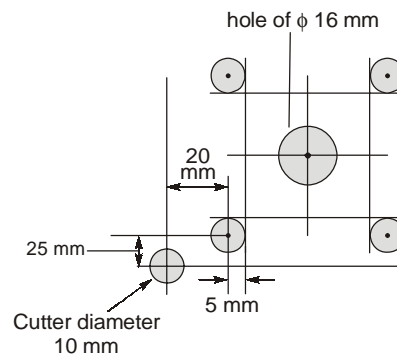

N01G92XOYOZO

N02 G90

N03 G01 G79X20000X25000 Z 20000 R11000 F100 T01 M03

N04 G79X230000 F100 S712

N05 G79X135000 F100 S712



- N06 G79X20000 F100 S712
- N07 G79X25000 F100 S712
- N08 G81X125000 Y80000 Z20000 R11000 F100 T02 M03
- N09 G85X125000 Y 80000 Z20000 R11000 F100 T03 M03.

**Solution : 26**

Pulse rate = 256 Hz

**Solution : 27**

**Open loop System:** In the open-loop system, the signals are sent to the servomotor by the controller, but the movement and final positions of the work table are not checked for accuracy.

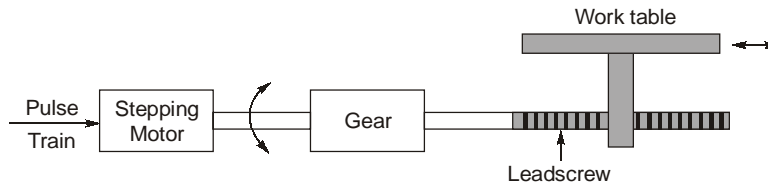

**Open Loop System**

**Closed loop System:** The closed loop system is equipped with various transducers, sensors and counters that measure accurately the position of the work table. Through feedback control, the position of the worktable is compared against the signal. This system is more complicated and more expensive than the open-loop system.

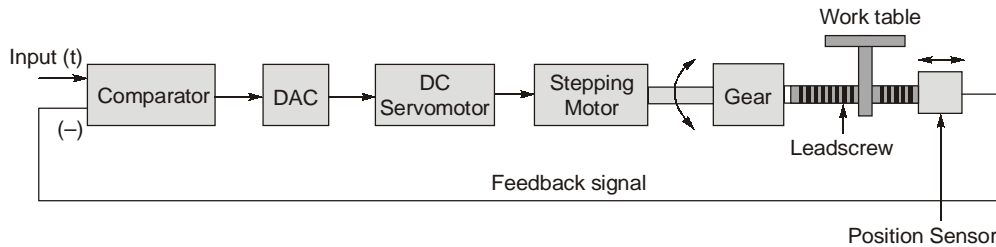

A physical interpretation of time constant for a first order linear control system may be found from the initial condition response of any output variable. If  $\tau$ (time constant)  $> 0$ , the response of any system variable is an exponential decay from the initial value toward zero, and the system is stable. If  $\tau$ (time constant)  $< 0$ , the response grows exponentially and the system is unstable. Thus, the time constant  $\tau$  which has units of time, is the system parameter that establishes the time scale of system response in a first order system. The response of first order system can be expressed as

$$\left( \frac{y(t)}{y(0)} \right) = e^{-(t/\tau)}$$

**Solution : 28**

- (i) Linear velocity of the table = 66.67 mm/sec. or 4 m/min
- (ii) The BLU of system = 0.01 mm
- (ii) 1 pulse = 1 BLU
- Frequency (f) = 6666.67 PPS



# 8

## Machine Tools

### LEVEL 1 Objective Questions

1. (d)
2. (a)
3. (1.3895) (1.32 to 1.45)
4. (51)(50 to 52)
5. (d)
6. (c)
7. (5183.63) (5180 to 5186)
8. (d)
9. (c)
10. (69)
11. (b)
12. (a)
13. (a)
14. (b)
15. (a)

© Copyright: Subject matter to MADE EASY Publications, New Delhi: No part of this book may be reproduced or utilised in any form without the written permission.

### LEVEL 2 Objective Questions

16. (199.99)
17. (a)
18. (d)
19. (b)
20. (65.625) (64 to 67)
21. (a)
22. (0.667) (0.5 to 0.7)
23. (c)
24. (94.280)
25. (261.799)
26. (b)
27. (b)
28. (20.94)
29. (0)
30. (d)
31. (c)

■■■■

**LEVEL 3** Conventional Questions

**Solution : 32**

$$T_3 = 8.89 \text{ min.}$$

**Solution : 33**

$$N = 36.66 \text{ rpm.}$$

**Solution : 34**

Optimum speed,  $V$  for minimum cost = 31.435 m/min.

Optimum cutting speed,  $V$  for maximum production = 36.5 m/min.

**Solution : 35**

time of machining 100 jobs = 103.5 minutes

**Solution : 36**

$$T_1 = 4 \text{ minutes}$$

$$T_2 = 25 \text{ minutes}$$

$$\text{Number of holes} = 397.7145 = 397 \text{ holes}$$

**Solution : 37**

$$n = 4 \text{ strokes}$$

**Solution : 38**

$$T = 0.75 \text{ min}$$

**Solution : 39**

$$t_{1 \max} = 0.0121 \text{ mm}$$

$$(f_s)_{\max} = 742.938 \text{ N}$$

$$(f_c)_{\max} = 952.234 \text{ N}$$

$$\theta = 24^\circ$$

$$\text{Power consumption} = 481.292 \text{ W}$$

**Solution : 40**

$$L = 25.7735 \text{ mm}$$

$$t = 0.644 \text{ min or } 38.66 \text{ second.}$$



# 9

## Powder Metallurgy & Grinding

### LEVEL 1 Objective Questions

1. (c)
2. (c)
3. (d)
4. (c)
5. (b)
6. (c)
7. (d)
8. (b)
9. (b)
10. (b)
11. (b)
12. (a)
13. (c)
14. (c)

© Copyright: Subject matter to MADE EASY Publications, New Delhi. No part of this book may be reproduced or utilised in any form without the written permission.

### LEVEL 2 Objective Questions

15. (c)
16. (a)
17. (a)
18. (c)
19. (a)
20. (b)
21. (16.69)
22. (c)
23. (b)
24. (c)
25. (b)

■■■■

**LEVEL 3** Conventional Questions

**Solution : 26**

**Centreless grinders:** In internal centreless grinding, the work is supported by three rolls. One is the regulating rolls, and the other is a pressure roll to hold the workpiece firmly against the support and regulating rolls. This is illustrated in fig. The grinding wheel contacts the inside diameter of the workpiece directly opposite the regulating roll, thus assuring a part of absolutely uniform thickness and concentricity. The pressure roll is mounted to swing aside to permit loading and unloading.

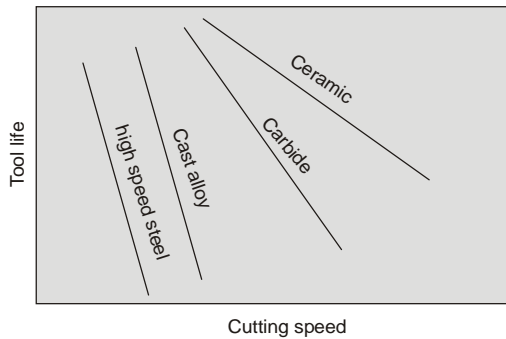
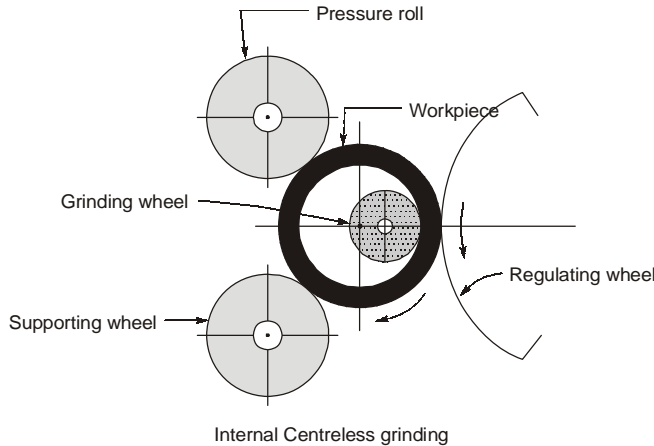

**Tool Life Curves:**

**Solution : 27**

(i) **Roll grinding:** Roll grinding is similar to cylindrical grinding with the exception that the grinders used in roll grinding are much heavier, more rigid and so is the more load carrying capacity than the grinders in cylindrical grinding.

The grinding wheel is located in a way similar to the tool post with an independent power, and is driven at high speed suitable for grinding operation. Both the work and grinding wheel rotate counter clockwise. The work that is normally held between centres is rotated at much lower speed compared to that of the grinding wheel. If the finished section to be ground is wider than the wheel, the wheel is fed in the transverse direction. Work pieces are normally mounted between centres and are driven by a dog.

Roll grinding is used for grinding "rolls" used in rolling mills.

(ii) **Thread grinding:** Internal or external threads can be finish ground by means of a single or multiple edge grinding wheel.

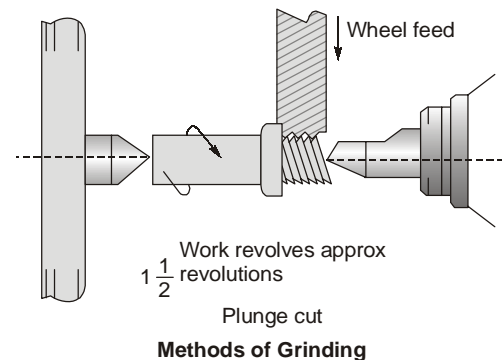
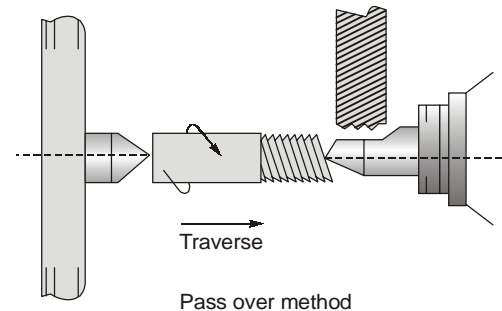

**Methods of Grinding**

The threads are cut as grinding wheel having annular thread grooves formed around (periphery) and work rotate. The process is carried on a special grinding machine having a master lead screw and gears and means of holding the work. The wheel rotates at 30 m/sec and work is rotated slowly. In the case of hardening stock probably grinding is the only means of forming threads. The accuracy of grinding exceeds that of any other method and the finish is exceeded only by good thread rolling. Pitch diameter can be ground to an accuracy of  $\pm 0.002$  mm per 25 mm and accuracy of lead may be maintained within 0.007 mm in 500 mm of thread length. Grinding eliminates tiny cracks due to hardening and also tearing is always present to some extent in any material removal method. Distortions due to heat treatment may be eliminated by grinding. Parts which would be distorted by milling threads can be satisfactorily ground. The thread parts which demand high accuracies and freedom from distortion, and stress cracks are usually made by this method.

**Two variations of process are:**

- (i) Pass over or traverse method and
- (ii) Plunge method.

In first method the wheel is positioned at full thread depth and then the work is traversed past the wheel. The work table traverse is controlled by a master leadscrew and change gears are used to suit the thread pitch. The first thread form on the wheel gets worn out fast since it removes maximum metal, and remaining threads effecting the finish. In the case of plunge cut thread grinding, the wheel is plunged into work to full thread depth. The workpiece then makes one revolution and work traverses one pitch.

**Speed:** In grinding work, speed indicates the number of metres measured in the circumference of the grinding wheel, that passed the surface of the job.

**Feed:** It is the amount of wheel (grinding) advancement per revolution of its own parallel to the surface being machined.

**Depth of cut:** It is the advancement of grinding wheel in the job in a direction perpendicular to the surface being machined.

**Solution : 28**

In metal injection molding, also called injection molding, very fine metal powders ( $< 10 \mu\text{m}$ ) are blended with either a polymer or a wax-based binder. The mixture then undergoes a process similar to die casting. The molded greens are placed in a low-temperature oven, to burn off the plastic or else the binder is removed by solvent extraction, then they are sintered in a furnace.

Metal suitable for metal-injection molding are carbon and stainless steels, tool steels, copper, bronze and titanium. Typical parts made are components for watches, small-caliber gun barrels, heat sinks, automobiles and surgical knives.

The following are the major advantages of metal injection molding over conventional compaction:

1. Complex shapes, having wall thicknesses as small as 5 mm, can be molded and then easily removed from the dies.
2. Mechanical properties are nearly equal to three of wrought products.
3. Dimensional tolerances are good.
4. High production rates can be achieved by the use of multi-cavity dies.

**Applications of Powder Metallurgy**

1. Oil-impregnated bearing made from either iron or copper alloys for home appliance and automotive applications.
2. Powder metallurgy filters can be made with pores of almost any size.
3. Pressure or flow regulators.

4. Small gears, cams etc.
5. Products where the combined properties of two or more metals (or both metals and nonmetals) are desired.
6. Cemented carbide are produced by the cold compaction of tungsten carbide powder in a binder, such as cobalt (5 to 12%), followed by liquid phase sintering.

**Solution : 29**

**Sequence of Processes in powder metallurgy**

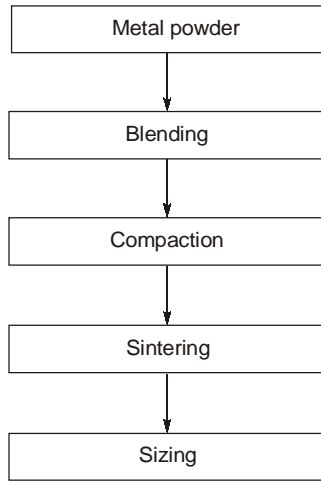

**Methods of Making Metal Powders :**

- **Metal Crushing and pulverizing** : Brittle materials can be converted into powder by crushing. If the material is not sufficiently brittle, its temperature is decreased.
- **Atomization** : Ductile materials or the materials having low melting point, can be converted into powder by this method. Liquified material is poured over a high speed rotating disk. Due to the centrifugal action, liquid metal comes down in the form of very fine droplets. The material can also be sprayed by using a plasma torch.
- **Corrosion** : When stainless steel is kept in the environment of sulphuric acid and copper sulphate, it dissolves and settles down at the bottom of tank. But this method takes time.

**Blending** : By mixing the lubricant with powders, a layer of lubricant will be deposited over the particles. This will increase the interaction between them and as a result of that powder can be given some shape called green compact. This is called as green because it is freshly prepared.

**Compaction** : It is also called as Iso-static pressing. To give initial strength to the green compact, powder is pressed on a press. Variation in the properties of compact will be more when the compaction is done on a single or a double action press. But on a double action press, properties will be more uniform. Smaller is the size of particle, better will be under diffusion and the compact will be stronger. If the particle size is smaller, the strength will be better because more area will be under diffusion.

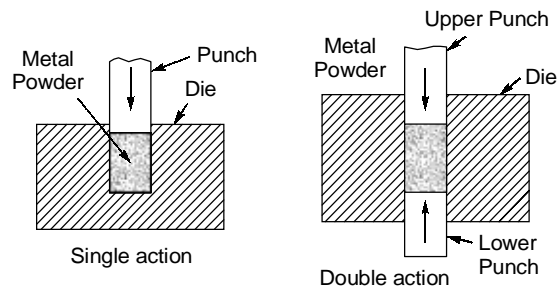

- (a) **Pre-sintering** : When heating is done along with compaction it is called Hot Iso-static pressing (HIP). Compact is heated and due to that lubricant on the surface of particle will burn. Characteristic of lubricant should be such that after burning, it should not leave any residue. This provides the localized heating which increases the extent of diffusion between the particles. When Pre-sintering is clubbed compaction, it is called Hot Iso-static pressing. Rough particles give better strength as interlocking among the particles is better.
- (b) **Sintering** : In the sintering stage, compact is heated to 60-70% of the melting point of the base metal. This increases the extent of diffusion between the particles. Those powder which could not form interlocking and whose melting point are below this temperature, they will be liquified and will fill up the voids. When the compact is a mixture of large number of powders having large difference in their melting point two or three stage melting process is performed. After sintering, product appears to be very hard and brittle, so normally no machining is advisable but to give some simple shapes to the part sizing is performed. Powder metallurgy can only be applied for mass production because of expensive tooling arrangement.

