

ESE

GATE

State Engg. Exams

MADE EASY
WORKBOOK 2027



**Detailed Explanations of
Try Yourself *Questions***

Electronics Engineering
Analog Circuits



2

Diode Circuits-II



Detailed Explanation of Try Yourself Questions

T1. (a)

In this question we need to determine which diode is on and which diode is OFF, clearly diode D_3 is OFF because if it is on then current from current source will flow from n to p terminal of the diode D_3 and this is not possible, hence D_3 is OFF. Applying the same concept, we can say diode D_2 is also OFF. Diode D_1 is on because it is forced by the battery of 10 V.

T2. (c)

Assume D_1 on, D_2 off, D_3 on

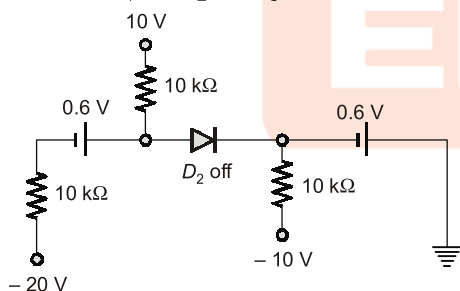

$$I_{D1} = \frac{10 - 0.6 - (-20)}{20k} = 1.47 \text{ mA}$$

$$I_{D2} = 0 ; I_{D3} = \frac{0 - 0.6 - (-10)}{10k} = 0.94 \text{ mA}$$

T3. (c)

Since all the voltage are positive all the diodes will try to be forward biased but only the diode with highest voltage will be switched on rest will be in off state.

T4. (b)

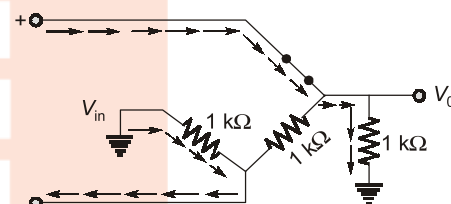

For positive cycle of input

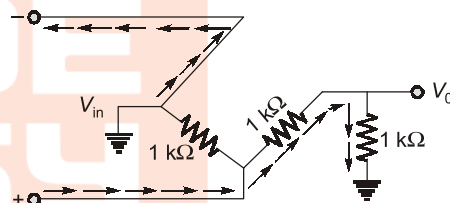

For negative cycle of input

thus the V_{in} will appear across the series combination of the two $1 \text{ k}\Omega$ resistors and we are taking output across $1 \text{ k}\Omega$ resistance only hence the output will be reduced by 50 % and the above circuit will work as a full wave rectifier with an attenuation of 1/2.

T5. (b)

Since there is a D.C level shift in the output waveform thus the circuit must be a clamper circuit and when the diode is conducting then the voltage at the output must be 5 V as seen from the output waveform hence option (b).

T6. (a)

T7. (c)

If $V_{in} < 1.7\text{ V}$: D_2 -OFF, D_1 -OFF

$$V_{out} = V_{in}$$

Minimum, $V_{out} = -5\text{ V}$

If $V_{in} > 1.7\text{ V}$: D_2 -ON, D_1 -OFF

$$V_{out} = \frac{V_{in} \times 1 + 1.7 \times 1}{1 + 1} = \frac{V_{in} + 1.7}{2}$$

Maximum, $V_{out} = \frac{5 + 1.7}{2} = 3.35\text{ V}$

T8. (35.16)

If $V_i < 4.5\text{ V}$: D_1 -ON, D_2 -OFF

$$i_b = 0$$

If $V_i > 4.5\text{ V}$: D_1 -OFF, D_2 -ON

$$i_b = 100\text{ mA}$$

$$\theta = \sin^{-1} \frac{4.5}{10} = 26.7^\circ$$

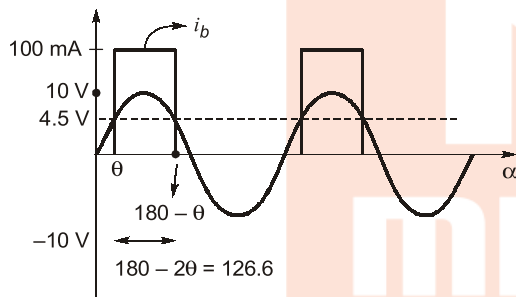

$$\text{Average value of } i_b = \frac{\text{Area}}{\text{Time period}}$$

$$= \frac{100\text{ mA} \times 126.6}{360} = 35.16\text{ mA}$$

T9. (b, c)

Assume all diode OFF.

$$V_{D1} = 10 - 5 = 5\text{ V}$$

$$V_{D2} = 10 - 0 = 10\text{ V}$$

$$V_{D3} = 5 - 10 = -5\text{ V}$$

V_{D2} is greater \Rightarrow Consider D_2 ON.

Assume D_1, D_3 OFF.

$$I_{D2} = \frac{10 - 0.6}{10\text{ k}\Omega} = 0.94\text{ mA}$$

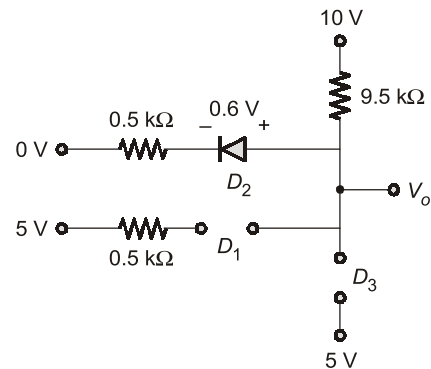

$$V_o = 10 - 9.5 \times 0.94$$

$$V_o = 1.07\text{ V}$$

Now,

$$V_{D1} = 1.07 - 5 = -3.93\text{ V}$$

$$V_{D3} = 5 - 1.07 = 3.93\text{ V}$$

$V_{D3} > V_{D1} \Rightarrow$ Consider D_3 ON

Assume D_1 OFF.

$$V_o = 5 - 0.6 = 4.4\text{ V}$$

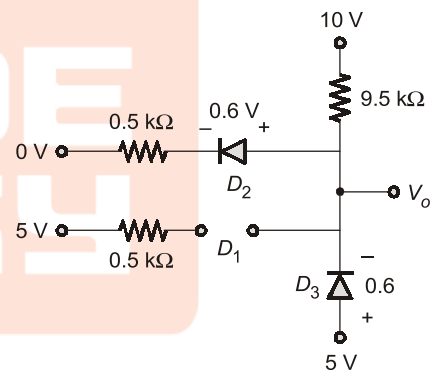

$$V_{D1} = 4.4 - 5 = -0.6\text{ V}$$

$\Rightarrow D_1$ is OFF.

$$I_{D2} = \frac{4.4 - 0.6}{0.5} = 7.6\text{ mA}$$

$$I_{D1} = 0$$



3

DC Analysis of BJT Circuits



Detailed Explanation of Try Yourself Questions

T1. (a)

$$V_{CC} - I_{C1}R_2 - V_{CE1} = 0$$

$$6 - 1.5 \text{ mA} \times R_2 - 3 = 0$$

$$R_2 = 2 \text{ k}\Omega$$

$$I_{B1} = \frac{I_{C1}}{\beta_1} = \frac{1.5 \text{ mA}}{150} = 0.01 \text{ mA}$$

I_{B2} will be equal to I_{B1} as there is no change in R_1

$$I_{C2} = \beta_2 I_{B2}$$

$$= 200 \times 0.01 \text{ mA} = 2 \text{ mA}$$

$$V_{CE2} = V_{CC} - I_{C2}R_2$$

$$= 6 - 2 \text{ mA} \times 2 \text{ k}\Omega = 2 \text{ V}$$

The new operating point is $Q(2 \text{ V}, 2 \text{ mA})$

$$I_1 = \frac{12}{6+4+2} \text{ mA}$$

$$I_1 = 1 \text{ mA}$$

Applying KVL in loop L

$$I_1 \times 2 \text{ k}\Omega - I \times 3 \text{ k}\Omega = V_{BE}$$

$$2 - I \times 3 \text{ k} = 0.5$$

$$-I \times 3 \text{ k} = -1.5$$

$$I = \frac{-1.5}{-3} \times 10^{-3} = 0.5 \text{ mA}$$

T3. (4.67)

If BJT is in saturation

$$I_B = \left(\frac{5 - 0.8}{200} \right) \times 10^{-3}$$

$$I_B = 2.1 \times 10^{-5}$$

$$I_B = 21 \mu\text{A}$$

$$I_{C \text{ sat}} = \frac{10 - 0.2}{R_C}$$

for saturation, $I_B \geq I_{B \text{ min}}$

$$I_B \geq \frac{I_{C \text{ sat}}}{\beta}$$

$$21 \times 10^{-6} \times 100 \geq \frac{9.8}{R_C}$$

$$R_C \geq \frac{9.8}{21 \times 10^{-4}}$$

$$R_C \geq \frac{98}{21} \text{ k}\Omega$$

$$(R_C)_{\text{min}} = 4.67 \text{ k}\Omega$$

T2. (0.5)

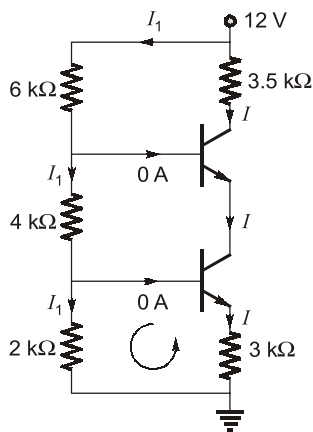

T4. (a)

$$I_{ref} = \frac{9 - 0.7}{30 \times 10^3} = 0.277 \text{ mA}$$

at node 'a' $I_{ref} = I_C + 3I_B$
(I_{B3} is assumed negligible)

$$= I_C \left(1 + \frac{3}{\beta} \right)$$

$$I_C = I_{ref} \left(\frac{\beta}{3 + \beta} \right)$$

$$= 0.277 \times 10^{-3} \left(\frac{125}{128} \right)$$

$$I_{C1} = 0.27 \text{ mA}$$

T5. (c)

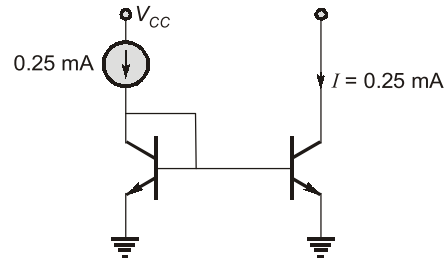

Using current mirror concept,
For large ' β ',

$$I = I_{ref}$$

so,

$$I_y = (0.25 + 0.25 + 0.25) \text{ mA}$$

$$I_x = (0.25 + 0.25) \text{ mA}$$

$$I_x + I_y = (0.25) 5 \text{ mA}$$

$$= 1.25 \text{ mA}$$

■■■■



4

Small Signal Analysis of BJT Amplifier



Detailed Explanation of Try Yourself Questions

T1. (d)

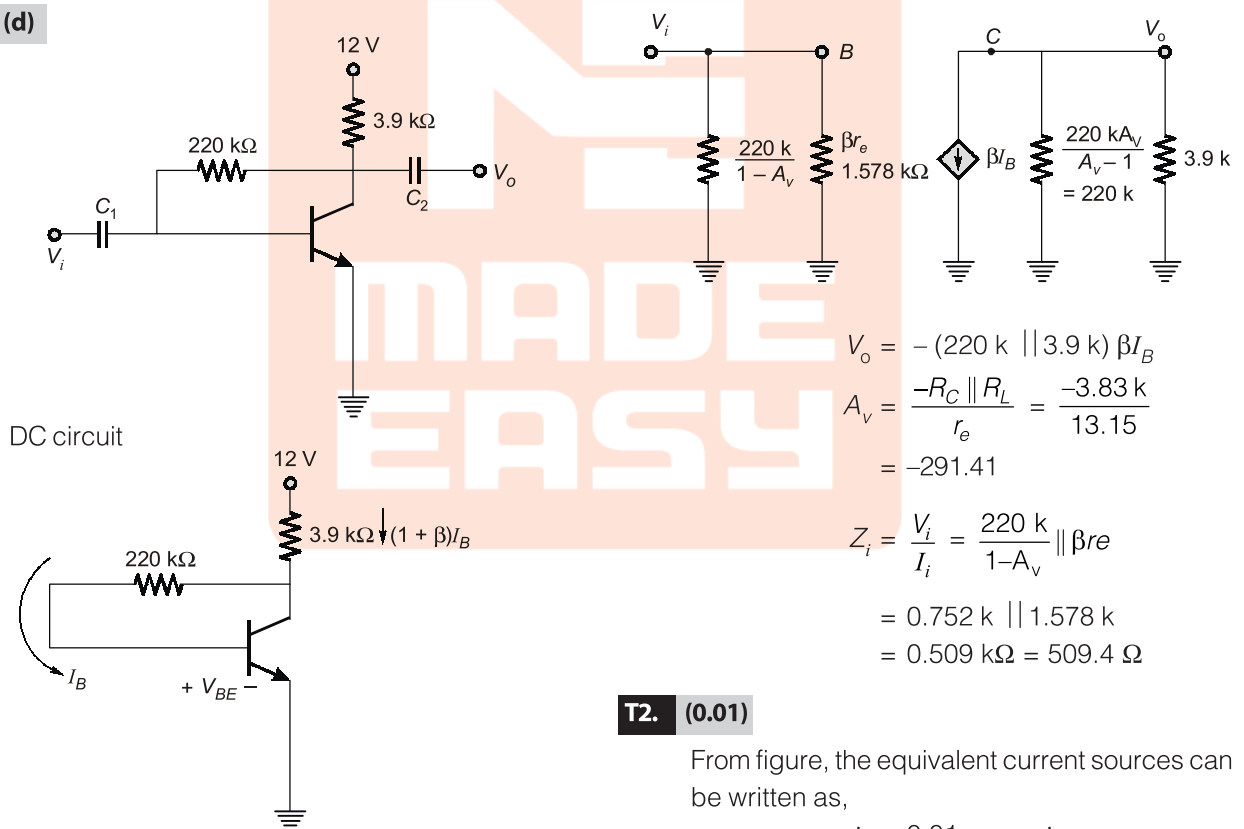

DC circuit

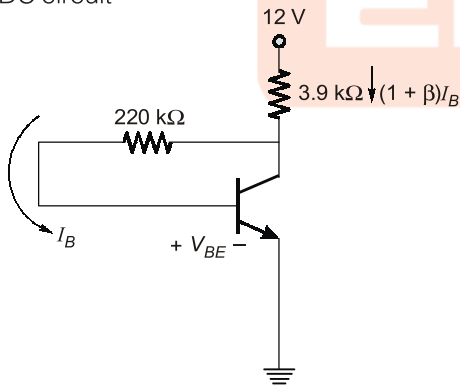

$$I_B = \frac{12 - 0.7}{(1 + \beta)3.9 \text{ k} + 220 \text{ k}}$$

$$= 0.0163 \text{ mA}$$

$$I_E = (1 + \beta)I_B = 1.97 \text{ mA}$$

$$r_e = \frac{V_T}{I_E} = \frac{26 \text{ mV}}{1.97 \text{ mA}} = 13.15 \Omega$$

$$V_o = -(220 \text{ k} \parallel 3.9 \text{ k}) \beta I_B$$

$$A_v = \frac{-R_C \parallel R_L}{r_e} = \frac{-3.83 \text{ k}}{13.15}$$

$$= -291.41$$

$$Z_i = \frac{V_i}{I_i} = \frac{220 \text{ k}}{1 - A_v} \parallel \beta r_e$$

$$= 0.752 \text{ k} \parallel 1.578 \text{ k}$$

$$= 0.509 \text{ k}\Omega = 509.4 \Omega$$

T2. (0.01)

From figure, the equivalent current sources can be written as,

$$i_c = 0.01 v_{be} = \alpha i_e$$

$$\Rightarrow i_e = \frac{v_{be}}{r_e}; \quad r_e = 98 \Omega$$

$$\text{So, } \alpha \left(\frac{v_{be}}{r_e} \right) = 0.01 v_{be}$$

$$\alpha = (0.01) \cdot r_e = 0.98$$

T3. (c)

We know $g_m r_\pi = \beta$

$$r_\pi = \frac{\beta}{g_m} = \frac{100}{10} \times 10^3 = 10 \text{ k}\Omega$$

Drawing the small signal equivalent, we get

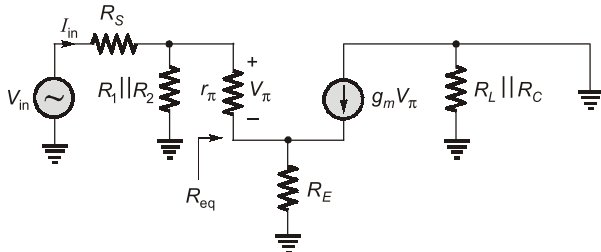

$$\therefore \frac{V_{in}}{I_{in}} = R_{in} = R_S + (R_1 \parallel R_2 \parallel R_{eq})$$

Now, to calculate R_{eq} , we can use another model

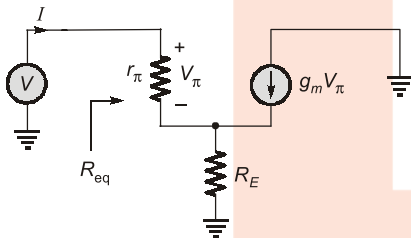

now,

\Rightarrow

$$V = I r_\pi + (I + g_m V_\pi) R_E$$

$$V_\pi = I r_\pi$$

$$V = I r_\pi + R_E I + g_m r_\pi R_E I$$

$$g_m r_\pi = \beta$$

\therefore

$$V = (r_\pi + (\beta + 1) R_E) I$$

$$R_{eq} = \frac{V}{I} = r_\pi + (\beta + 1) R_E$$

$$\therefore R_{in} = R_S + [R_1 \parallel R_2 \parallel (r_\pi + (\beta + 1) R_E)]$$

putting the values

$$R_{eq} = 10 \text{ k}\Omega + 101 \times 500$$

$$= 60.5 \text{ k}\Omega$$

\therefore

$$R_{in} = 1 \text{ k}\Omega + 4.62 \text{ k}\Omega$$

$$= 5.62 \text{ k}\Omega$$

T4. (c)

Drawing the small signal model of the above circuit, we get

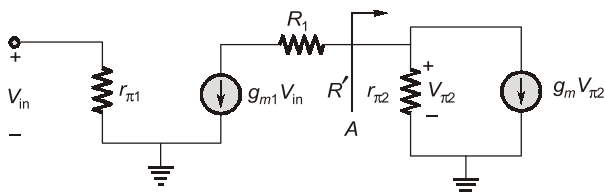

Let R' be the input resistance as seen in from point A.

Thus, to calculate R' we can draw the diagram separately

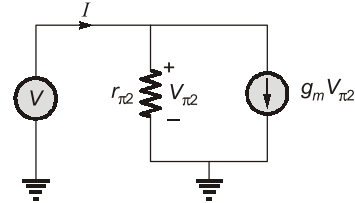

$$\therefore R' = \frac{V}{I} = \left(\frac{1}{g_{m2}} \parallel r_{\pi2} \right)$$

Thus, the value of the output voltage

$$V_o = -g_{m1} V_{in} (R_1 + R')$$

$$\frac{V_o}{V_{in}} = -g_{m1} \left(R_1 + \left(\frac{1}{g_{m2}} \parallel r_{\pi2} \right) \right)$$

T5. (b)

Drawing the small signal equivalent model of the circuit, we get

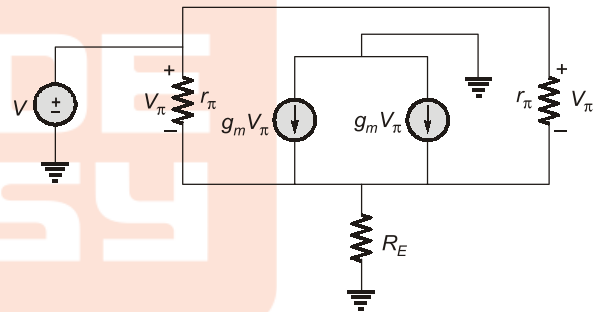

Thus, the equivalent circuit can be drawn as

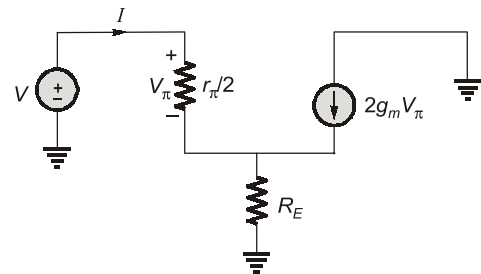

now,

$$I = \frac{V_\pi}{r_\pi / 2} = \frac{2V_\pi}{r_\pi} \quad \dots(i)$$

and

$$V_{in} = V_\pi + (I + 2g_m V_\pi) R_E$$

$$= V_\pi + \frac{R_E (2V_\pi)}{r_\pi} + 2g_m R_E V_\pi$$

$$= \left(1 + \frac{2R_E}{r_\pi} + 2g_m R_E \right) V_\pi$$

$$V_{in} = (r_\pi + 2R_E + 2g_m r_\pi R_E) \frac{V_\pi}{r_\pi}$$

$$V_{in} = (r_\pi + 2(1 + \beta)R_E) \frac{V_\pi}{r_\pi}$$

($\because g_m r_\pi = \beta$)

$$\therefore V_\pi = \frac{V_{in} r_\pi}{(r_\pi + 2(1 + \beta)R_E)} \quad \dots(ii)$$

now, substituting equation (ii) in (i), we get

$$I = \frac{2V_{in}}{(r_\pi + 2(1 + \beta)R_E)}$$

$$\therefore R_{in} = \frac{V_{in}}{I} = \frac{r_\pi + 2(1 + \beta)R_E}{2}$$

■■■■



5

DC Analysis of MOSFET Circuits



Detailed Explanation of Try Yourself Questions

T1. (a)

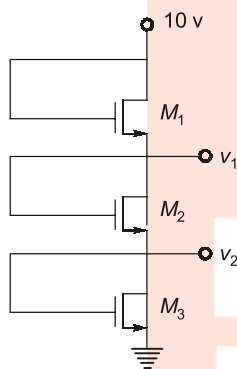

As $V_D = V_G \therefore$ we conclude that each MOSFET is in saturation.

$$I_D = k_{n1} (V_{GS} - V_T)^2$$

MOSFET M_1

$$I_D = k_{n1} (V_{GS1} - V_T)^2$$

$$V_{GS1} = 10 - 5 = 5 \text{ v}$$

$$0.5 \text{ mA} = 36\mu \times \frac{1}{2} \cdot \left(\frac{W}{L}\right) \times (5 - 1)^2$$

$$\left(\frac{W}{L}\right)_1 = 1.73$$

MOSFET M_2

$$I_D = k_{n2} (V_{GS2} - V_T)^2$$

$$0.5 \text{ mA} = 36\mu \times \frac{1}{2} \left(\frac{W}{L}\right)_2 (3 - 1)^2$$

$$\left(\frac{W}{L}\right)_2 = 6.94$$

MOSFET M_3

$$I_D = k_{n3} (V_{GS3} - V_T)^2$$

$$0.5 \text{ mA} = 36\mu \times \frac{1}{2} \left(\frac{W}{L}\right)_3 (2 - 1)^2$$

$$\left(\frac{W}{L}\right)_3 = 27.8$$

T2. (c)

If $V_{Th} = 0.4 \text{ v}$

PMOS in depletion mode

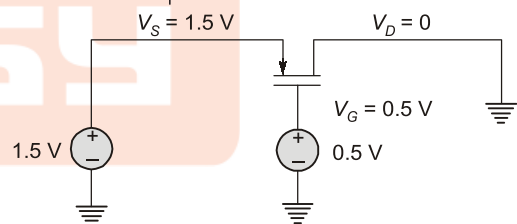

$V_{SD} > V_{SG} + V_{Th} \rightarrow$ current saturation

$V_{SD} < V_{SG} + V_{Th} \rightarrow$ Triode region

$$V_{SD} = V_S - V_G = 1.5 - 0.5 = 1 \text{ v}$$

$$V_{SD} = V_S - V_D = 1.5 - 0 = 1.5 \text{ v}$$

$1.5 > 1 \text{ V} + 0.4$ current saturation region

$$V_S = 0.9 \text{ v} \quad V_D = 0.9 \text{ v}$$

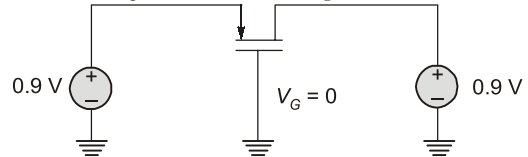

PMOS in depletion mode.

$$V_{SD} = V_S - V_D = 0.9 - 0.9 = 0$$

$$V_{SG} = V_S - V_G = 0.9 - 0 = 0.9$$

$$0 < 0.9 + 0.4 \text{ ; triode region}$$

T3. (a)

To calculate the value of V_{DS} , we require the voltage of both drain and source terminal.

Now, assuming the transistor to be in saturation region, the value of V_{GS} can be calculated as

$$I_D = \frac{\mu_n C_{ox} W}{2L} (V_{GS} - V_T)^2$$

$$1 \times 10^{-3} = 0.5 \times 10^{-3} \times (V_{GS} - V_T)^2$$

$$\sqrt{2} + 1.2 = V_{GS}$$

$$V_{GS} = 1.414 + 1.2$$

$$V_{GS} = 2.614 \text{ V}$$

Now, $V_{GS} = V_G - V_S$

$\therefore V_G = 0$

Thus $V_S = -2.614 \text{ V}$

And $V_D = 5 \text{ V}$

Thus, $V_{DS} = V_D - V_S = 5 - (-2.614)$

$$V_{DS} = 7.614 \text{ V}$$

$V_{DS} > V_{GS} - V_T$, so our assumption is correct.

T4. (d)

Since the configuration represents an inverter MOSFET with an active load, the output will be high for low values of input signal and low for high values of input signal.

Now, since the load transistor T_1 has shorted drain and gate,

$$V_{DS} > V_{GS} - V_T$$

$$0 > -V_T$$

Which is always true hence the transistor T_1 will always work in saturation region.

When $V_{in} = 0 \text{ V}$, $I_D = 0$.

Hence, $I_D = K_n (V_{GS1} - V_T)$

$$0 = (V_{GS1} - V_T)$$

$$V_{G1} - V_{S1} - V_T = 0$$

For transistor T_1 ,

$$V_{S1} = V_0 \text{ and } V_{GS1} = V_{DD} = 5 \text{ V}$$

Thus,

$$V_{G1} - V_0 - V_T = 0$$

$$5 - V_0 - 1 = 0$$

$$-V_0 = -4 \text{ V}$$

$$V_0 = 4 \text{ V}$$

Hence maximum value of output = 4 V.

■■■■

6

Small Signal Analysis of MOSFET Amplifier



Detailed Explanation of Try Yourself Questions

T1. (b)

By drawing the small signal equivalent circuit by deactivating all the D.C. supplies, we get,

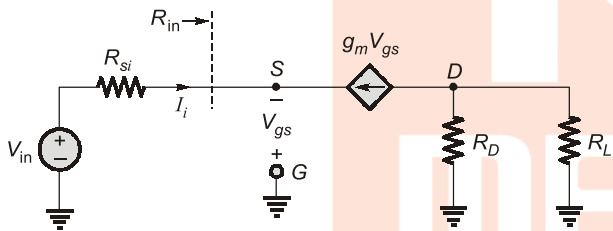

Now, from the figure,

$$R_{in} = \frac{-V_{gs}}{I_i}$$

and

$$I_i = -g_m V_{gs}$$

\therefore

$$R_{in} = \frac{-V_{gs}}{-g_m V_{gs}} = \frac{1}{g_m}$$

T2. (a)

By drawing the small signal equivalent circuit, we get

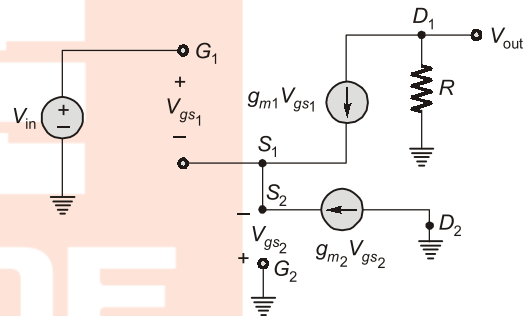

the above circuit can be redrawn as

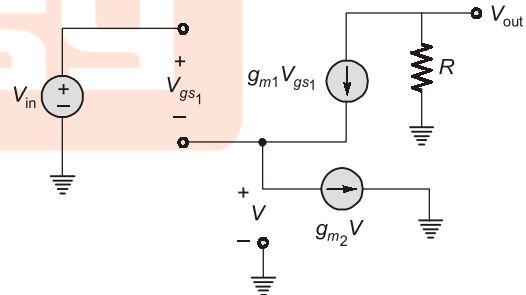

Substituting $V = -V_{gs2}$
now, $V_{in} = V_{gs1} + V$... (i)

and $g_{m1} V_{gs1} = g_{m2} \cdot V$
(\because from KCL at node S_1) ... (ii)

thus $V_{out} = -[g_{m1} V_{gs1} R]$... (iii)

$$V_{out} = -g_{m1} R (V_{in} - V) \quad (\text{from (i)})$$

$$= -g_{m1} R V_{in} + g_{m1} R V$$

now, $V = \frac{g_{m1} V_{gs1}}{g_{m2}}$ (from equation (ii))

$$V_{\text{out}} = -g_{m_1} R V_{\text{in}} + \frac{g_{m_1} R V_{gs_1}}{g_{m_2}} \cdot g_{m_1}$$

now from (3), we get

$$V_{\text{out}} = -g_{m_1} R V_{\text{in}} - \frac{g_{m_1}}{g_{m_2}} V_{\text{out}}$$

$$\left(1 + \frac{g_{m_1}}{g_{m_2}}\right) V_{\text{out}} = -g_{m_1} R V_{\text{in}}$$

$$V_{\text{out}} = \frac{-g_{m_1} R}{1 + \frac{g_{m_1}}{g_{m_2}}} V_{\text{in}}$$

$$\frac{V_{\text{out}}}{V_{\text{in}}} = \frac{-R}{\frac{1}{g_{m_1}} + \frac{1}{g_{m_2}}}$$

Hence, option (a) is correct.



7

Multistage Amplifiers



Detailed Explanation of Try Yourself Questions

T1. (b)

The input resistance will be

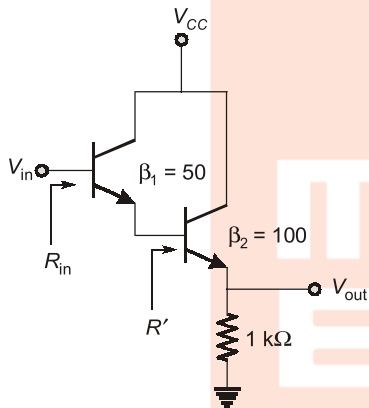

$$R' = r_{\pi} + (\beta_2 + 1)R_E$$

$$= 1\text{k} + (101)(1\text{k}) = 102\text{ k}\Omega$$

$$R_{in} = r_{\pi} + (\beta_1 + 1)R'$$

$$= 1\text{k} + (51)(102\text{k}) = 5.203\text{ M}\Omega$$

$$\frac{V_o}{A_{V_{o2}} \times V_2} = \frac{R_L}{R_L + R_{O2}} \quad \dots(i)$$

$$\text{where, } V_2 = \frac{A_{V_{o1}} \times V_{in} R_{in2}}{R_{in2} + R_{O1}} \quad (ii)$$

From equations (i) and (ii), we get

$$\frac{V_o}{V_{in}} = A_{V_{o2}} \times A_{V_{o1}} \times \frac{R_L}{R_L + R_{O2}} \times \frac{R_{in2}}{R_{in2} + R_{O1}}$$

$$\Rightarrow \frac{V_o}{V_{in}} =$$

$$5 \times 10 \times \frac{1\text{k}\Omega}{1\text{k}\Omega + 0.2\text{k}\Omega} \times \frac{5\text{k}\Omega}{5\text{k}\Omega + 1\text{k}\Omega}$$

$$\Rightarrow \frac{V_o}{V_{in}} = 34.72$$

T3. (b)

$$f_L = 20\text{ Hz}$$

$$f_H = 1\text{ kHz for single stage.}$$

For cascaded stage

$$f_L^* = \frac{f_L}{\sqrt{2^{1/n} - 1}} = \frac{20}{\sqrt{2^{1/3} - 1}} = 39.2\text{ Hz}$$

$$f_H^* = f_H \sqrt{2^{1/n} - 1} = 0.5\text{ kHz}$$



T2. (34.72)

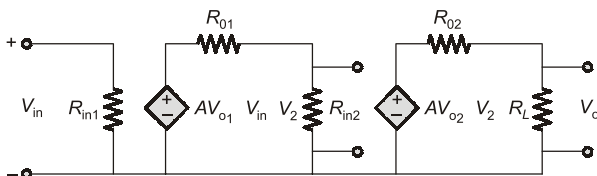

8

Negative Feedback Amplifiers



Detailed Explanation of Try Yourself Questions

T1. (a)

The overall forward gain is 1000 and close loop gain is 100. Thus, $\beta = 0.009$.

Now, when gain of each stage increase by 10% then overall forward gain will be 1331 and using the previous value of β the close loop will be 102.55.

⇒ Close loop Voltage gain increase by 2.55%.

T2. (b)

The feedback element is R_f , it samples voltage and mix current so shunt-shunt feedback.



10

Applications of OP-amps



Detailed Explanation of Try Yourself Questions

T1. (b)

Output of op-amp 1

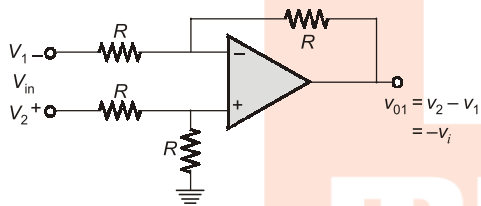

It is connected to schmitt trigger (inverting mode) → clockwise.
But inverting amplifier + inverting schmitt trigger → anticlockwise.

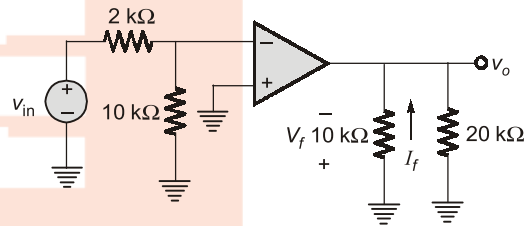
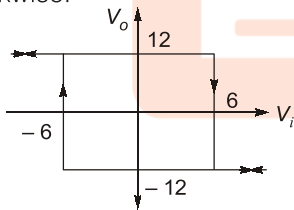

$$\beta = \frac{V_f}{V_o} = -1$$

$$\beta = \frac{I_f}{V_o} = -\frac{1}{10k}$$

$$|\beta| = \frac{1}{10k}$$

$$R_{if} = \frac{R_i}{A\beta} = \frac{10k}{10^5 \times \frac{1}{10k}}$$

$$= \frac{10 \times 10 \times 10^6}{10^5}$$

$$R_{if} = 1 \text{ k}\Omega$$

T2. (b)

$$R_{if} = \frac{R_i}{1 + A\beta} = \frac{R_i}{A\beta} \quad A\beta \gg 1$$

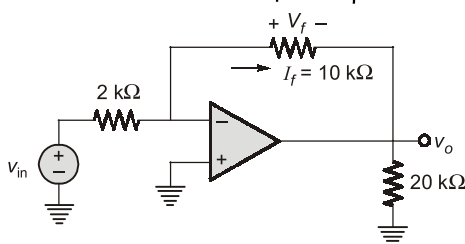

voltage shunt

T3. (b)

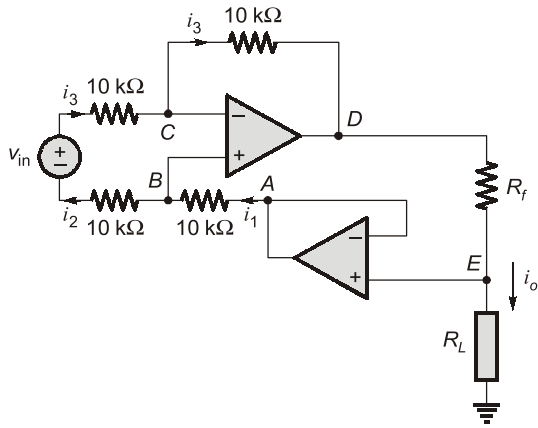

From the circuit,

$$V_E = i_o R_L$$

$$V_E = V_A \text{ (Virtual short concept)}$$

$$i_1 = i_2 = i_3$$

If we apply KVL between node B and C,

$$\therefore V_B = V_C \text{ (Virtual short concept)}$$

$$i_1 = i_2 = i_3 = \frac{V_{in}}{20 \text{ k}\Omega}$$

$$V_C - V_D = i_3 \times 10 \text{ k}\Omega = \frac{V_{in}}{2}$$

and $V_A - V_B = i_1 \times 10 \text{ k}\Omega = \frac{V_{in}}{2}$

$$\therefore V_B = V_C$$

$$\Rightarrow V_D - V_E = -V_{in}$$

$$\therefore i_o = \frac{-V_{in}}{R_f}$$

$$\bullet A_{of} = \frac{A_o}{1 + A_o\beta} \approx 80$$

$$\bullet f'_c = f_c(1 + A_o\beta) = 8 \left(1 + \frac{10^5}{80} \right) \text{ Hz} = 10,008 \text{ Hz}$$

• Gain at $f = 15 \text{ kHz} = 15000 \text{ Hz}$ is,

$$A_f = \frac{A_{of}}{\sqrt{1 + \left(\frac{f}{f'_c}\right)^2}} = \frac{80}{\sqrt{1 + \left(\frac{15000}{10008}\right)^2}} \approx 44.4$$

T5. (0.6)

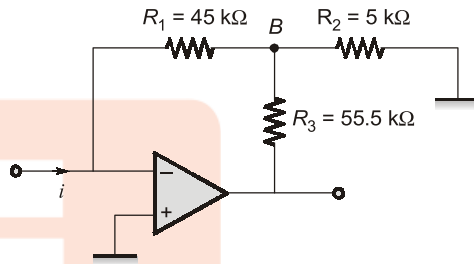

$$V_A = 0 \text{ (By virtual ground)}$$

$$\frac{V_B - 0}{45} + \frac{V_B - V_o}{55.5} + \frac{V_B - 0}{5} = 0$$

$$i = \frac{-(V_B - 0)}{45}$$

$$\therefore V_B = -45i$$

$$\frac{-45i}{45} + \frac{(-45i) - V_o}{55.5} + \frac{(-45i)}{5} = 0$$

$$-i - \frac{45i + V_o}{55.5} - 9i = 0$$

$$10i = -\frac{45i + V_o}{55.5}$$

$$600i = V_o$$

$$\frac{V_o}{i} = 600 \text{ k}\Omega = 0.6 \text{ M}\Omega$$

T4. (44.4)

• In the given circuit,

$$\text{Feedback factor, } \beta = \frac{R_1}{R_1 + R_2} = \frac{1}{80}$$

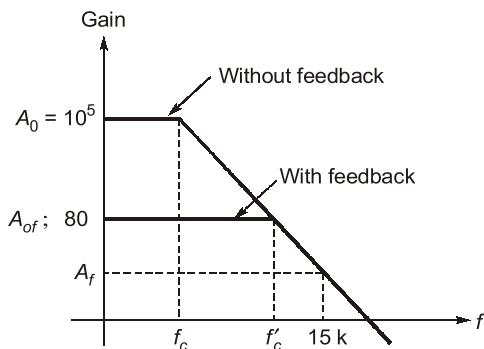

T6. (-2.5)

$$\frac{V_{in} - 0}{R} = 0 + I_C$$

$$\frac{V_{in}}{R} = C \frac{dV_C}{dt} = C \frac{d}{dt}(0 - V_{out})$$

$$-\frac{V_{in}}{RC} = \frac{dV_{out}}{dt}$$

$$V_{out} = \frac{-1}{RC} \int V_{in} dt$$

$$V_{out} =$$

$$\frac{-1}{10^3 \times 2 \times 10^{-6}} \int V_{in} dt$$

$$V_{out} = \frac{-10^3}{2} \int V_{in} dt \text{ Volt}$$

$0 < t < 1 \text{ ms} :$

$$V_{in} = 5 \text{ volt}$$

$$V_{out} = -\frac{10^3}{2} \times 5(t)$$

at $t = 1 \text{ ms}$

3

$$V_{out} = -10^3 \times 2.5 \times 1 \times 10^{-3}$$

$$= -2.5 \text{ volt}$$

$1 \text{ ms} < t < 2 \text{ ms} :$

$$V_{in} = 0 \text{ volt}$$

$$V_{out} = -2.5 \text{ volt}$$

\therefore at $t = 2 \text{ ms}, V_{out} = -2.5 \text{ volt}$

\Rightarrow applying KCL at node X—

$$\frac{1}{2} + \frac{1-V_{01}}{R} + \frac{1-0}{R} = 0$$

and $V_{01} = 3 \text{ mV}$
 $V_{out2} =$

$$1 \times \left(\frac{-R}{R} \right) = -1 \text{ mV}$$

T8. 15.39

$$f = \frac{1}{2\pi RC} = \frac{1}{2 \times 22 \times 10^3 \times 0.47 \times 10^{-6}} = 15.39 \text{ Hz}$$

T9. 8.109

$$V_{sat} = 5 \text{ V}, \text{ UTP} = 3 \text{ V}, \text{ LTP} = 2 \text{ V}$$

$$V_c(t) = V_{final} + (V_{initial} - V_{final}) e^{-t/\tau}$$

$$\therefore \text{UTP} = V_{sat} + (LTP - V_{sat}) e^{-T_1/RC}$$

$$e^{-T_1/RC} = \left[\frac{V_{sat} - \text{UTP}}{V_{sat} - \text{LTP}} \right]$$

$$\therefore \text{Total, } T = 2T_1 = 2RC \ln \left[\frac{5-2}{5-3} \right]$$

$$\therefore T = 8.109 \text{ m-sec.}$$

■■■■

T7. (a)

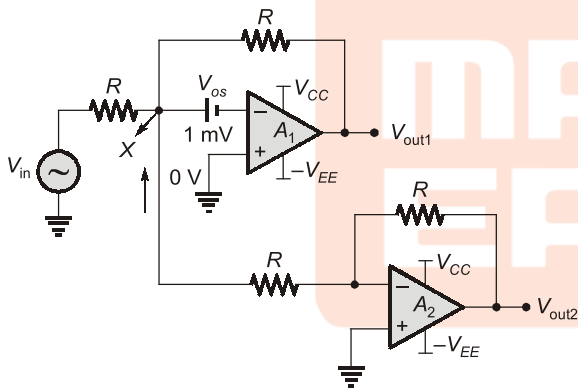

11

Sinusoidal Oscillator



Detailed Explanation of Try Yourself Questions

T1. (a)

The output can be ± 12 V only,
when output is 12 V then

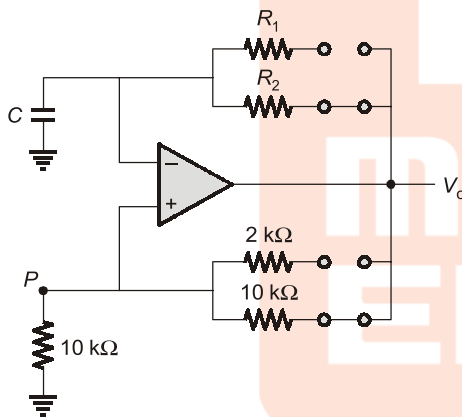

So, $V_p = 6$ V
when output is -12 V then

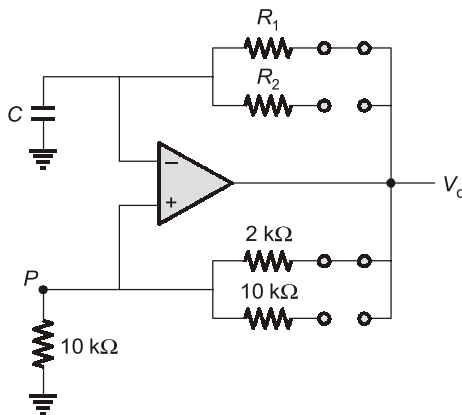

So, $V_p = -10$ V

T2. (a)

Since there are 3 capacitors the maximum phase shift that can be provided will be 270° but due to the presence of the RC circuit the phase shift is equal to 60° for the individual RC circuit, making the phase shift of the feedback network equal to 180° . Thus the amplifier should be an inverting amplifier so that it can be a positive feedback circuit and because the amplifier is a practical amplifier thus $|A\beta| > 1$ for the circuit to work.



T1. (a)

The duty cycle of the above astable multivibrator (designed using 555 timer) is

$$\therefore \frac{T_{\text{on}}}{T} = \frac{R_A + R_B}{R_A + 2R_B} \text{ thus Duty cycle} > 50\%$$

