

ESE GATE PSUs

State Engg. Exams

MADE EASY
WORKBOOK 2027



**Detailed Explanations of
Try Yourself *Questions***

ELECTRICAL ENGINEERING

Power Electronics & Drives



1

Power Semiconductor Devices



Detailed Explanation of Try Yourself Questions

T1 : Solution

(c)

Devices mentioned in figure 2 and 4 allow current flow in both direction.

T2 : Solution

(d)

$$\begin{aligned}\left(\frac{di}{dt}\right)_{\max} &= \left(\frac{V_{s\max}}{L}\right) \\ &= \frac{\sqrt{2} \times 230}{15 \times 10^{-6}} = 21.685 \text{ A}/\mu\text{s} \\ \left(\frac{dv}{dt}\right)_{\max} &= R_s \left(\frac{di}{dt}\right)_{\max} = 10 \times 21.685 \\ &= 216.85 \text{ V}/\mu\text{sec}\end{aligned}$$

T3 : Solution

(d)

KVL in the loop is, $-V + L \frac{di}{dt} = 0$

$$V = L \frac{di}{dt}$$

$$dt = \frac{L}{V} di$$

Integrating on both sides, $\int dt = \int \frac{L}{V} di$

$$t_{\min} = \frac{0.1}{100} \times 4 \times 10^{-3} = 4 \mu\text{s}$$

∴ The minimum width of the gating pulse required to properly turn on the SCR is 4 μs.

T4 : Solution

(a)

During interval t_2 , voltage starts decreasing and becomes zero and current starts increasing and becomes constant (I), so transition is turn on.

$$\int dt = \int \frac{L}{V} di$$

During t_1 interval,

power loss = vi

$$E_1 = \text{Energy loss} = \int v i dt = V \int i dt$$

V is constant during this period, $v = V$

$\int i dt$ represents area under i - t curve

$$\int i dt = \frac{1}{2} \times I \times t_1$$

$$E_1 = V \int i dt = \frac{1}{2} V I t_1 \quad \dots(i)$$

During t_2 interval, Power loss = vi

$$E_2 = \text{Energy loss} = \int v i dt = I \int v dt$$

i is constant during this period $i = I$

$\int v dt$ represents area under v - t curve

$$\int v dt = \frac{1}{2} V I t_2$$

$$E_2 = I \int v dt = \frac{1}{2} V I t_2 \quad \dots(ii)$$

Total energy lost during the transition

$$E = E_1 + E_2 = \frac{1}{2} V I t_1 + \frac{1}{2} V I t_2$$

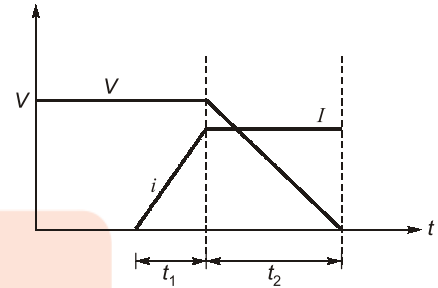

T5 : Solution

(b)

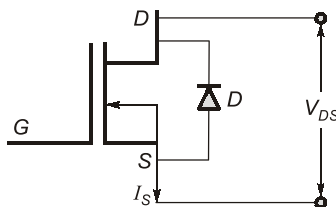

When reverse current flows through diode D .

So, $I_S < 0$ and $V_{DS} = 0$

When MOSFET is in ON state,

$$I_s > 0 \text{ and } V_{DS} = 0$$

When MOSFET is in OFF state,

$$I_s = 0 \text{ and } V_{DS} > 0$$

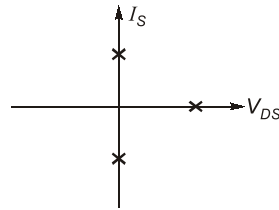

T6 : Solution

(c)

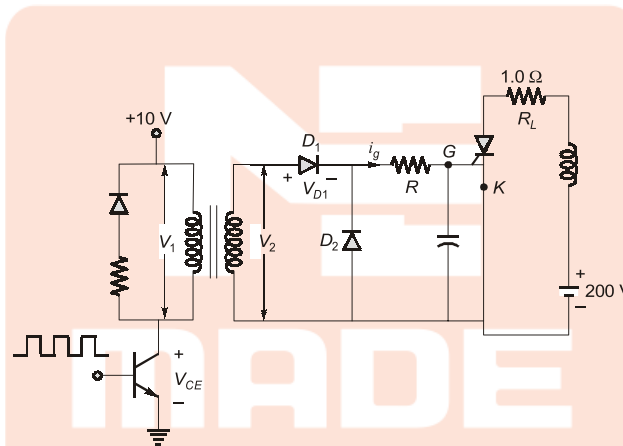

When the pulses are applied to the base of the transistor. Transistor operates in ON state. So, the forward voltage drop in transistor $V_{CE} = 1 \text{ V}$.

$$V_1 = 10 - V_{CE} = 10 - 1 = 9 \text{ V}$$

$$V_2 = V_1 \left(\frac{1}{1} \right) = V_1 = 9 \text{ V} \quad [\text{turn ratio } 1 : 1]$$

D_1 is forward biased and voltage drop in diode $V_{D1} = 1 \text{ V}$.

D_2 is reversed biased and acts as open circuit.

Capacitor behaves as open circuit for DC voltage. Forward voltage drop of gate cathode junction

$$V_{gk} = 1 \text{ V}$$

Voltage drop across resistor R ,

$$V_R = V_2 - V_{D1} - V_{gk} = 9 - 1 - 1 = 7 \text{ V}$$

To ensure turn -ON of SCR,

$$R = \frac{V_R}{I_{g(\max)}} = \frac{7}{150 \text{ mA}} \approx 47 \Omega$$

T7 : Solution

(a)

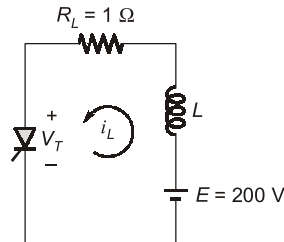

Forward voltage drop of SCR during ON-state

$$V_T = 1 \text{ V}$$

$$E - \frac{L di_a}{dt} - R i_a - V_T = 0$$

$$\Rightarrow 200 - 0.15 \frac{di_a}{dt} - i_a - 1 = 0$$

$$\Rightarrow i_a = 199(1 - e^{-t/0.15})$$

Gate pulse width required = time taken by i_a to rise upto $I_L = T$

$$\Rightarrow 250 \times 10^{-3} = 199(1 - e^{-T/0.15})$$

$$T = 188.56 \mu\text{s}$$

Width of the pulse,

$$T = 188.56 \mu\text{s}$$

Magnitude of voltage,

$$V = 10 \text{ V}$$

Voltage second rating of PT

$$VT = T = 10 \times 188.56 \mu\text{s} = 1885.6 \text{ V-s} \approx 2000 \mu\text{s}$$

T8 : Solution

(d)

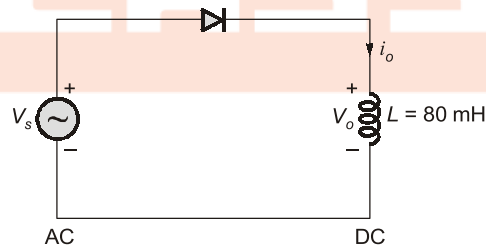

$$V_s = 230 \cos \omega t$$

$$\omega = 314 \text{ rad/sec}$$

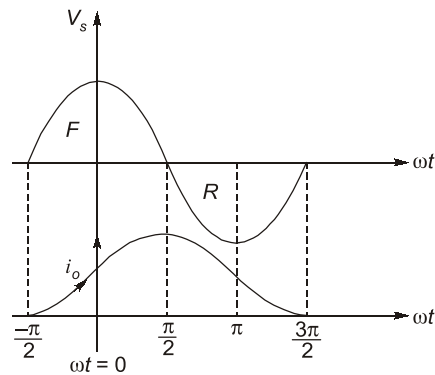

Diode will turn on at $\omega t = -\frac{\pi}{2}$

Applying KVL

$$V_s = V_o$$

$$V_m \cos \omega t = L \frac{di}{dt}$$

$$\int di = \int \frac{V_m \cos \omega t}{L} dt$$

$$i_o = \frac{V_m}{\omega L} \sin \omega t + K$$

At $\omega t = -\frac{\pi}{2}$,

$$i_o = 0$$

$$0 = \frac{V_m}{\omega L} \sin\left(-\frac{\pi}{2}\right) + K$$

$$K = \frac{V_m}{\omega L}$$

$$i_o = \frac{V_m}{\omega L} \sin \omega t + \frac{V_m}{\omega L}$$

At $\omega t = \frac{\pi}{2}$

$$\begin{aligned} i_{\text{peak}} &= \frac{V_m}{\omega L} \sin \frac{\pi}{2} + \frac{V_m}{\omega L} \\ &= \frac{2V_m}{\omega L} = \frac{2 \times 230}{314 \times 80 \times 10^{-3}} \\ &= 18.31 \text{ A} \end{aligned}$$

T9 : Solution

$$(I_T)_{\text{RMS rating}} = 35 \text{ A}$$

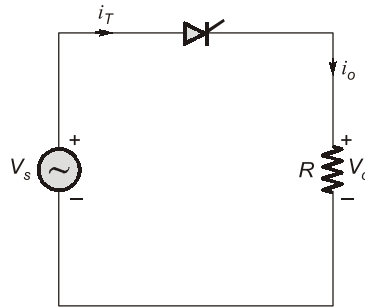

$$i_T = i_o$$

$$\text{Form factor} = \frac{(I_T)_{\text{RMS}}}{(I_T)_{\text{Avg}}}$$

$$= \frac{I_{or}}{I_o}$$

$$= \frac{V_{or}/R}{V_o/R}$$

$$= \frac{V_{or}}{V_o}$$

$$\text{Form factor} = \frac{\frac{V_m}{\sqrt{2} \times 2\pi} \left\{ (\pi - \alpha) + \frac{1}{2} \sin 2\alpha \right\}^{\frac{1}{2}}}{\frac{V_m}{2\pi} [1 + \cos \alpha]} = 3.98$$

Put $\alpha = \frac{\pi}{6}$

Note : At $\alpha = 0$, conduction angle of SCR is maximum.

$$\begin{aligned} (I_T)_{\text{Avg rating}} &= \frac{(I_T)_{\text{RMS Rating}}}{\text{Form Factor}} \\ &= \frac{35}{FF} \\ &= \frac{35}{3.98} = 8.79 \end{aligned}$$

T10 : Solution

(c)

(ii)

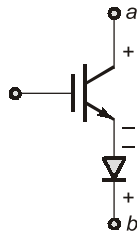

- As given that the active device is in OFF state it means the device can block the voltage when 'a' is positive with respect to 'b' and when 'b' is positive with respect to 'a' then the diode is reverse biased and voltage is blocked.

(iii)

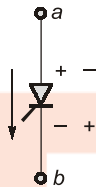

- When 'a' is positive with respect to 'b', as given the device is OFF so it will block the voltage.
- When 'b' is positive with respect to 'a' it will block the voltage.
- Where as the other two devices will conduct when 'b' is positive with respect to 'a'.

T11 : Solution

(c)

Derating factor = 1 – String efficiency

$$0.2 = 1 - \frac{6000}{n_s \times 1000} = 1 - \frac{1000}{n_p \times 200}$$

$$n_s = 7.5 \approx 8$$

$$n_p = 6.25 \approx 7$$

T12 : Solution

(b)

Given :

Junction temperature, $T_j = 125^\circ\text{C}$

Thermal resistance of junction to case, $\theta_{jc} = 0.16^\circ\text{C/W}$

Thermal resistance of case to sink, $\theta_{cs} = 0.08^\circ\text{C/W}$

Heat sink initial temperature, $T_{s1} = 70^\circ\text{C}$

Final heat sink temperature, $T_{s2} = x^\circ\text{C}$

With T_{s1} , average power dissipation,

$$P_{av1} = \frac{T_j - T_{s1}}{\theta_{jc} + \theta_{cs}} = \frac{125^\circ - 70^\circ}{0.16 + 0.08}$$

$$= 229.17 \text{ W}$$

With T_{s2} , average power dissipation,

$$P_{av2} = \frac{125^\circ - x^\circ}{0.16 + 0.08} = \frac{125^\circ - x^\circ}{0.24} \quad \dots(1)$$

Given : $\% \text{ increase in device rating} = \frac{\sqrt{P_{av_2}} - \sqrt{P_{av_1}}}{\sqrt{P_{av_1}}} \times 100$

$\Rightarrow 8.71 = \frac{\sqrt{P_{av_2}} - \sqrt{229.17}}{\sqrt{229.17}} \times 100$

$\Rightarrow \frac{\sqrt{P_{av_2}} - 15.14}{15.14} = 0.0871$

$\Rightarrow P_{av_2} = 270.83 \text{ W}$

From eqn. (2), $270.83 = \frac{125^\circ - x^\circ}{0.24}$

$\Rightarrow x = 60^\circ$



2

Controlled and Uncontrolled Rectifiers



Detailed Explanation of Try Yourself Questions

T1 : Solution

(b)

Average output voltage

$$V_0 = \frac{2V_m}{\pi} \cos \alpha = \frac{2\sqrt{2} \times 230}{\pi} \cos 45^\circ = 146.42 \text{ V}$$

$$I_0 = \frac{V_0}{R} = \frac{146.42}{10} = 14.642 \text{ A}$$

Reactive power input to the converter is

$$Q_i = \frac{2V_m}{\pi} I_0 \sin \alpha$$

$$= \frac{2\sqrt{2} \times 230}{\pi} \times 14.642 \times \sin 45^\circ$$

$$Q_i = 2143.92 \text{ VAR}$$

T2 : Solution

$$V_0 = L \frac{di}{dt} = V_s$$

$$\int di = \int \frac{V_s}{L} dt = \int \frac{100 \sin \omega t}{L} dt$$

$$i_0 = -\frac{100}{\omega L} \cos \omega t + K$$

$$\omega t = 100\pi \times 2.5 \times 10^{-3} = \frac{\pi}{4}$$

$$i_0(t = 2.5 \text{ ms}) = 0$$

$$\frac{-100 \cos 45^\circ}{100\pi \times 31.83 \times 10^{-3}} + K = 0$$

$$K = 7.07$$

$$i_0 = -10 \cos \omega t + 7.07$$

$$i_{0, \text{ peak}} = -10 \cos \pi + 7.07$$

$$= 17.07 \text{ A}$$

T3 : Solution

The half-wave diode rectifier uses a step-up transformer, therefore, ac voltage applied to rectifier
 $= 230 \times 460 \text{ V} = V_s$

Average value of load voltage

$$V_0 = \frac{V_m}{\pi} = \frac{\sqrt{2} \times 460}{\pi} = 207.04 \text{ V}$$

Output dc power, $P_{dc} = \frac{V_0^2}{R} = \frac{207.04^2}{60} = 714.43 \text{ W}$

It is seen from the table that *TUF* for 1-phase half-wave diode rectifier is 0.2865.

$$\therefore \text{VA rating of transformer} = \frac{P_{dc}}{TUF} = \frac{714.43}{0.2865} = 2493.65 \text{ VA}$$

So, choose a transformer with 2.5 kVA (next round figure) rating.

T4 : Solution

(1.05)

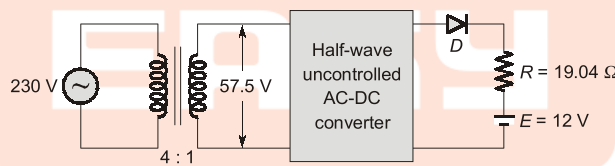

Input to the converter, $V_s = \left(\frac{1}{4}\right) 230 = 57.5 \text{ V}$

Diode conducts when $V_s \geq E$

$$V_m \sin \theta_1 = E$$

$$57.5\sqrt{2} \sin \theta_1 = 12$$

$$\theta_1 = 8.486^\circ \text{ or } 0.148 \text{ rad}$$

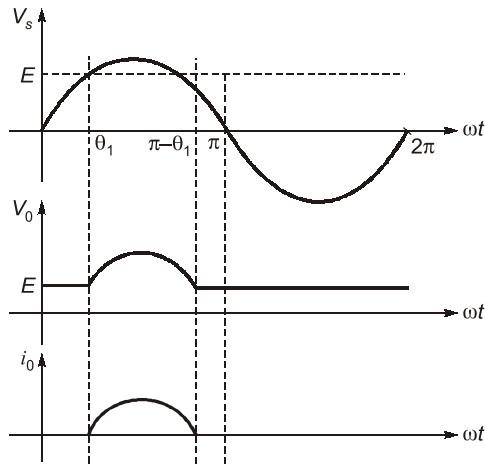

Charging current flows during $\theta_1 \leq \omega t \leq \pi - \theta_1$ and can be expressed as,

$$I_0 = \frac{1}{2\pi} \int_0^{2\pi} i_0 d\omega t = \frac{1}{2\pi} \int_{\theta_1}^{\pi - \theta_1} \left(\frac{V_m \sin \omega t - E}{R} \right) d\omega t$$

$$I_0 = \frac{1}{2\pi R} [2V_m \cos \theta_1 - E(\pi - 2\theta_1)]$$

$$= \frac{1}{2\pi \times 19.04} [2 \times 57.5\sqrt{2} \times \cos 8.486^\circ - 12 \times (\pi - 2 \times 0.148)]$$

$$= 1.05 \text{ A}$$

T5 : Solution

(d)

Lower limit,
Upper limit,

$$\alpha = 60^\circ, V_{YB} = V_{ML} \sin \omega t \text{ (Ref)}$$

$$L = 60 + \alpha = 120^\circ = \frac{2\pi}{3} \text{ rad}$$

$$U = 120 + \alpha = 180^\circ = \pi \text{ rad}$$

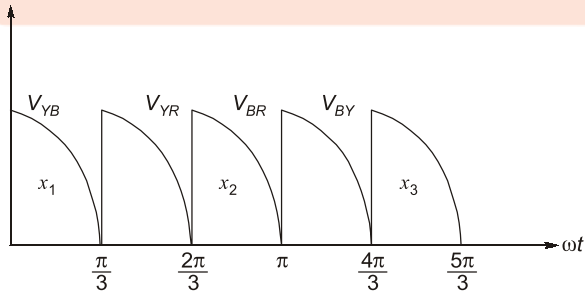

$$x_1 \rightarrow V_{RY}$$

$$x_2 \rightarrow V_{YB}$$

$$x_3 \rightarrow V_{BR}$$

T6 : Solution

(d)

THD is a measure of the harmonic content in the input supply current I . In case of single-phase diode rectifier with capacitive filter the ac input current waveform is not smooth and have maximum harmonic content.

T7 : Solution

(c)

Frequency of the voltage source, $f = 50$ Hz

Time period, $T = \frac{1}{f} = \frac{1}{50} = 20$ ms .

During positive half cycle of the source voltage, $0 < t < \frac{T}{2}$, energy is stored in the inductor and current increases.

During negative half cycle of the source voltage, $\frac{T}{2} \leq t \leq T$, current decreases and energy stored in the inductor is delivered to source.

T8 : Solution

(b)

$$V_s = 100\sqrt{2} \sin(100\pi t)$$

$$i = 10\sqrt{2} \sin\left(100\pi t - \frac{\pi}{3}\right) + 5\sqrt{2} \sin\left(300\pi t + \frac{\pi}{4}\right) + 2\sqrt{2} \sin\left(500\pi t - \frac{\pi}{6}\right) \text{ A}$$

$$\begin{aligned} \text{Active power} &= V_{sr} I_{s1} \cos \phi_1 \\ &= 100 \times 10 \times \cos 60^\circ \\ &= 500 \text{ W} \end{aligned}$$

T9 : Solution

(b)

Rms value of input voltage,

$$V_{\text{rms}} = \frac{100\sqrt{2}}{\sqrt{2}} = 100 \text{ V}$$

Rms value of current,

$$I_{\text{rms}} = \sqrt{\left(\frac{10\sqrt{2}}{\sqrt{2}}\right)^2 + \left(\frac{5\sqrt{2}}{\sqrt{2}}\right)^2 + \left(\frac{2\sqrt{2}}{\sqrt{2}}\right)^2} = 11.358 \text{ A}$$

Let input power factor $\cos \phi$

$V_{\text{rms}} I_{\text{rms}} \cos \phi =$ active power drawn by the converter

$$\Rightarrow 100 \times 11.358 \times \cos \phi = 500 \text{ W}$$

$$\Rightarrow \cos \phi = 0.44$$

T10 : Solution

(c)

$$i_s \propto \frac{I_a}{n} \cdot \cos \frac{n\pi}{6} \quad \text{where } n \in 1, 3, 5$$

For $n = 3,$

$$i_s = 0$$

For $n = 5,$

$$i_s \propto -\frac{I_a}{5}$$

Lowest harmonic present is fifth harmonic. Its frequency = $50 \times 5 = 250$ Hz.

T11 : Solution

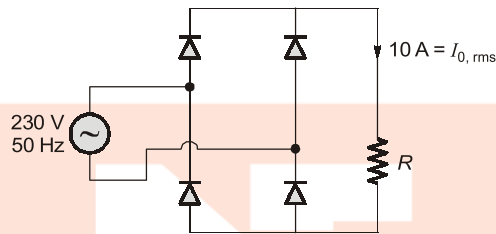

$$I_{0,rms} = \frac{V_s}{R} \Rightarrow R = \frac{230}{10} = 23 \Omega$$

T12 : Solution

(c)

T_1 and T_4 gets forward biased, when

$$V_m \sin \theta_1 \leq E$$

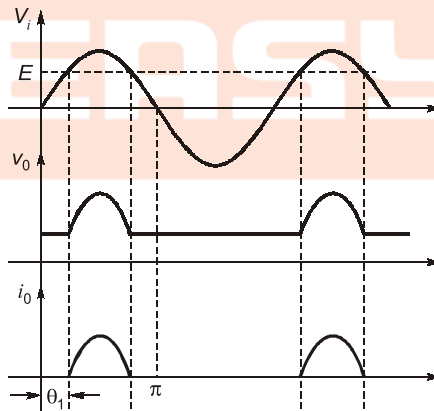

I_{avg} = (Average current)

$$= \frac{1}{2\pi R} \int_{\theta_1}^{\pi - \theta_1} (V_m \sin \omega t - E) d\theta$$

\therefore

$$I_0 \text{ (avg)} = \frac{1}{2\pi R} [2V_m \cos \theta - E(\pi - 2\theta_1)]$$

$$= \frac{1}{2\pi \times 2} [2 \times (230 \times \sqrt{2}) \cos \theta_1 - 200(\pi - 2\theta_1)]$$

where,

$$\theta_1 = \sin^{-1}\left(\frac{E}{V_m}\right)$$

$$= \sin^{-1}\left(\frac{200}{230 \times \sqrt{2}}\right) = 38^\circ = 0.66 \text{ rad}$$

$$\therefore I_0 \text{ (avg)} = \frac{1}{2\pi \times 2} [2\sqrt{2} \times 230 \cos 38^\circ - 200(\pi - 2 \times 0.66)] = 11.9 \text{ A}$$

T13 : Solution

Output waveforms of highly inductive load (without F.W. diode).

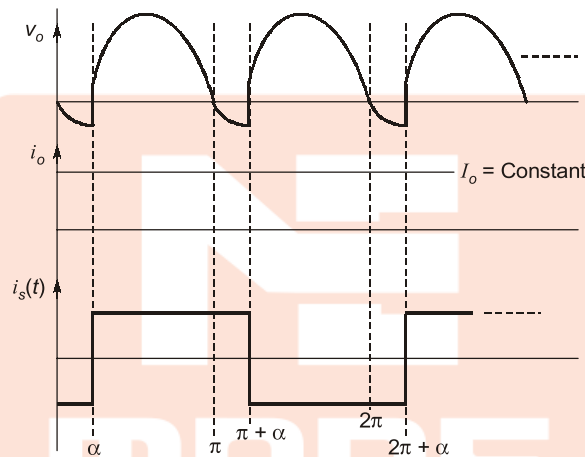

Fourier series of supply current is given as

$$i_s(t) = \sum_{n=1,3,5}^{\infty} \frac{4I_o}{n\pi} \sin n\omega_o t$$

Frequency components present in supply current is 1st, 3rd, 5th, 7th : all odd frequencies.

Two most dominant harmonics are 3rd and 5th, i.e., 150 Hz and 250 Hz.

Two most dominant frequencies are 1st and 3rd, i.e., 50 Hz and 150 Hz.

Except fundamental, all other frequencies are harmonics in supply current.

T14 : Solution

1- ϕ , SCR bridge rectifier

$$\alpha = 45^\circ, R = 10 \Omega$$

supply 230 V, 50 Hz

$$L_s = 2.28 \text{ mH}, \mu = ?$$

$$\Delta V_d = \frac{V_m}{\pi} [\cos \alpha - \cos(\alpha + \mu)] = 4f L_s I_0$$

$$V_0 = \frac{2V_m}{\pi} \cos \alpha - 4f L_s I_0 \text{ (with } L_s)$$

$$I_0 R = \frac{2V_m}{\pi} \cos \alpha - 4f L_s I_0$$

Find I_0

$$I_0 \times 10 = \frac{2 \times 230\sqrt{2}}{\pi} \cdot \cos 45 - 4 \times 50 \times 2.28 \times 10^{-3} I_0$$

$$I_0(10 + 0.456) = 146.42$$

$$I_0 = \frac{146.49}{10.456} = 14.0036 \text{ A}$$

$$\Delta V_{\alpha 0} = \frac{230\sqrt{2}}{\pi} [\cos 45 - \cos(45 + \mu)]$$

$$= 4 \times 50 \times 2.28 \times 10^{-3} \times 14 = 6.384$$

$$\cos 45^\circ - \cos(45^\circ + \mu) = 0.061659$$

$$45 + \mu = 49.80 \Rightarrow \mu = 4.80^\circ$$

T15 : Solution

$$V_o = 2 \frac{V_m}{\pi} \cos \alpha = 2 \frac{200\pi}{\pi} \cos 120^\circ$$

$$V_o = -200 \text{ V}$$

$$|V_o| = 200 \text{ V}$$

Power balance equation,

$$EI_o = I_o^2 R + V_o I_o$$

$$800 I_o = I_o^2 (20) + 200 I_o \Rightarrow I_o = 30 \text{ A}$$

$$I_o = I_{or}$$

Power fed to source

$$= V_o I_o = 200 \times 30 = 6 \text{ kW}$$

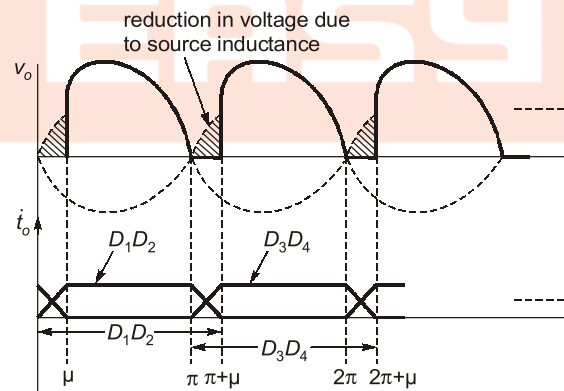
T16 : SolutionConduction angle of each diode = $\pi + \mu$ rad**Output Waveform**

$$V_{o(\text{avg})} = \frac{2V_m}{\pi} \quad (\because \text{without } L_s)$$

$$V_{o(\text{avg})} = \frac{1}{\pi} \int_{\mu}^{\pi} V_m \sin \omega t \cdot d\omega t \quad (\because \text{with } L_s)$$

$$= \frac{V_m}{\pi} [1 + \cos \mu]$$

$$\Delta V_{do} = V_{o(avg)} - V_{o(avg)} = \frac{V_m}{\pi} [1 - \cos \mu]$$

and

$$\Delta V_{do} = 4fL_s I_o \text{ [average reduction in voltage due to source inductance]}$$

On equating,

$$\frac{V_m}{\pi} [1 - \cos \mu] = 4fL_s I_o$$

$$\frac{220\sqrt{2}}{\pi} (1 - \cos \mu) = 4 \times 50 \times 10 \times 10^{-3} \times 14$$

On solving,

$$\mu = 44.17^\circ$$

So, conduction angle of each diode

$$\gamma_D = 180^\circ + \mu = 180^\circ + 44.17^\circ = 224.17^\circ$$

T17 : Solution

$$V_o = \frac{V_m}{2\pi} (3 + \cos \alpha)$$

$$E_b I_o = 1600 \text{ W}$$

$$I_o = \frac{1600}{80} = 20 \text{ A}$$

$$V_o = E_b + I_o R_a$$

$$\frac{V_m}{2\pi} (3 + \cos \alpha) = 80 + (20 \times 2)$$

$$\frac{80\pi}{2\pi} (3 + \cos \alpha) = 80 + 40$$

$$\alpha = 90^\circ$$

T18 : Solution

(0.78)

$$V_{sr} I_{sr} \cos \phi = V_o I_o$$

For single-phase fully controlled converter,

$$I_o = I_{sr} = 10 \text{ A}$$

$$\cos \phi = \frac{V_o}{V_{sr}} = \frac{180}{230} = 0.78$$

T19 : Solution

(a, c, d)

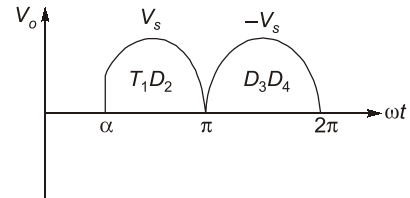
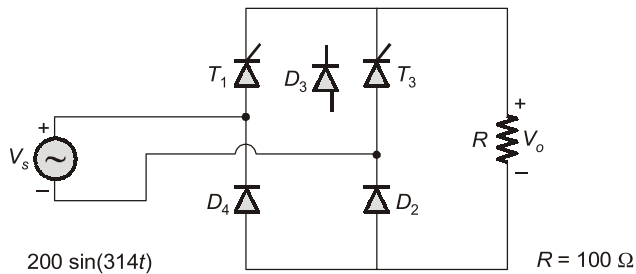

$$V_o = \frac{1}{2\pi} \left[\int_{\alpha}^{\pi} V_m \sin \omega t \cdot d\omega t + \int_{\pi}^{2\pi} -V_m \sin \omega t d\omega t \right]$$

$$V_o = \frac{V_m}{2\pi} [3 + \cos \alpha]$$

$$= \frac{200}{2\pi} [3 + \cos 60^\circ] = 111.4 \text{ V}$$

$$I_o = \frac{V_o}{R} = \frac{111.4}{100} = 1.114 \text{ A}$$

$$I_{T1, \text{avg}} = \frac{1}{2\pi} \int_{\alpha}^{\pi} \frac{V_m \sin \omega t}{R} d\omega t$$

$$I_{T1} = \frac{V_m}{2\pi R} [1 + \cos \alpha] = \frac{200}{2\pi \times 100} [1 + \cos 60^\circ]$$

$$= 0.4774 \text{ A}$$

$$\text{Power drawn by load } P_o = V_{o, \text{rms}} I_{o, \text{rms}} = \frac{V_o^2}{R}$$



3

Choppers



Detailed Explanation of Try Yourself Questions

T1 : Solution

Circuit turnoff time,

$$t_c = \frac{CV_s}{I_0} = \frac{8 \times 10^{-6} \times 250}{20} = 1 \times 10^{-4} \text{ s}$$

Maximum value of duty cycle,

$$\begin{aligned} \alpha_{\max} &= (1 - 2ft_c) \\ &= (1 - 2 \times 250 \times 1 \times 10^{-4}) \end{aligned}$$

$$\alpha_{\max} = 0.95$$

maximum load or output voltage,

$$\begin{aligned} V_{0, \max} &= V_s[\alpha_{\max} + 2ft_c] \\ &= 250[0.95 + (2 \times 250 \times 1 \times 10^{-4})] \end{aligned}$$

$$V_{0, \max} = 250 \text{ V}$$

T2 : Solution

(24)

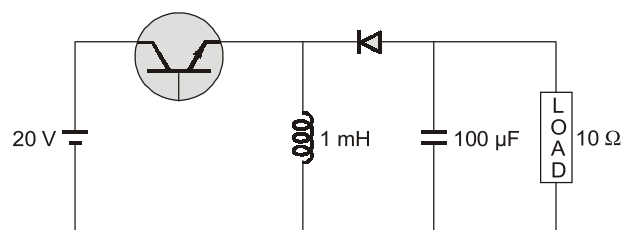

$$\alpha = 0.75, \quad f = 25 \text{ kHz}$$

Assume continuous conduction:

$$V_o = \frac{\alpha V_s}{1 - \alpha} = \frac{0.75 \times 20}{1 - 0.75}$$

$$V_o = 60 \text{ V}$$

$$I_o = \frac{V_o}{R} = \frac{60}{10} = 6 \text{ A}$$

$$I_L = \frac{I_o}{1 - \alpha} = \frac{6}{1 - 0.75} = 24 \text{ A}$$

$$\Delta I_L = \frac{\alpha V_s}{f_L}$$

$$= \frac{0.75 \times 60}{25 \times 10^3 \times (1 \times 10^{-3})} = 1.8 \text{ A}$$

$$I_{L \min} = I_L - \frac{\Delta I_L}{2} = 24 - \frac{1.8}{2} = 24 - 0.9$$

$$(I_{L \min} = 23.1 \text{ A}) > 0$$

∴ Continuous conduction assumption is correct.

$$I_L = 24 \text{ A}$$

T3 : Solution

(c)

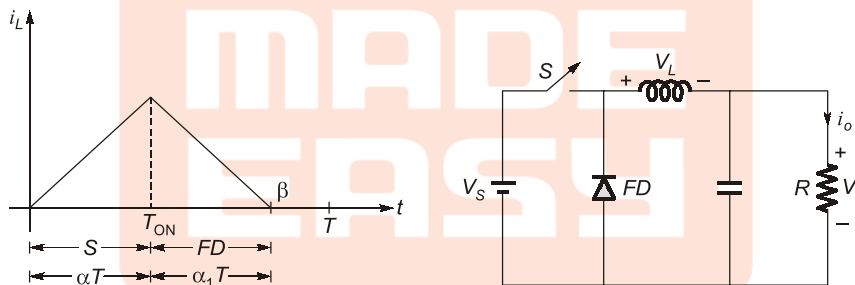

$S \rightarrow \text{ON} :$

KVL :

$$-V_s + V_L + V_o = 0$$

$$V_L = V_s - V_o$$

$$L \frac{di_L}{dt} = V_s - V_o$$

$$\frac{di_L}{dt} = \frac{V_s - V_o}{L}$$

$R \uparrow, I_o \downarrow$

∴ $I_L \downarrow$ ∴ Area \downarrow ∴ $\beta \downarrow$ ∴ $V_o \uparrow$

$$\uparrow V_o = \frac{\alpha V_s}{\beta \downarrow}$$

$S \rightarrow \text{OFF}, FD \rightarrow \text{ON}$

$$V_L + V_o = 0$$

$$V_L = -V_o$$

$$L \frac{di_L}{dt} = -V_o$$

$$\frac{di_L}{dt} = \frac{-V_o}{L}$$

T4 : Solution

(a)

Boost converter,

$$V_0 = \frac{V_s(1-\alpha)}{\frac{r}{R} + (1-\alpha)^2} \text{ (Practical transfer function for Boost Converter)}$$

$$\alpha = 1, V_0 = 0$$

T5 : Solution

(c)

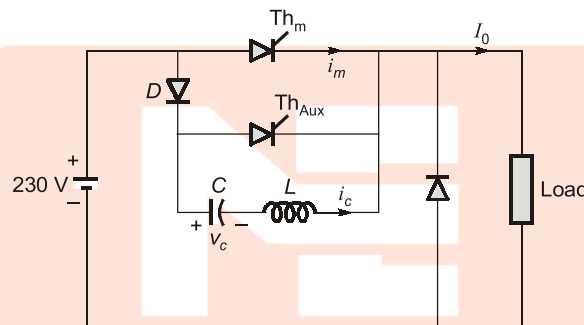

At $t = 0^-$, $v_c = V_s$, $i_c = 0$ and $i_{T1} = I_0$.

At $t = 0$, Th_{aux} is triggered, a resonant current i_c designs to flow from C through Th_{aux} , L and back to C .

This resonant current is given by

$$\begin{aligned} i_c &= -V_s \sqrt{\frac{C}{L}} \sin \omega_0 t \\ &= -I_p \sin \omega_0 t \end{aligned}$$

After half a cycle of i_c $\left\{ t_1 = \frac{\pi}{\omega_0} \right\}$;

$i_c = 0$, $v_c = -V_s$ and $i_{T1} = I_0$. As i_c tends to reverse, Th_{aux} is turned off.

When $v_c = -V_s$, right hand plate has positive polarity, resonant current i_c now builds up through C , L , D and Th_m . As this current i_c grows opposite to forward thyristor current of Th_m , net forward current $i_m = I_0 - i_c$ begins to decrease. Finally when i_c in the reversed direction attains the value I_0 , i_m is reduced to zero and Th_m is turned off.

$$\begin{aligned} i_m &= I_0 - i_c \\ &= I_0 - I_p \sin \omega_0 \Delta t = 0 \end{aligned}$$

$$\Delta t = \frac{1}{\omega_0} \sin^{-1} \left(\frac{I_0}{I_p} \right)$$

So, Th_m is turned off between

$$t_1 < t < t_1 + \Delta t$$

$$\begin{aligned}
 t_1 &= \frac{\pi}{\omega_0} = \pi\sqrt{LC} \\
 &= \pi \times \sqrt{10 \times 25.28} \\
 &= 50 \mu \text{ sec}
 \end{aligned}$$

Option (c) is correct.

Since, commutation of Th_m starts from $t_1 = 50 \mu\text{sec}$.

T6 : Solution

(1.60)

Checking for continuous conduction mode

$$\Delta I_L = \frac{\alpha V_S}{fL} = \frac{0.6 \times 15}{25 \times 10^3 \times 1 \times 10^{-3}} = 0.36 \text{ A}$$

$$\frac{\Delta I_L}{2} = 0.18 \text{ A}$$

$$\begin{aligned}
 I_{L,\min} &= I_L - \frac{\Delta I_L}{2} = I_S - \frac{\Delta I_L}{2} \\
 &= (9.375 - 0.18) = 9.195 > 0
 \end{aligned}$$

As it is continuous conduction

$$V_o = \frac{V_S}{1-\alpha} = \frac{15}{1-0.6} = 37.5 \text{ V}$$

$$I_o = \frac{V_o}{R} = \frac{37.5}{10} = 3.75 \text{ A}$$

$$\frac{V_o}{V_S} = \frac{I_S}{I_o} = \frac{1}{1-\alpha}$$

$$I_S = \frac{I_o}{1-\alpha} = \frac{3.75}{1-0.6} = 9.375 \text{ A}$$

$$R_{in} = \frac{V_S}{I_S} = \frac{15}{9.375} = 1.6 \Omega$$

T7 : Solution

(b)

Stepdown chopper:

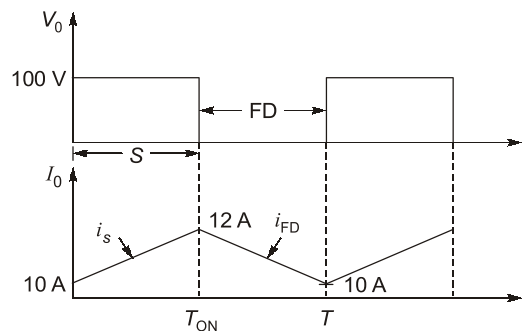

$$\tau = \frac{L}{R} = \frac{40 \cdot 10^{-3}}{5} = 8 \cdot 10^{-3}$$

$$V_0 = \alpha V_s$$

S → ON:

$$V_s = Ri_s + L \frac{di_s}{dt}$$

$$\begin{aligned} i_s &= \frac{V_s}{R} \left(1 - e^{-t/8 \cdot 10^{-3}}\right) + 10 \cdot e^{-t/8 \cdot 10^{-3}} \\ &= \frac{100}{5} \left(1 - e^{-t/8 \cdot 10^{-3}}\right) + 10 \cdot e^{-t/8 \cdot 10^{-3}} \\ &= 20 \left(1 - e^{-t/8 \cdot 10^{-3}}\right) + 10 \cdot e^{-t/8 \cdot 10^{-3}} \end{aligned}$$

At $t = T_{ON}$,

$$i_s = 20 - 10 e^{-t/8 \cdot 10^{-3}}$$

$$i_s = 12 \text{ A}$$

∴

$$12 \text{ A} = 20 - 10 e^{-t/8 \cdot 10^{-3}}$$

$$10 e^{-T_{ON}/8 \cdot 10^{-3}} = 8$$

$$e^{-T_{ON}/8 \cdot 10^{-3}} = 0.8$$

$$\frac{-T_{ON}}{8 \cdot 10^{-3}} = -0.223$$

$$T_{ON} = 1.785 \times 10^{-3} = 1.785 \text{ ms}$$

FD → ON:

$$i_{FD} = 12 \cdot e^{-t'/\tau}$$

$$= 12 \cdot e^{-t'/8 \cdot 10^{-3}}$$

At $t' = T_{OFF}$,

$$i_{FD} = 10 \text{ A}$$

$$10 = 12 \cdot e^{-T_{OFF}/8 \cdot 10^{-3}}$$

$$e^{-T_{OFF}/8 \cdot 10^{-3}} = \frac{10}{12}$$

$$\frac{-T_{OFF}}{8 \cdot 10^{-3}} = -0.182$$

$$T_{OFF} = 1.458 \text{ ms}$$

$$\text{Time ratio} = \frac{T_{ON}}{T_{OFF}} = \frac{1.785}{1.458} = 1.22$$

Alternate Solution :

$$I_{\alpha(\text{avg})} = \frac{I_{\alpha(\text{max})} + I_{\alpha(\text{min})}}{2}$$

$$I_{\alpha(\text{avg})} = \frac{12 + 10}{2} = 11 \text{ A}$$

$$V_{\alpha(\text{avg})} = I_{\alpha(\text{avg})} \times R$$

$$= 11 \times 5 = 55 \text{ V}$$

and

$$V_{\alpha(\text{avg})} = \frac{T_{\text{on}}}{T} V_s$$

$$\frac{55}{100} = \frac{T_{\text{on}}}{T}$$

$$\frac{T_{\text{off}}}{T} = \frac{T - T_{\text{on}}}{T} = \frac{45}{100} T$$

So,

$$\frac{T_{\text{on}}}{T_{\text{off}}} = \frac{55}{45} = \frac{11}{9} = 1.222$$

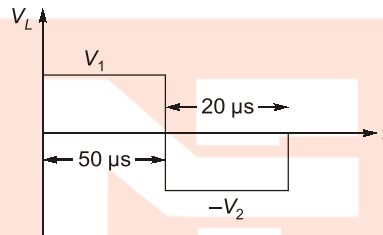
T8 : Solution

$$V_1 \times 50 \mu\text{sec} = V_2 \times 20 \mu\text{sec} = 0$$

$$\frac{V_1}{V_2} = \frac{2}{5}$$

T9 : Solution**(2500)**

On the verge of discontinuity

$$L = L_c \text{ (critical inductance)}$$

$$I_{L,\text{min}} = 0$$

$$I_{L(\text{avg})} - \frac{\Delta I_L}{2} = 0 \Rightarrow I_{L(\text{avg})} = \frac{\Delta I_L}{2}$$

$$I_{L(\text{avg})} = \frac{D(1-D) \cdot V_s}{2fL} \quad \{ \because I_{L(\text{avg})} = I_{\alpha(\text{avg})} \}$$

$$\frac{V_{\alpha(\text{avg})}}{R} = \frac{D(1-D)V_s}{2fL}$$

$$\frac{36}{R} = \frac{60 \times 0.4 \times 0.6}{2 \times 100 \times 10^3 \times 5 \times 10^{-3}}$$

On solving, $R = 2500 \Omega$

T10 : Solution

(Sol)

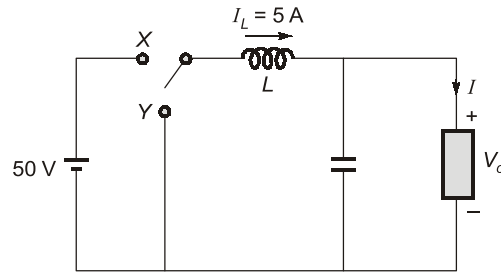

Inductor current i_L is constant and ripple free.
Thus, when switch is at position 'X' :

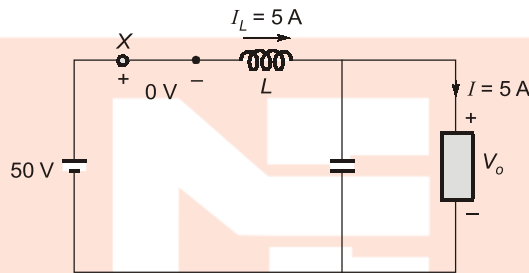

Assuming ideal components

KVL :

$$-50 + 0 + V_o = 0 \quad (\because V_{L(\text{ang})} = 0 \text{ and voltage across the ideal switch is always zero})$$

$$V_o = 50 \text{ Volts}$$

and

$$I = I_L = 5 \text{ A} \quad (\because \text{capacitor block dc currents under steady state})$$

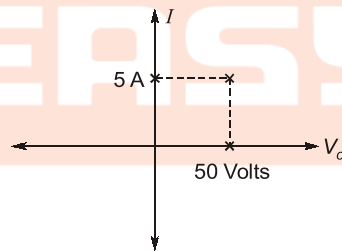

When switch is at position 'Y'

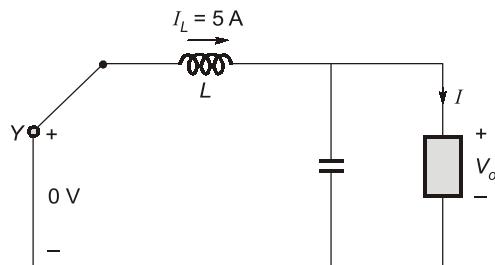

By KVL :

$$0 + V_o = 0 \quad (\because \text{Voltage across the ideal switch is always zero})$$

$$V_o = 0 \text{ Volts} \quad (\because \text{Voltage across the ideal switch is always zero})$$

and

$$I = I_L = 5 \text{ A}$$

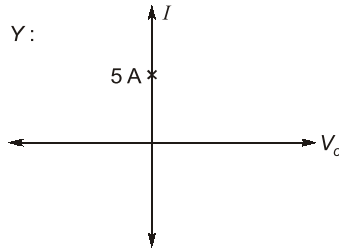

T11 : Solution

Buckboost converter,

$$V_o = \frac{\alpha V_s}{1 - \alpha}$$

$$V_s = 50 \text{ V}$$

$$\alpha = 0.6$$

$$V_o = 75 \text{ V}$$

$$\frac{V_o}{V_s} = \frac{I_s}{I_o} = \frac{\alpha}{1 - \alpha} = \frac{0.6}{1 - 0.6} = \frac{0.6}{0.4} = \frac{3}{2}$$

$$I_o = \frac{V_o}{R} = \frac{75}{5} = 15 \text{ A}$$

$$I_s = \frac{\alpha}{1 - \alpha} \cdot I_o = \frac{3}{2} \times 15 = 22.5 \text{ A}$$

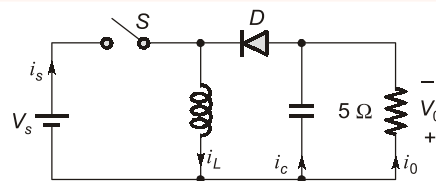
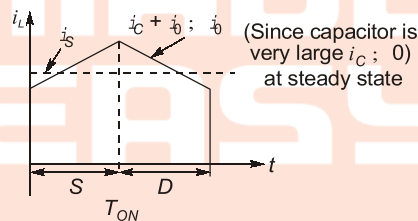

Since capacitor is very large $i_c = 0$ at steady state

$$(i_L)_{avg} = (i_s)_{avg} + (i_o)_{avg}$$

$$I_L = I_s + I_o$$

$$I_L = 22.5 + 15 = 37.5 \text{ A}$$

∴

$$I_L = 37.5 \text{ A}$$

$$\Delta I_L = \frac{\alpha V_s}{fL} = \frac{0.6 \times 50}{10 \times 10^3 \times (0.6 \times 10^{-3})} = 5 \text{ A}$$

$$(i_L)_{\text{peak}} = I_L + \frac{\Delta I_L}{2} = 37.5 + \frac{5}{2} = 40 \text{ A}$$

∴ Peak value of current drawn from source

$$= (i_L)_{\text{peak}} = 40 \text{ A}$$

T12 : Solution

(a, c)

$$I_o = 10 \text{ A}$$

$$\alpha = 0.45$$

$$f = 80 \text{ kHz}$$

$$L = 10 \text{ mH}$$

$$C = 120 \mu\text{F}$$

$$I_S = I_L = \frac{I_o}{1-\alpha} = \frac{10}{1-0.45} = 18.18 \text{ A}$$

$$\Delta V_C = AV_o = \frac{\alpha I_o}{fC} = \frac{0.45 \times 10}{80 \times 10^3 \times 120 \times 10^{-6}} = 0.468 \text{ V}$$

$$I_{S0} = \alpha I_S = 0.45 \times 18.18 = 8.18 \text{ A}$$

T13 : Solution

(a)

Apply boundary conditions,

$$I_L = \frac{\Delta I_L}{2}$$

Inductor current,

$$I_L = \frac{I_o}{1-D}$$

∴

$$\frac{I_o}{1-D} = \frac{DV_s}{2fL}$$

$$\frac{V_s}{R(1-D)^2} = \frac{DV_s}{2fL}$$

$$f = \frac{D(1-D)^2 R}{2L} = \frac{0.6 \times (1-0.6)^2 \times 50}{2 \times 100 \times 10^{-6}}$$

$$f = 24 \text{ kHz}$$

■■■■

4

Inverters



Detailed Explanation of Try Yourself Questions

T1 : Solution

$$R_{\Delta} = 30 \Omega/\text{phase}$$

$$R_Y = 10 \Omega/\text{phase}$$

$$V_{0, \text{line}} = V_s \sqrt{\frac{2}{3}}$$

$$V_{0, \text{phase}} = \frac{V_s \sqrt{2}}{3} = \frac{600\sqrt{2}}{3} = 200\sqrt{2} \text{ V}$$

$$P_0 = \frac{3V_{0, \text{phase}}^2}{R} = \frac{3 \times (200\sqrt{2})^2}{10} = 24 \text{ kW}$$

T2 : Solution

(a)

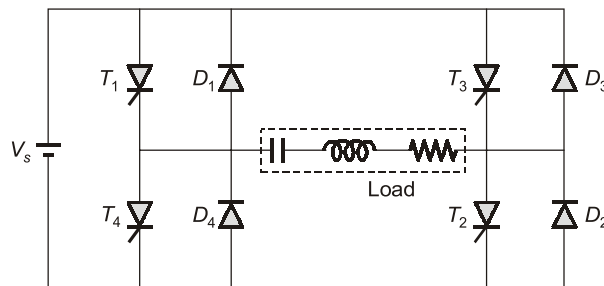

(a) Distortion factor,

$$g = \frac{\text{Fundamental RMS Voltage}}{\text{Total RMS Voltage}}$$

$$g = \frac{V_{o1}}{V_{or}}$$

For 1-phase full bridge,

$$V_{o1} = \frac{2\sqrt{2}}{\pi} V_s$$

$$V_{or} = V_s$$

$$\therefore g = \frac{2\sqrt{2}}{\pi} = 0.9$$

Total harmonic distortion,

$$\text{THD} = \sqrt{\frac{1}{g^2} - 1}$$

$$\text{THD} = 48.34\%$$

(b) For 1-phase full bridge

Fourier series of output voltage

$$V_o = \sum_{n=1,3,5}^{\infty} \frac{4V_s}{n\pi} \sin n\omega t$$

For RLC load

$$Z_n = R + j(X_{Cn} - X_{Ln})$$

$$|Z_n| = \sqrt{R^2 + (X_{Cn} - X_{Ln})^2}$$

$$\phi_n = \tan^{-1} \left(\frac{X_{Cn} - X_{Ln}}{R} \right)$$

Therefore, fourier series of load current

$$i_o = \sum_{n=1,3,5}^{\infty} \frac{4V_s}{n\pi |Z_n|} \sin(n\omega t - \phi_n)$$

(c) Distortion factor,

$$g = \frac{I_{o1}}{I_{or}}$$

$$n^{\text{th}} \text{ harmonic current, } I_{on} = \frac{4V_s}{n\pi Z_n} \sin(n\omega t - \phi_n)$$

$$\therefore I_{o1} = \frac{4V_s}{\pi Z_1} \sin(\omega t - \phi_1)$$

$$\text{Rms output current, } I_{or} = \sqrt{I_{o1}^2 + I_{o3}^2 + I_{o5}^2 + \dots}$$

$$g = \frac{I_{o1}}{I_{or}} = 0.988$$

$$\text{THD\%} = \left(\sqrt{\frac{1}{g^2} - 1} \right) \times 100 = 15.55\%$$

(d) Load power,

$$P = I_{or}^2 R$$

Considering only fundamental component of load current,

$$I_{or} = (I_{o1})_{\text{rms}}$$

$$(I_{o1})_{\text{rms}} = \frac{4V_s}{\pi Z_1} \times \frac{1}{\sqrt{2}}$$

$$= \frac{4 \times 220}{\pi \times \sqrt{\frac{1}{\omega C} - \omega L}} \times \frac{1}{\sqrt{2}}$$

$$= 19.402$$

$$P = I_{o1}^2 R = 2258.74 \text{ W}$$

Average DC source current,

$$I_s = \frac{1}{\pi} \int_0^{\pi} \sqrt{2} I_{o1} \sin(\omega t + 54^\circ) d\omega t$$

$$= 10.52 \text{ A}$$

(e) Conduction angle of diode,

$$\phi = \tan^{-1} \left(\frac{\frac{1}{\omega C} - \omega L}{R} \right)$$

$$= 54^\circ \text{ or } \frac{3}{10} \pi$$

Conduction time of diode,

$$\omega t_c = 54^\circ \text{ or } \frac{3}{10} \pi$$

$$t_c = 3 \text{ ms}$$

Conduction angle of transistor,

$$\pi - \phi = 126^\circ \text{ or } \frac{7}{10} \pi$$

Conduction time of transistor,

$$\omega t_c = 126^\circ \text{ or } \frac{7}{10} \pi$$

$$t_c = 7 \text{ ms}$$

(f)

$$(V_{o1})_{\text{rms}} = \frac{4V_s}{\sqrt{2} \times \pi} = 198.07 \text{ V}$$

$$(I_{o1})_{\text{rms}} = \frac{(V_{o1})_{\text{rms}}}{Z} = \frac{198.07}{\sqrt{k^2 + \left(\frac{1}{\omega C} - \omega L\right)^2}} = 19.402$$

$$\phi_1 = 54^\circ \text{ or } \frac{3}{10} \pi$$

$$(I_{T1})_{\text{peak}} = 19.402 \times \sqrt{2} = 27.44 \text{ A}$$

$$(I_{T1})_{\text{rms}} = \left[\frac{1}{2\pi} \int_0^{\frac{7}{10}\pi} (I_m \sin \omega t)^2 d(\omega t) \right]^{1/2}$$

$$= 12.66 \text{ A}$$

T3 : Solution

For 120° mode

$$V_L = \frac{V_S}{\sqrt{2}}$$

For Δ load :

$$V_{Ph} = V_L = \frac{V_S}{\sqrt{2}}$$

$$I_{Phase} = \frac{V_{Ph}}{r} = \frac{V_S}{\sqrt{2}r} = \frac{200}{\sqrt{2} \times 15}$$

$$P = 3I_{Phase}^2 r = 3 \times \left(\frac{200}{\sqrt{2} \times 15} \right)^2 \times 15 = 4 \text{ kW}$$

T4 : Solution

(d)

T5 : Solution

(d)

As $V_o < 0$, (Q_3 , D_3) and (Q_4 , D_4) should work.

Also

$$P = v_o i_o$$

As

$$I_o > 0$$

$$P < 0$$

Power is being feedback.

So, D_3 and D_4 are working.

T6 : Solution

$$V_a = V_{1m} \sin \omega t + V_{5m} \sin(5\omega t) + V_{7m} \sin(7\omega t)$$

$$V_b = V_{1m} \sin\left(\omega t - \frac{2\pi}{3}\right) + V_{5m} \sin 5\left(\omega t - \frac{2\pi}{3}\right) + V_{7m} \sin 7\left(\omega t - \frac{2\pi}{3}\right)$$

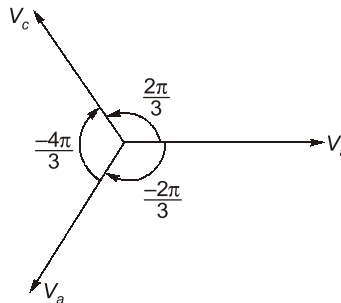

$$V_b = V_{1m} \sin\left(\omega t - \frac{2\pi}{3}\right) + V_{5m} \sin\left(5\omega t + \frac{2\pi}{3}\right) + V_{7m} \sin\left(7\omega t - \frac{2\pi}{3}\right)$$

T7 : Solution

(b)

- The circuit shown in the figure is a single phase bridge auto sequential commutated inverter (1-phase ASCI).
- Thyristor pairs T_1, T_2 and T_3, T_4 are alternatively switches to obtain a nearly square wave load current. Two commutating capacitors, one C_1 in the upper half and the other C_2 in the lower half are connected as shown.
- Diodes D_1 to D_4 are connected in series with each SCR to prevent the commutation capacitors from discharging into the load.

The inverter output frequency is controlled by adjusting the period T through the triggering circuits of thyristors.

The theoretical maximum output frequency obtainable

$$f_{\max} = \frac{1}{4RC} = \frac{1}{4 \times 10 \times 0.1 \times 10^{-6}} = 250 \text{ kHz}$$

T8 : Solution

(a)

Device used in current source inverter (CSI) must have reverse voltage blocking capacity. Therefore, devices such as GTOs, power transistors and power MOSFETs cannot be used in a CSI. So, a diode is added in series with the devices for reverse blocking.

T9 : Solution

(c)

$$\begin{aligned} V_S &= 600 \text{ V} \\ M_A &= 1 \\ \hat{V}_{L1} &= \sqrt{3} M_A \cdot \frac{V_S}{2} \\ V_{L1, \text{rms}} &= \left(\frac{\sqrt{3}}{2\sqrt{2}} \right) M_A V_S \\ &= \frac{\sqrt{3}}{2\sqrt{2}} \times 600 = 367.4 \text{ V} \end{aligned}$$

T10 : Solution

For $R = 2 \Omega$, $X_L = 8 \Omega$ and $X_C = 6 \Omega$, the fundamental component of load current lags the output voltage by 45° , this is shown in figure (b). The thyristor-current waveform i_{T1} and diode-current waveform i_{D1} are also shown in figure (b). It is observed from this figure that rms value of thyristor current is

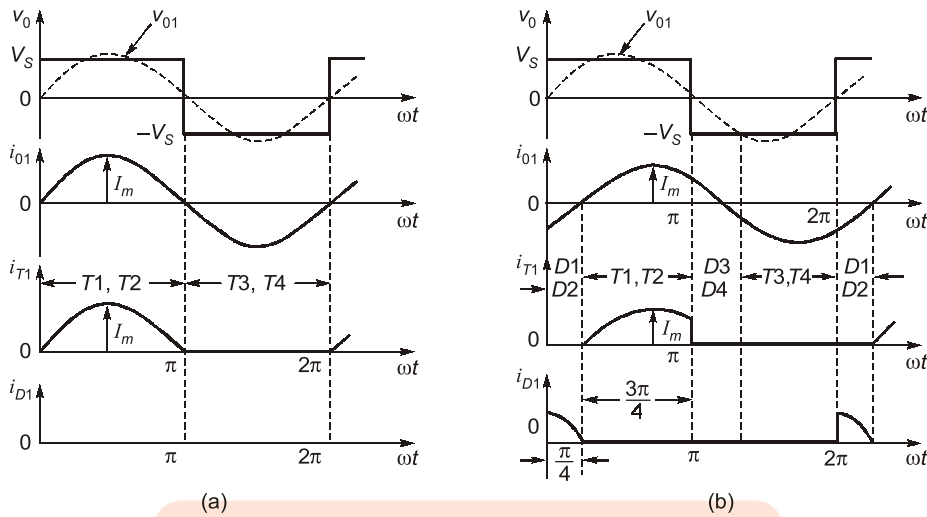

$$I_{T1} = \left[\frac{1}{2\pi} \int_0^{3\pi/4} (I_m \sin \omega t)^2 \cdot d(\omega t) \right]^{1/2}$$

$$= \frac{I_m}{2\sqrt{\pi}} \left[\omega t - \frac{\sin 2\omega t}{2} \right]_0^{3\pi/4} = 0.47675 I_m$$

$$= 0.47675 \times \sqrt{2} \times 81.317 = 54.818 \text{ A}$$

Rms value of diode current,

$$I_{D1} = \left[\frac{1}{2\pi} \int_0^{\pi/4} (I_m \sin \omega t)^2 \cdot d(\omega t) \right]^{1/2}$$

$$= 0.1507025 I_m = 0.1507025 \times \sqrt{2} \times 81.317 = 17.328 \text{ A}$$

As the load current i_0 does not change from positive to negative at an angle $\omega t < \pi$, no time is available for SCR to turn off; forced commutation is therefore essential.

T11 : Solution

$$V_{01} = 230 \text{ V}$$

$$\hat{V}_{01} = 230\sqrt{2}$$

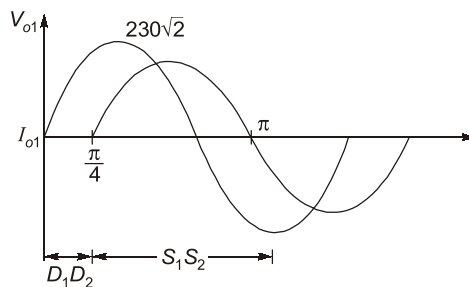

$$\hat{I}_{o1} = \frac{V_{o1}}{|Z_1|} = \frac{230\sqrt{2}}{\sqrt{R^2 + (X_L - X_C)^2}}$$

$$= \frac{230\sqrt{2}}{\sqrt{2^2 + (8-6)^2}} = 115 \text{ A}$$

$$\phi_1 = \tan^{-1}\left(\frac{X_L - X_C}{R}\right) = \tan^{-1}\left(\frac{8-6}{2}\right) = 45^\circ = \frac{\pi}{4}$$

$$i_{o1} = 115 \sin\left(\omega t - \frac{\pi}{4}\right)$$

$$I_{s1,\text{rms}} = \left\{ \frac{1}{2\pi} \int_{\pi/4}^{\pi} 115^2 \sin^2\left(\omega t - \frac{\pi}{4}\right) d\omega t \right\}^{\frac{1}{2}}$$

$$I_{s1,\text{rms}} = \left\{ \frac{1}{2\pi} \int_0^{3\pi/4} 115^2 \sin^2 \omega t d(\omega t) \right\}^{\frac{1}{2}} = 54.826 \text{ A}$$

T12 : Solution

Applying fourier series

$$a_n = 0$$

$$b_n = \frac{4V_s}{n\pi} [1 - \cos n\alpha_1 + \cos n\alpha_2]$$

To eliminate 3rd and 5th harmonic

$$b_3 = 1 - \cos 3\alpha_1 + \cos 3\alpha_2 = 0$$

$$b_5 = 1 - \cos 5\alpha_1 + \cos 5\alpha_2 = 0$$

$$\alpha_1 = 17.83^\circ$$

$$\alpha_2 = 37.96^\circ$$

T13 : Solution

(a) Rms output voltage,

$$V_{or} = V_s \left[\frac{2d}{\pi} \right]^{1/2}$$

$$= 141.42 \text{ V}$$

(b) Fourier series of output voltage waveform

$$V_o = \sum_{n=1,3,5}^{\infty} \frac{8V_s}{n\pi} \sin n\gamma \sin \frac{nd}{2} \sin n\omega t$$

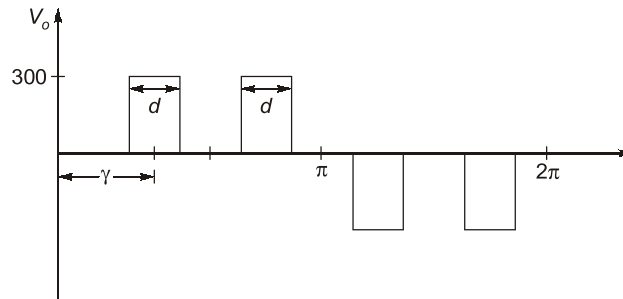

Peak value of 3rd harmonic,

$$\hat{V}_{o3} = \frac{8V_s}{3\pi} \sin(3 \times 45^\circ) \sin \frac{3 \times 20}{2}$$

$$\hat{V}_{o3} = 90.03 \text{ V}$$

(c) Rms value of fundamental voltage,

$$(V_{o1})_{\text{rms}} = \frac{8V_s}{\pi} \sin \gamma \sin \frac{d}{2} \frac{1}{\sqrt{2}}$$

$$(V_{o1})_{\text{rms}} = 66.328 \text{ V}$$

(d) 5th harmonic voltage,

$$V_{o5} = \frac{8V_s}{5\pi} \sin(5 \times 45^\circ) \sin \frac{5 \times 20}{2}$$

$$= -82.76$$

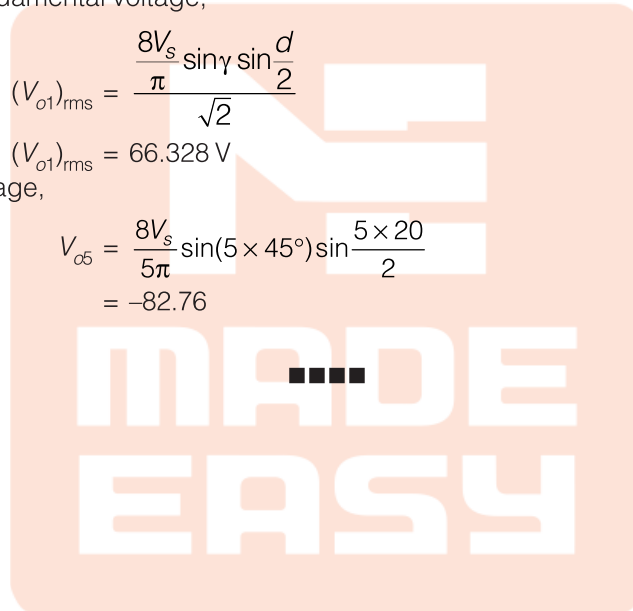

5

Resonant Converters and Power Electronics Applications (Drives & SMPS)



Detailed Explanation of Try Yourself Questions

T1 : Solution

At $t = 0$, steady state exists and therefore, generated torque = load torque

$$T_e = T_L$$

In general, the dynamic equation for the motor load combination is
generated torque = inertia torque + friction torque + load torque

$$T_e = J \frac{d\omega_m}{dt} + D\omega_m + T_L$$

As friction torque is zero,

$$D\omega_m = 0$$

The differential equation, governing the speed of the drive at $t > 0$,

$$T_e = J \frac{d\omega_m}{dt} + T_L$$

$$100 = 0.01 \frac{d\omega_m}{dt} + 40 \quad \dots(i)$$

$$\frac{d\omega_m}{dt} = 6000$$

$$dt = \frac{d\omega_m}{6000}$$

Its integration gives, $t = \frac{\omega_m}{6000} + A \quad \dots(ii)$

Initial speed at $t = 0^+$ remains 500 rpm. Therefore,

$$\omega_{m0} = \frac{2\pi \times 500}{60} = \frac{100\pi}{6} \text{ rad/sec}$$

Substituting this value in equation (ii),

$$0 = \frac{1}{6000} \times \frac{100\pi}{6} + A \quad \text{or} \quad A = \frac{-\pi}{360}$$

$$t = \frac{\omega_m}{6000} - \frac{\pi}{360}$$

Final speed,
$$\omega_m = \frac{2\pi \times 1000}{60} = \frac{200\pi}{6} \text{ rad/sec}$$

$$t = \frac{200\pi}{6000 \times 6} - \frac{\pi}{360} = \frac{\pi}{360} \text{ sec} = 0.0873 \text{ sec}$$

\therefore Time taken for the speed to reach 1000 rpm = 0.0873 sec \approx 87.3 msec

T2 : Solution

(a)

T3 : Solution

(c)

T4 : Solution

(a)

$V_s = 400 \text{ V}$
 $R_a = 0.2 \ \Omega$
 $K_m = 1.2 \text{ V-s/rad}$
 $I_o = 300 \text{ A (constant)}$
 $N_{\min} = ?, N_{\max} = ?$
 $E_b = V_o + I_o R_a$

$$[V_o = (1 - \alpha)V_s]$$

$$\left[E_b = K_m \omega = K_m \frac{2\pi}{60} N \right]$$

$$K_m \frac{2\pi}{60} N = V_o + I_o R_a$$

$$K_m \frac{2\pi}{60} N_{\min} = (V_o)_{\min} + I_o R_a$$

$$K_m \frac{2\pi}{60} N_{\min} = 0 + I_o R_a$$

$$\frac{1.2 \times 2\pi}{60} N_{\min} = 300 \times 0.2$$

$$N_{\min} = 477 \text{ rpm}$$

Similarly,

$$K_m \frac{2\pi}{60} N_{\max} = V_o + I_o R_a$$

$$K_m \frac{2\pi}{60} N_{\max} = V_s + I_o R_a$$

$$1.2 \times \frac{2\pi}{60} N_{\max} = 400 + 300 \times 0.2$$

$$N_{\max} = 3660 \text{ rpm}$$

T5 : Solution

$$N_{S1} = 3000 \text{ rpm} \quad (\text{synchronous speed at 50 Hz})$$

$$N_1 = 2850 \text{ rpm} \quad (\text{motor speed at 50 Hz})$$

$$S_{FL} = \frac{3000 - 2850}{3000} = 0.05 \quad (\text{rated slip at 50 Hz})$$

where, by (V/f) control,

$$N_{S2} = 3000 \left(\frac{40}{50} \right) = 2400 \text{ rpm} \quad (\text{synchronous speed at 40 Hz})$$

∴

N_2 = New running speed of motor

$$N_{s2} \left(1 - \frac{S_{FL}}{2} \right) = 2400 \left(1 - \frac{0.05}{2} \right) = 2340 \text{ rpm}$$

T6 : Solution

(a)

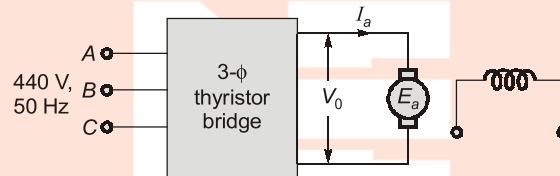

For a separately excited DC motor

$$\text{Back emf} = E_a = V_0 - I_a R_a$$

Since, losses are neglected R_a can be neglected

So,

$$E_a \approx V_0$$

$$V_0 = E_a = k_a \phi N$$

$$V_0 \propto N$$

...(i)

At rated voltage $V_0 = 440 \text{ V}$ and $N = 1500 \text{ rpm}$ so, at half the rated speed. $\left(\frac{N}{2} = 750 \text{ rpm} \right)$ output voltage of the bridge (V_0) is 220 V.

If I_a is the average value of armature current rms value of supply current will be

$$I_s = I_a \sqrt{\frac{2}{3}}$$

Power delivered to the motor

$$P_0 = V_0 I_a$$

Input VA to the thyristor bridge

$$S_{in} = \sqrt{3} V_s I_s$$

Input power factor

$$= \frac{P_0}{S_{in}} = \frac{V_0 I_a}{\sqrt{3} V_s I_s} = \frac{220 \times I_a}{\sqrt{3} \times 440 \times I_a \sqrt{\frac{2}{3}}} = 0.354$$

T7 : Solution

(4.98)

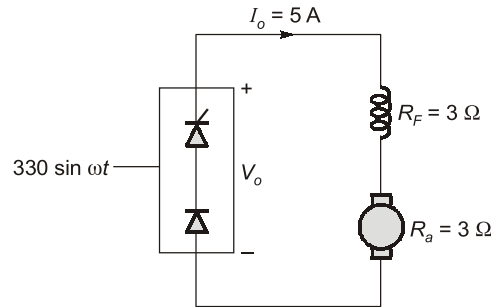

$$\alpha = 45^\circ$$

$$N = 1450 \text{ rpm}$$

$$T_a \propto \phi I_a$$

$$T_a = K_m I_o$$

(If flux is constant)

$$E_b = K_m \omega = K_m \frac{2\pi}{60} N$$

$$V_o = E_b + I_a(R_a + R_F)$$

$$\frac{V_m}{\pi}(1 + \cos \alpha) = K_m \frac{2\pi}{60} N + 5(3 + 3)$$

$$\frac{330}{\pi}(1 + \cos 45^\circ) = K_m \frac{2\pi}{60} \times 1456 + 5 \times (3 + 3)$$

$$K_m = 0.98 \text{ V-s/rad}$$

$$T = 0.98 \times 5 = 4.9 \text{ Nm}$$

T8 : Solution

At rated torque,

$$I_o = 100 \text{ A}$$

$$V_o = E_b + I_o R_a$$

$$V_o = K_m \frac{2\pi}{60} \cdot N + I_o R_a$$

$$220 = K_m \frac{2\pi}{60} \times 2100 + 100 \times 0.1$$

$$K_m = 0.955$$

$$V_o = E_b + I_o R_a$$

$$\alpha V_s = k_m \cdot \frac{2\pi}{60} N + I_o R_a$$

$$0.4 \times 250 = 0.955 \times \frac{2\pi}{60} N + 100 \times 0.1$$

$$N = 900 \text{ rpm}$$

T9 : Solution

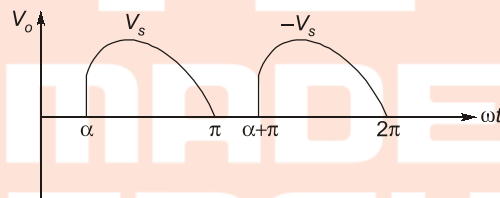
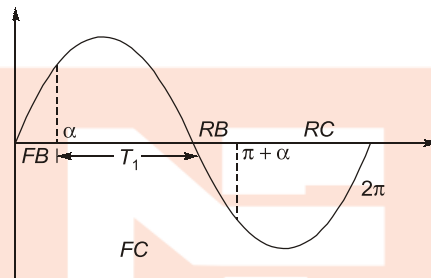
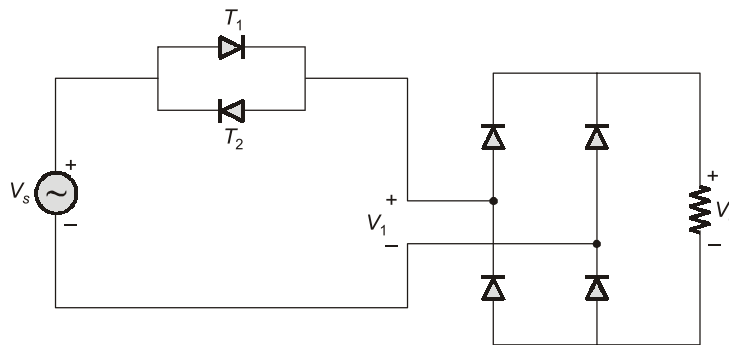

$$V_{or} = \frac{V_m}{\sqrt{2\pi}} \left\{ (\pi - \alpha) + \frac{1}{2} \sin 2\alpha \right\}^{\frac{1}{2}}$$

$$V_{or} = \frac{V_m}{2}$$

∴

$$I_{or} = \frac{V_{or}}{R} = \frac{V_m}{2R} = \frac{200\sqrt{2}}{2 \times \frac{10}{\sqrt{2}}} = 20 \text{ A}$$

