

ESE

GATE

State Engg. Exams

MADE EASY
WORKBOOK 2027



**Detailed Explanations of
Try Yourself *Questions***

Electrical Engineering
Electrical Circuits





Detailed Explanation of Try Yourself Questions

T1. (b)

Writing node equation at the top center node

$$\frac{V_1 - 0}{2 + 3} + \frac{(V_1 - 1)}{1} + \frac{V_1 - \alpha V_x}{5} = 0$$

$$\frac{V_1}{5} + \frac{V_1 - 1}{1} + \frac{V_1 - \alpha V_x}{5} = 0 \quad \dots(i)$$

Since

$$V_x = \left(\frac{2}{2+3} \right) V_1 = \frac{2}{5} V_1 \quad (\text{Voltage Division})$$

Now, by substituting

$V_1 = (5/2) V_x$ into equation (1), we get

$$\frac{1}{5} \left(\frac{5}{2} V_x \right) + \left(\frac{5}{2} V_x - 1 \right) + \frac{1}{5} \left(\frac{5}{2} V_x - V_x \right) = 0$$

$$\frac{V_x}{2} + \frac{5}{2} V_x + \frac{V_x}{2} = 1$$

$$\frac{7}{2} V_x - \alpha + \frac{V_x}{5} = 1$$

$$35 V_x - 2 \alpha V_x = 10$$

$$V_x = \frac{10}{(35 - 2\alpha)}$$

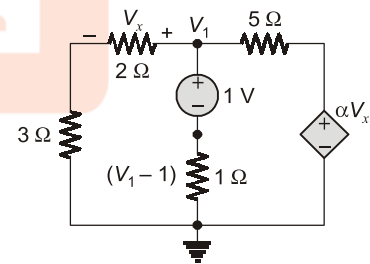

T2. Sol.

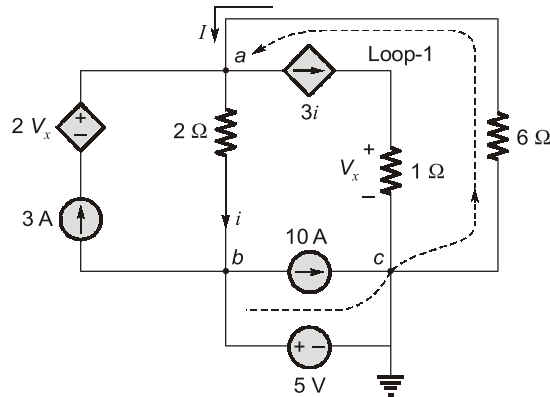

Taking node 'C' as reference,
KCL at node 'a':

$$I + 3 = 3i + i$$

$$I = 4i - 3 \quad \dots(i)$$

KVL in loop-1

$$2i + 5 + 6I = 0$$

$$6I = -2i - 5 \quad \dots(ii)$$

Solving equation (i) and (ii), we get

$$I = -1 \text{ A}, \quad i = \frac{1}{2} \text{ A}$$

$$i = 0.5 \text{ A}$$

T3. Sol.

Transform Δ to Y the circuit can be reduced as below,

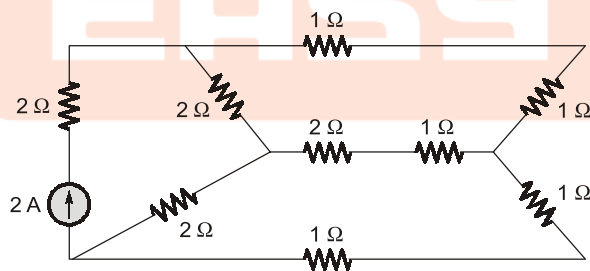

From balanced bridge
Network can be reduced to

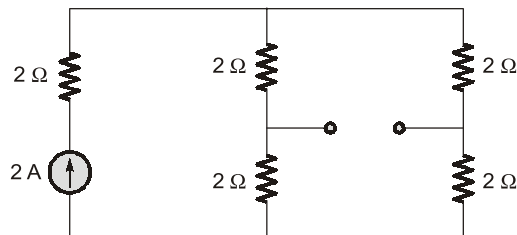

Total resistance across current source,

$$R_{eq} = 2 + \frac{4 \times 4}{4 + 4} = 4 \Omega$$

Power delivered by current source, $P = I^2 R_{eq} = 2^2 \times 4 = 16 \text{ W}$

T4. (b)

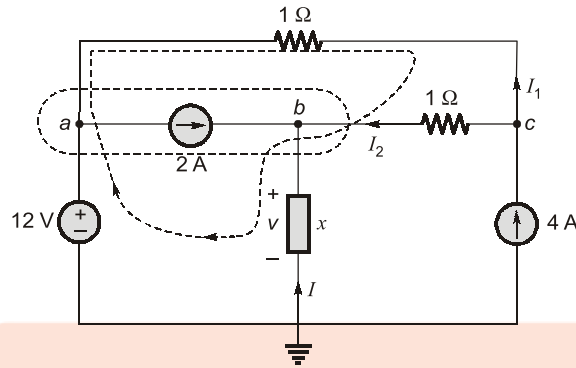

At node C;

$$V = AI + B \tag{... (i)}$$

KVL in loop-1,

$$4 = I_1 + I_2 \tag{... (ii)}$$

$$\begin{aligned} -12 - I_1 + I_2 + V &= 0 \\ V - I_1 + I_2 &= 12 \end{aligned} \tag{... (iii)}$$

KCL at node (b),

$$2 + I + I_2 = 0 \tag{... (iv)}$$

From equation (ii) and (iii),

$$I_1 = 4 - I_2$$

and

$$\begin{aligned} V + I_2 - 4 + I_2 &= 12 \\ 2I_2 &= 12 - V + 4 \end{aligned} \tag{... (v)}$$

From equation (iv) and (v),

$$2 + I + 6 - \frac{V}{2} + 2 = 0$$

$$10 + I - \frac{V}{2} = 0$$

$$V = 2I + 20$$

$$A = 2, B = 20$$

T5. (c)

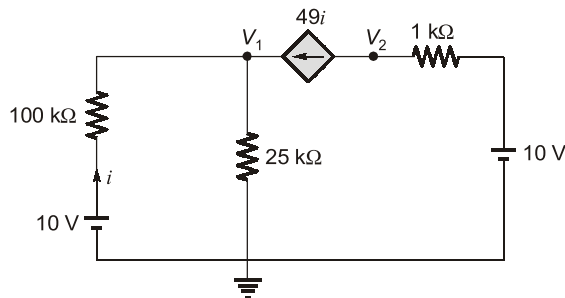

KCL at node V_1 ,

$$i + 49i = \frac{V_1}{25}$$

$$50i = \frac{V_1}{25} \quad \dots(i)$$

$$i = \frac{10 - V_1}{100K} \quad \dots(ii)$$

From equation (i) and (ii),

$$50 \times \frac{10 - V_1}{100K} = \frac{V_1}{25}$$

$$\Rightarrow \frac{1}{2K}(10 - V_1) = \frac{V_1}{25}$$

$$\Rightarrow 10 - V_1 = \frac{(2K) \cdot V_1}{25}$$

$$10 = 81 V_1$$

$$\Rightarrow V_1 = \frac{10}{81} \text{ volts}$$

$$\text{and } i = \frac{10 - \frac{10}{81}}{(100 K)}$$

$$V_2 = 10 - 1K \times \frac{\left(10 - \frac{10}{81}\right)}{100 K} \times 49$$

$$= 5.16 \text{ volts}$$

T6. (a)

Transform current source to voltage source,
Applying KCL, at node V_1 ,

$$\frac{V_1 + 8}{8} + \frac{V_1 - 14}{8} + \frac{V_1 - 1}{4} = 0$$

$$V_1 = 2 \text{ V}$$

Current,

$$i = \frac{V_1 - 1}{4} = \frac{1}{4} \text{ A}$$

then,

$$V_0 = \frac{1}{4} \times 4 = 1 \text{ V}$$

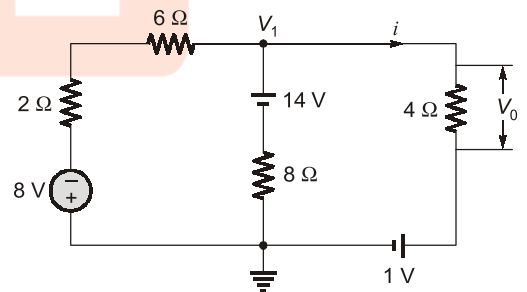

T7. (a)

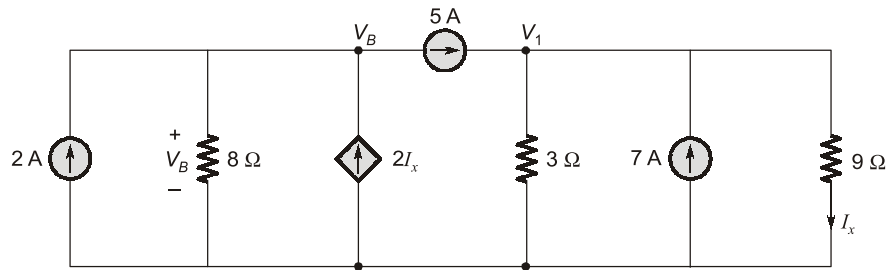

By KCL at node 1,

$$\frac{V_1}{3} + \frac{V_1}{9} = 5 + 7$$

$$V_1 = 27 \text{ V}$$

$$I_x = \frac{V_1}{9} = \frac{27}{9} = 3 \text{ A}$$

By KCL at node B,

$$2 + 2I_x = \frac{V_B}{8} + 5$$

$$2 + 2(3) = \frac{V_B}{8} + 5$$

⇒

$$V_B = 24 \text{ V}$$

MADE
EASY

2

Steady State AC Analysis



Detailed Explanation of Try Yourself Questions

T1. Sol.

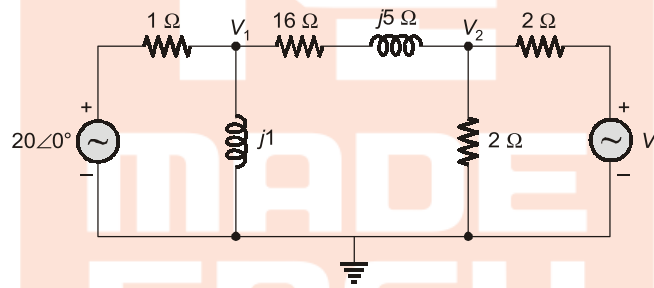

From given data current in 16Ω is equal to zero, hence

$$V_1 = V_2$$

$$V_1 = 20\angle 0^\circ \times \frac{j1}{1+j1} = 20 \frac{1\angle 90^\circ}{\sqrt{2}\angle 45^\circ} = \frac{20}{\sqrt{2}} \angle 45^\circ$$

$$V_1 = V_2 = \frac{20}{\sqrt{2}} \angle 45^\circ$$

$$V_s = 2 V_2 = 2 \frac{20}{\sqrt{2}} \angle 45^\circ = 20\sqrt{2} \angle 45^\circ \text{ V}$$

T2. (b)

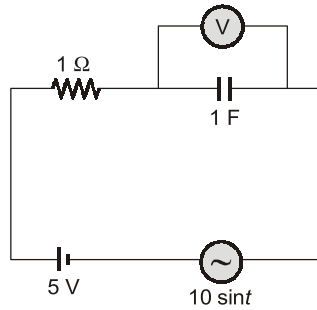

∴ $X_C = \frac{1}{\omega C} = \frac{1}{1 \times 1}$
 $X_C = 1 \Omega$

using superposition principle,

- (i) For 5 V source
In steady-state,

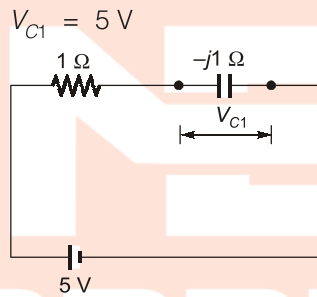

- (ii) For 10 sin t source:

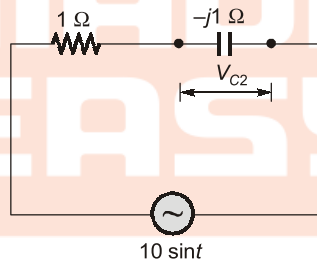

$$V_{C2} = \frac{10}{\sqrt{2} \times \sqrt{2}} \times 1 = 5 \text{ V}$$

Now,

$$V_C = \sqrt{V_{C1}^2 + V_{C2}^2} = \sqrt{5^2 + (5)^2} = \sqrt{50} = 7.07 \text{ V}$$

T3. (c)

$$I = 4.24 \sin(500t + 45^\circ)$$

$$P = 180 \text{ W, p.f.} = 0.8 \text{ lag}$$

∴ Power dissipated in resistor = $P = I_{Or}^2 \times R$

$$180 = \left(\frac{4.24}{\sqrt{2}} \right)^2 \times R$$

$$R = 20.02 \approx 20 \Omega$$

T4. (a)

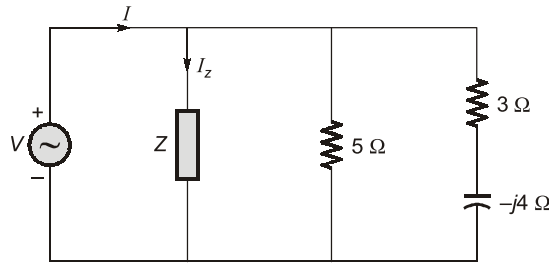

$$V = 50\angle 30^\circ$$

$$I = 27.9\angle 57.8^\circ$$

$$Z_{eq} = \frac{V}{I} = \frac{50\angle 30^\circ}{27.9\angle 57.8^\circ} = 1.8\angle -27.8^\circ \Omega$$

$$= 1.8\angle -27.8^\circ \Omega$$

∴

$$\frac{1}{Z_{eq}} = \frac{1}{Z} + \frac{1}{5} + \frac{1}{3-j4}$$

$$\frac{1}{1.8\angle 27.8} = \frac{1}{Z} + \frac{1}{5} + \frac{3+j4}{25}$$

$$\frac{1}{Z} = \frac{1}{1.8\angle -27.8} - \frac{1}{5} - \frac{3+j4}{25}$$

$$Z = 5\angle -30^\circ \Omega$$

T5. Sol.

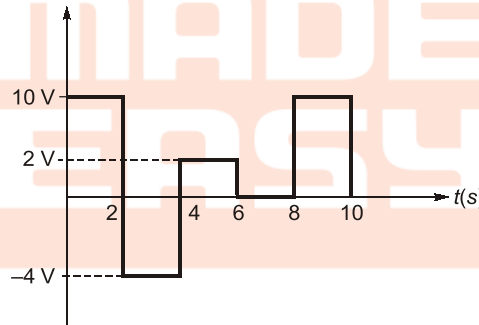

$$\text{Rms value} = \left[\frac{1}{T} \int_0^T f^2(t) d(t) \right]^{1/2} = \left[\frac{1}{10} \int_0^{10} f^2(t) \cdot d(t) \right]^{1/2}$$

$$= \left[\frac{1}{10} \left\{ \int_0^2 100 dt + \int_2^4 16 dt + \int_4^6 4 dt + \int_6^8 0 + \int_8^{10} 100 dt \right\} \right]^{1/2}$$

$$= \left[\frac{1}{10} \{ 100 \times 2 + 16 \times 2 + 4 \times 2 + 100 \times 2 \} \right]^{1/2}$$

$$= \left[\frac{1}{10} (440) \right]^{1/2} = \sqrt{44} = 6.633 \text{ unit}$$

T6. (c)

Given redundant network can be reduced as,

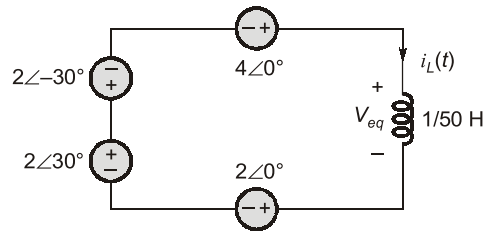

$$X_L = \omega L = 100 \left(\frac{1}{50} \right) = 2$$

$$i_L(t) = \frac{V_{eq}}{jX_L}$$

$$i_L(t) = \frac{2 + j2}{j2} = \sqrt{2} \angle -45^\circ$$

$$i_L(t) = 1.414 \cos(100t - 45^\circ) \text{ A}$$

T7. (a)

Current,

$$i(t) = C \frac{dv(t)}{dt}$$

For

$$0 < t < 0.5 \text{ s, } v(t) = 30t^2 \text{ V}$$

$$i(t) = 20 \times 10^{-6} (60t) = 1.2t \text{ mA}$$

For

$$0.5 \text{ s} < t < 1 \text{ s, } v(t) = 30(t-1)^2$$

$$i(t) = (20 \times 10^{-6}) [60(t-1)] = 1.2(t-1) \text{ mA}$$

■ ■ ■ ■

3

Transient Response



Detailed Explanation of Try Yourself Questions

T1. (c)

For the given circuit,

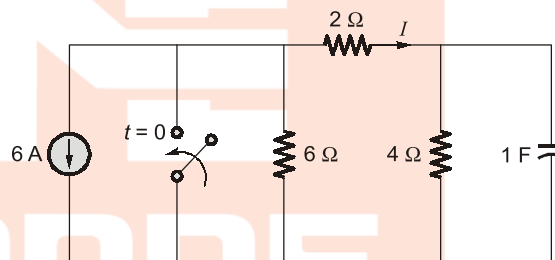

For $t < 0$; at

Steady-state:

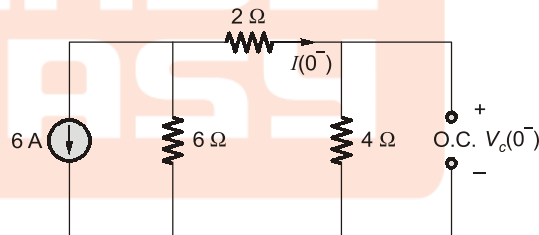

$$I(0^-) = -\frac{6}{12} \times 6 = -3 \text{ A}$$

and

$$V_c(0^-) = -12 \text{ V}$$

after closing switch at $t = 0^+$, the circuit reduced as:

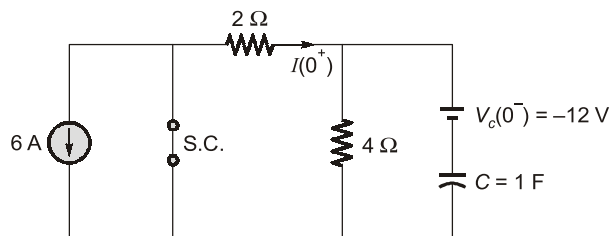

$$I(0^+) = \frac{12}{2} = 6 \text{ A}$$

T2. (c)

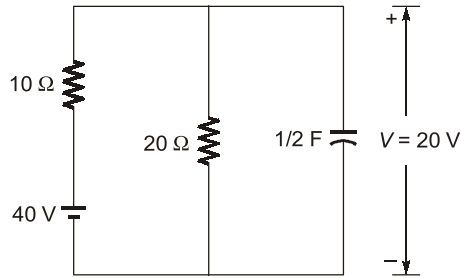

Suppose at time $t = 0$, the voltage ' $V = 20\text{ V}$
The circuit can be reduced as

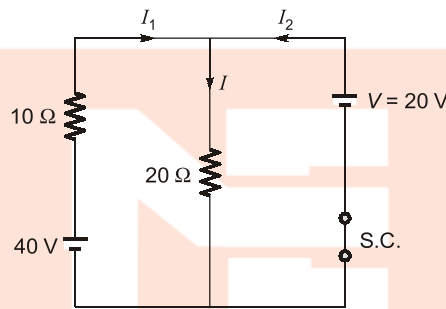

at $t = 0^+$;

$\therefore I = \frac{20}{20} = 1\text{ A}$

and

$I_1 = \frac{40 - 20}{10} = 2\text{ A}$

$I_2 = -1\text{ A}$

\therefore Current flowing across capacitor at $t = 0^+$;

$$C \frac{dV}{dt} \Big|_{t=0^+} = -I_2 \text{ or } \left| \frac{dV}{dt} \right|_{\text{at } t=0^+} = 2\text{ V/s}$$

T3. Sol.

From given data,

$$i(0^+) = \frac{\Psi(0^+)}{L} = \frac{10}{1} = 10\text{ A}$$

at $t = \infty$;

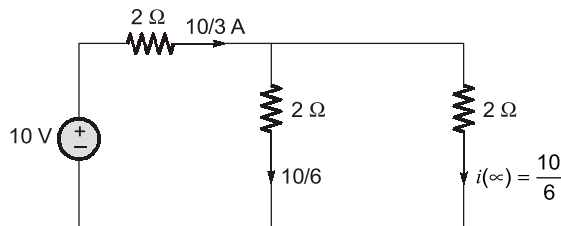

$$i(t) = [i(0^+) - i(\infty)] e^{-Rt/L} + i(\infty)$$

$$i(t) = \left[10 - \frac{10}{6} \right] e^{-\frac{3t}{1}} + \frac{10}{6} = [1.67 + (8.333) e^{-3t}] \text{A.}$$

T4. (c)

∴ At $t < 0$; the circuit is behaving as shown in figure,

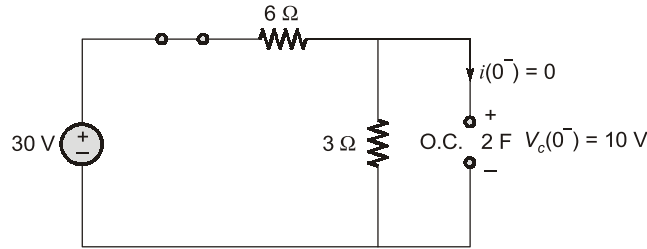

$$i(0^-) = 0; \quad V_c(0^-) = 10 \text{ V}$$

At $t > 0$; now here we can find,

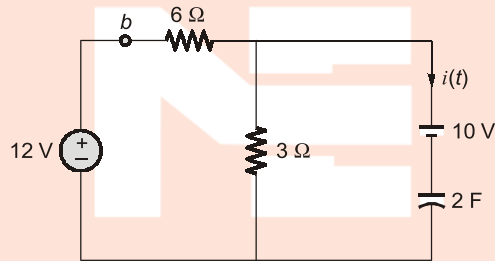

$$i(\infty) = 0$$

$$V_c(\infty) = 4 \text{ V}$$

$$V_c(t) = V_c(\infty) + [V(0^+) - V(\infty)] e^{-t/\tau}$$

$$\tau = R_{eq} \cdot C = (6 \parallel 3) \times 2$$

$$= 2 \times 2 = 4 \text{ sec}$$

$$V_c(t) = 4 + [10 - 4] e^{-t/4} = 4 + 6e^{-t/4}$$

$$i_c(t) = -C \frac{dV}{dt} = -C \times \left[\frac{d[4 + 6e^{-t/4}]}{dt} \right]$$

$$= -2 \times \frac{6}{4} \cdot e^{-t/4} = -3e^{-t/4} \text{ A}$$

and

Here,

T5. (b)

At $t = 0^-$

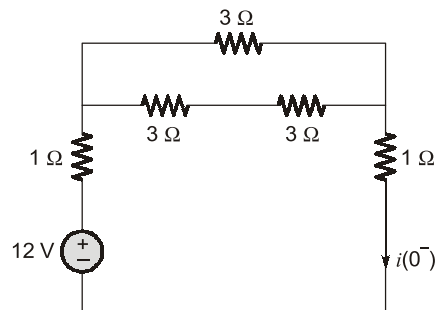

$$i(0^-) = \frac{12}{R_{eq}} = \frac{12}{4} = 3 \text{ A}$$

$$i(0^+) = i(0^-) = 3 \text{ A}$$

At $t = \infty$;
Transform Δ to Y;

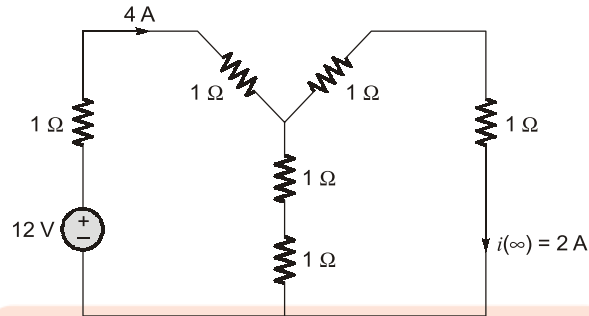

$$i(\infty) = 2 \text{ A}$$

$$i(t) = [(i(0^+) - i(\infty))e^{-\frac{Rt}{L}} + i(\infty)]$$

$$i(t) = (3 - 2)e^{-3t} + 2$$

$$i(t) = (2 + e^{-3t})\text{A}$$

T6. Sol.

$$F(s) = \frac{4e^{-2s(s+2)}}{s}$$

$$\text{Initial value} = \lim_{s \rightarrow \infty} s \cdot F(s)$$

$$f(0) = \lim_{s \rightarrow \infty} \frac{s \times 4e^{-2s}(s+2)}{s} = \lim_{s \rightarrow \infty} 4e^{-2s}(s+2)$$

$$= \lim_{s \rightarrow \infty} \frac{4(s+2)}{\left[1 + 2s + \frac{(2s)^2}{2!} + \frac{(2s)^3}{3!} + \dots\right]}$$

$$= \lim_{s \rightarrow \infty} \frac{4s \left[1 + \frac{2}{s}\right]}{s \left[\frac{1}{s} + 2 + \frac{2^2 s}{2!} + \frac{2^3 s^2}{3!} + \dots\right]}$$

$$= \frac{4[1+0]}{[0+2+\infty+\infty+\dots+\infty]} = \frac{4}{\infty} = 0$$

Final value,

$$\begin{aligned} f(\infty) &= \lim_{s \rightarrow 0} s \cdot F(s) = \lim_{s \rightarrow 0} \frac{s \times 4e^{-2s} \cdot (s+2)}{s} \\ &= 4e^{-2 \times 0} (0 + 2) = 8e^0 = 8(1) \\ &= 8 \end{aligned}$$

T7. (d)

The series connected capacitors can be replaced with an equivalent capacitor as shown

$$v_o(0) = 20 \text{ V}$$

$$C_{eq} = \frac{(30)(45)}{30 + 45} = 18 \mu F$$

$$v_o(t) = v_o(0) + \frac{1}{C_{eq}} \int_0^t i(t) dt$$

-ve sign is taken because current flows from -ve to +ve polarity.

$$v_o(t) = 20 - \frac{1}{C_{eq}} \int_0^t i(t) dt$$

$$= 20 - \frac{1}{18 \times 10^{-6}} \int_0^t i(900 \times 10^{-6}) e^{-2.5t} dt$$

$$= 20 - \frac{900 \times 10^{-6}}{18 \times 10^{-6}} \left[\frac{e^{-2.5t}}{-2.5} \right]_0^t$$

$$= 20 + 20 [e^{-2.5t} - 1] = 20 e^{-2.5t} \text{ V}$$

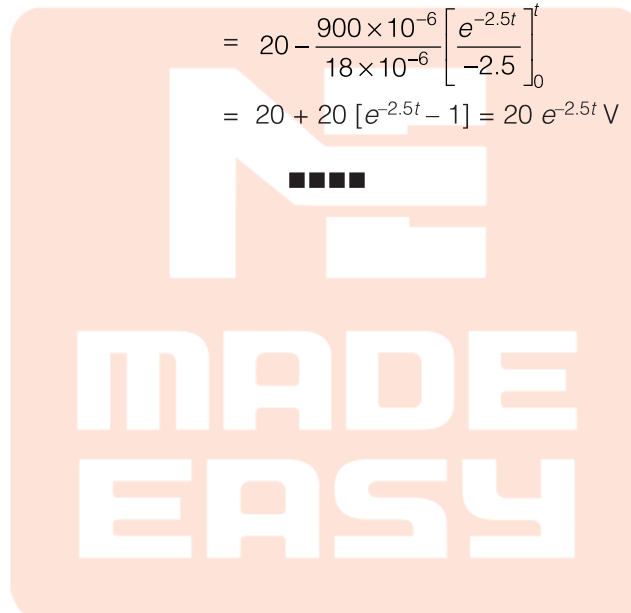
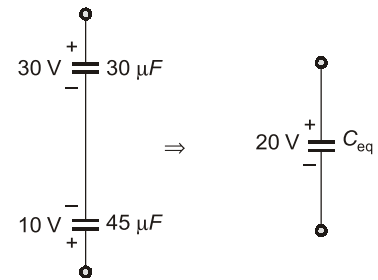

4

Graph Theory



Detailed Explanation of Try Yourself Questions

T1. (c)

T2. (d)

Dual of the given network is

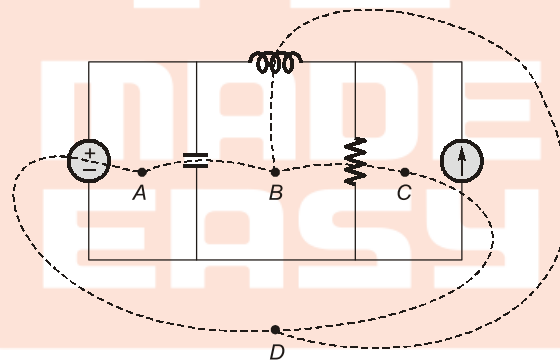

⇓ Dual network

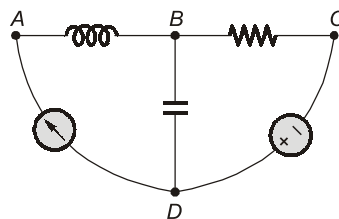

5

Network Theorems



Detailed Explanation of Try Yourself Questions

T1. (d)

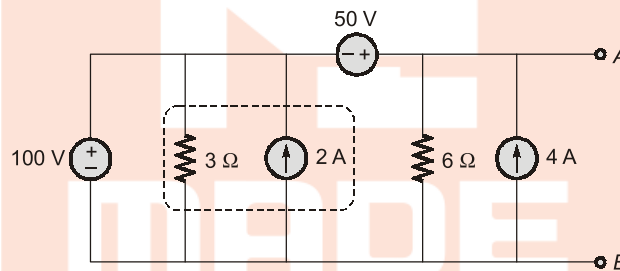

For R_{AB} :

$$V_{AB} = 50 + 100 = 150 \text{ V}$$

$$R_{AB} = 0$$

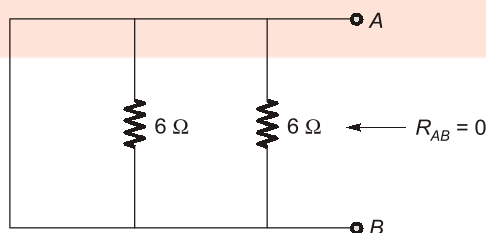

then here,

$$I_N = \frac{V_{AB}}{R_{AB}} = \infty$$

Therefore, norton's equivalent circuit between terminals A and B does not exist.

T2. (a)

$$Z_S = \frac{R(j\omega L)}{R + j\omega L}$$

To separate real and imaginary,

$$Z_S = \frac{R(j\omega L)}{R + j\omega L} \times \frac{R - j\omega L}{R - j\omega L} = \frac{R\omega^2 L^2}{R^2 + \omega^2 L^2} + j \frac{R^2 \omega L}{R^2 + \omega^2 L^2}$$

From maximum power theorems,

$$Z_L = Z_S^*$$

$$R_1 - j \frac{1}{\omega C} = \frac{R\omega^2 L^2}{R^2 + \omega^2 L^2} - j \frac{R^2 \omega L}{R^2 + \omega^2 L^2}$$

Compare real and imaginary part on both sides

$$R_1 = \frac{R\omega^2 L^2}{R^2 + \omega^2 L^2}$$

$$C = \frac{R^2 + \omega^2 L^2}{R^2 \omega^2 L}$$

T3. Sol.

Case-1: To find (Z_{th})

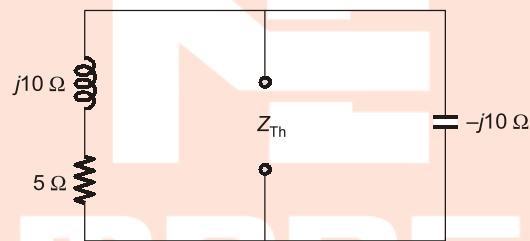

$$Z_{th} = \frac{(5 + j10)(-j10)}{5 + 10 - j10} = 20 - j10 \Omega$$

Case-2: To find (V_{th})

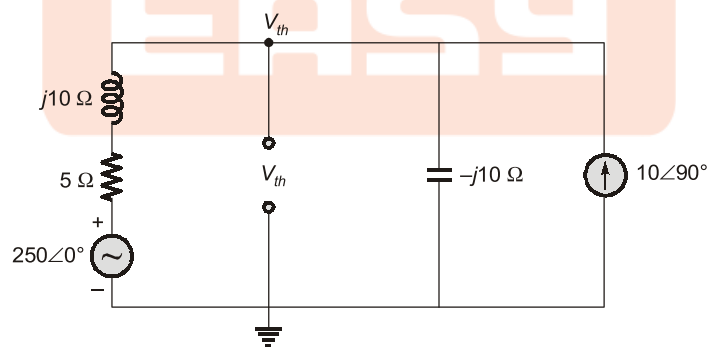

$$\frac{V_{th} - 250}{5 + j10} + \frac{V_{th}}{-j10} = 10 \angle 90^\circ$$

$$V_{th} = (100 - j300) \text{ V}$$

From maximum power theorem,

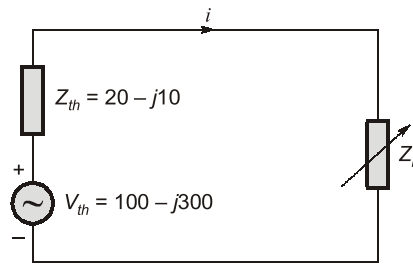

$$Z_L = Z_{th}^*$$

$$Z_L = 20 + j10$$

Current,

$$i = \frac{\sqrt{100^2 + 300^2}}{40}$$

$$P_L = i^2 R_L = i^2 \times 20 = 1250 \text{ W}$$

T4. (c)

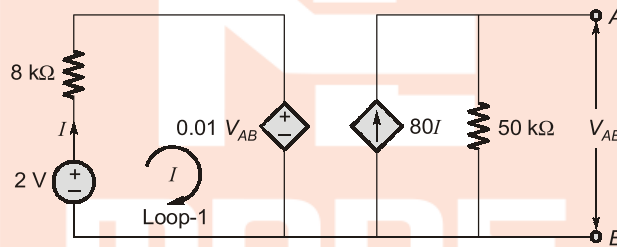

$$V_{AB} = V_{Th} = 50 \text{ K} \times 80I \quad \dots(i)$$

KVL in loop-1,

$$-2 + (8 \times I) \times 10^3 + 0.01 \times V_{AB} = 0$$

$$2 = 10^3 [8I + 0.01 \times 50 \times 80I]$$

$$2 = 10^3 [8I + 40I]$$

$$2 = 48I \times 10^3$$

⇒

$$I = \frac{2}{48K} \quad \dots(ii)$$

Now,

$$V_{Th} = 50K \times 80 \times \frac{2}{48K} = 166.67 \text{ V}$$

T5. (b)

From the given network,

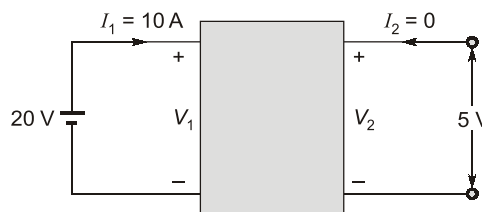

$$\begin{aligned} \therefore I_2 &= 0 \\ Z_{11} &= \frac{V_1}{I_1} = \frac{20}{10} = 2 \Omega \\ Z_{21} &= \frac{V_2}{I_1} = \frac{5}{10} = 0.5 \Omega \end{aligned}$$

For a reciprocal network,

$$Z_{12} = Z_{21} = 0.5$$

\therefore For the given second network,

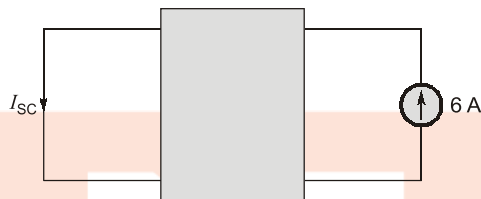

$$\begin{aligned} \therefore I_{SC} &= I_1, \quad I_2 = 6 \text{ A} \\ \therefore \frac{I_1}{I_2} &= \frac{Z_{12}}{Z_{11}} = \frac{V_1/I_2}{V_1/I_1} = \frac{0.5}{2} = \frac{1}{4} \\ \therefore I_{SC} &= I_1 = \frac{6}{4} = 1.5 \text{ A} \end{aligned}$$

T6. (c)

Combining the parallel resistance and adding the parallel connected current sources.

$$\begin{aligned} 9 \text{ A} - 3 \text{ A} &= 6 \text{ A (upward)} \\ 3 \Omega \parallel 6 \Omega &= 2 \Omega \end{aligned}$$

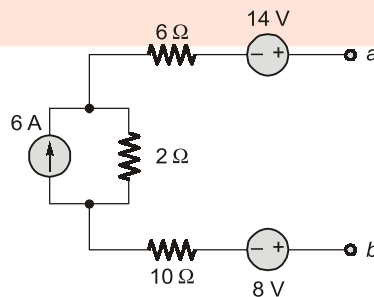

Source transformation of 6 A source

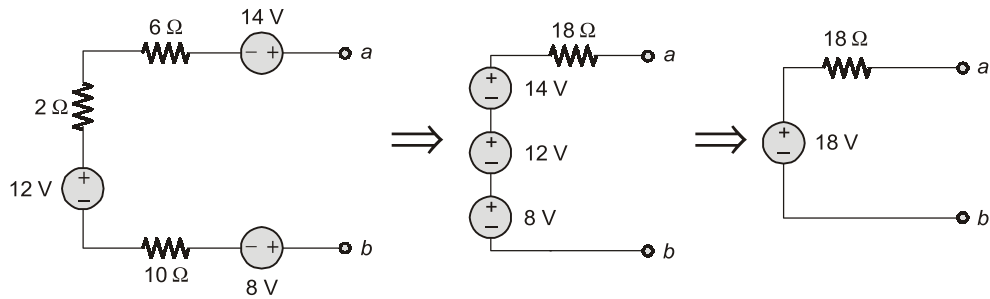

T7. (d)

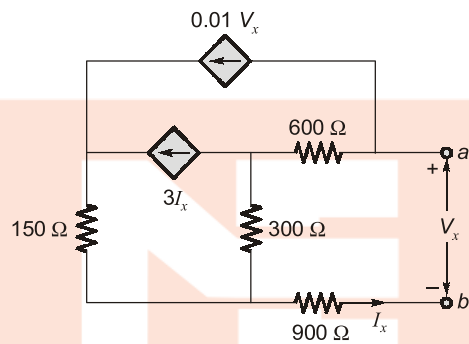

For V_{OC} across a and b ,
 $\therefore I_x = 0$; as O.C.

Now, circuit is reduced as below,

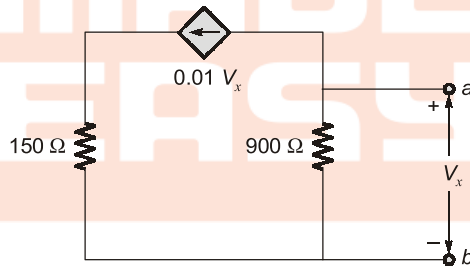

$$V_x = -900 \times 0.01 V_x$$

Only one case is possible,
i.e.

$$V_{OC} = 0 \text{ V}$$

For R_{Th} :

$$R_{Th} = \frac{V_x}{I_x}$$

$$V_x = 1 \text{ V}$$

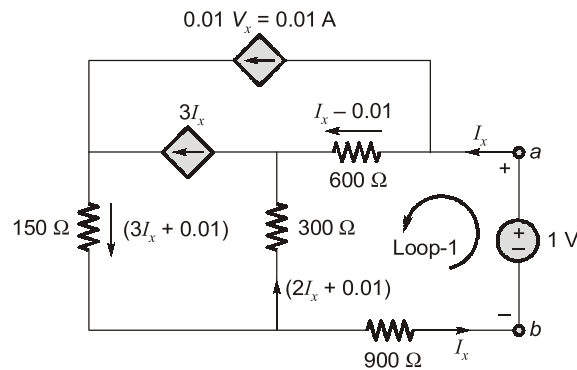

KVL in loop-1,

$$1 = 600(I_x - 0.01) - 300(2I_x + 0.01) + 900I_x$$

$$1 = 600I_x - 6 - 600I_x - 3 + 900I_x$$

$$10 = 900I_x$$

⇒

$$I_x = \frac{1}{90}$$

$$R_{Th} = 90 \Omega$$

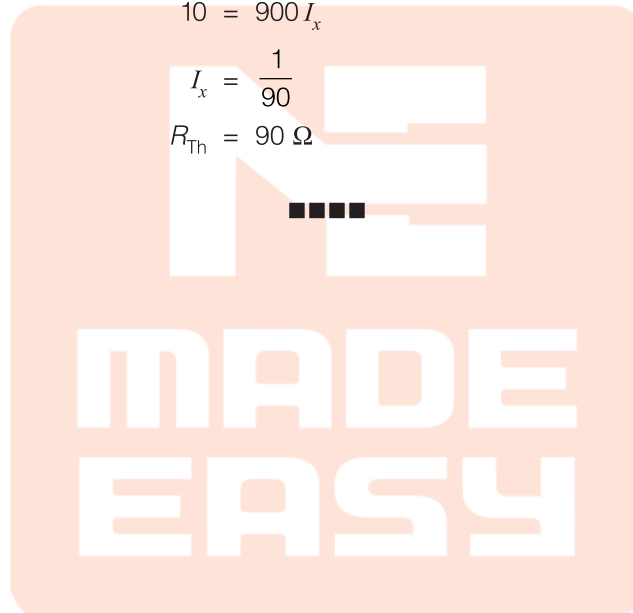

6

Two-Port Networks



Detailed Explanation of Try Yourself Questions

T1. (a)

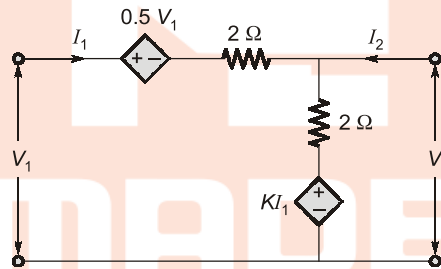

For $I_2 = 0$;

$$V_2 = (2 \times I_1 + KI_1)$$

$$V_2 = (2 + K) I_1$$

$$\frac{V_2}{I_1} = Z_{21} = (2 + K)$$

...(i)

For $I_1 = 0$;

$$Z_{12} = \frac{V_1}{I_2};$$

$$V_1 = 0.5 V_1 + 2I_2$$

⇒

$$0.5 V_1 = 2I_2$$

$$Z_{12} = \frac{V_1}{I_2} = 4$$

...(ii)

From equation (i) and (ii),

From reciprocal network,

∴

$$Z_{12} = Z_{21}$$

$$2 + K = 4$$

$$K = 2$$

T2. Sol.

To find Z_{22} ;

$$\therefore Z_{22} = \left. \frac{V_2}{I_2} \right|_{I_1=0}$$

For $I_1 = 0$;
 R_{Th} from port port-2.

$$R_{Th} = 1.732 \Omega$$

$$Z_{22} = 1.732 \Omega$$

T3. Sol.

$I_{SC} =$ for $V_2 = 0$;

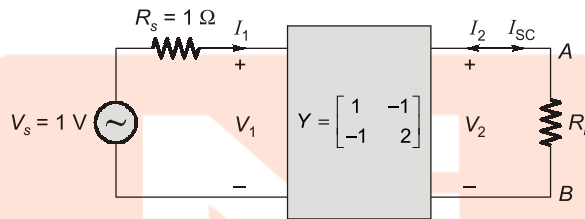

$$\begin{bmatrix} I_1 \\ I_2 \end{bmatrix} = \begin{bmatrix} 1 & -1 \\ -1 & 2 \end{bmatrix} \begin{bmatrix} V_1 \\ V_2 \end{bmatrix}$$

$$I_1 = V_1 - V_2$$

$$I_2 = V_1 - V_2$$

For $V_2 = 0$;

$$I_{SC} = -I_2 = -V_1$$

$$= -(V_s - I_1 R_s)$$

$$-V_1 = V_s + I_1 R_s$$

\therefore For $V_2 = 0$;
then,

$$I_1 = V_1$$

$$-V_1 = -V_s + V_1 \times R_s$$

$$V_s = V_1(1 + R_s)$$

$$V_1 = \frac{V_s}{(1 + R_s)} = \frac{1}{2}$$

Now,

$$I_{SC} = -V_1 = -0.5 \text{ A}$$

T4. Sol.

To find Z-parameters:

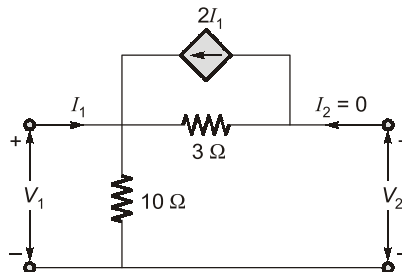

we need to get;

$$Z_{11} = \left. \frac{V_1}{I_1} \right|_{I_2=0}; \quad Z_{21} = \left. \frac{V_2}{I_1} \right|_{I_2=0}$$

then the circuit becomes,

$$V_1 = 10 I_1$$

$$Z_{11} = \frac{V_1}{I_1} = 10$$

and

$$V_2 = V_1 - 3 \times 2I_1$$

$$V_2 = 10I_1 - 6I_1; \quad Z_{21} = \frac{V_2}{I_1} = 4$$

For

$$Z_{12} = \left. \frac{V_2}{I_1} \right|_{I_2=0}$$

and

$$Z_{22} = \left. \frac{V_2}{I_2} \right|_{I_1=0}$$

then the circuit becomes,

$$V_1 = 10I_2;$$

$$Z_{12} = \frac{V_1}{I_2} = 10;$$

and

$$V_2 = 13I_2$$

$$Z_{22} = \frac{V_2}{I_2} = 13$$

then,

$$[Z] = \begin{bmatrix} 10 & 10 \\ 4 & 13 \end{bmatrix}$$

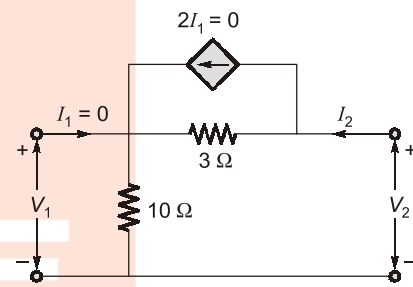

T5. Sol.

Given,

$$[h] = \begin{bmatrix} 16 \Omega & 3 \\ -2 & 0.015 \end{bmatrix}$$

∴

$$V_1 = 16 I_1 + 3 V_2 \quad \dots(i)$$

$$I_2 = -2I_1 + 0.01 V_2 \quad \dots(ii)$$

From the given circuit,

$$I_2 = -\frac{V_2}{25}$$

KVL in the loop: $-10 + 4I_1 + V_1 = 0$

$$I_1 = \frac{10 - V_1}{4}$$

Substituting I_1 and I_2 in the equation (i) and (ii),

$$V_1 = 16 \left(\frac{10 - V_1}{4} \right) + 3V_2$$

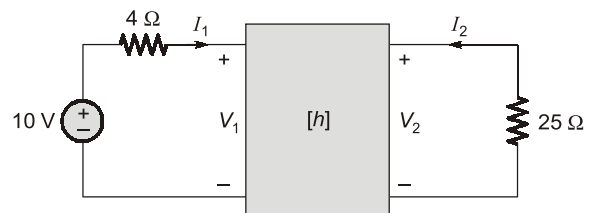

$$5 V_1 - 3 V_2 = 40$$

$$\left(-\frac{V_2}{25}\right) = -2\left(\frac{10-V_1}{4}\right) + 0.01 V_2$$

$$0.5 V_1 + 0.05 V_2 = 5$$

$$V_1 = 9.71 \text{ V}; \quad V_2 = 2.8571 \text{ V}$$

The ratio,

$$\frac{V_2}{V_1} = \frac{2.8571}{9.71} = 0.294$$

$$I_1 = \frac{10 - V_1}{4} = \frac{10 - 9.71}{4} = 0.072 \text{ A}$$

$$\frac{I_1}{V_1} = \frac{0.072}{9.71} = 0.0074 \text{ } \Omega$$

$$\frac{V_2}{I_1} = \frac{2.8571}{0.072} = 39.682 \text{ } \Omega$$

$$\frac{I_2}{I_1} = -0.11$$

T6. Sol.

$$\begin{bmatrix} A & B \\ C & D \end{bmatrix} = \begin{bmatrix} \frac{11}{34} & -10 \\ 1 & -4 \end{bmatrix}$$

T7. (c)

$$M = K\sqrt{L_1 \cdot L_2}$$

For first transformer,

$$M_1 = \frac{1}{2}\sqrt{3 \times 3} = \frac{3}{2} \text{ H}$$

For second transformer,

$$M_2 = \frac{2}{3}\sqrt{3 \times 3} = 2 \text{ H}$$

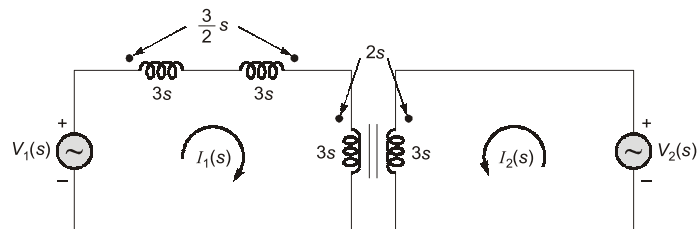

By KVL for Loop 1,

$$V_1(s) = 9s I_1(s) - 3s I_1(s) + 2s I_2(s)$$

$$V_1(s) = 6s I_1(s) + 2s I_2(s)$$

$$V_1 = Z_{11} I_1 + Z_{12} I_2$$

We find, $Z_{11} = 6s$
 $Z_{12} = 2s$
 By KVL for Loop 2, $V_2(s) = 2s I_1(s) + 3s I_2(s)$
 $V_2 = Z_{21} I_1 + Z_{22} I_2$
 We find, $Z_{21} = 2s$
 $Z_{22} = 3s$
 $\therefore [Z] = \begin{bmatrix} 6s & 2s \\ 2s & 3s \end{bmatrix}$

T8. (c)

From circuit,

$$V_1 = 100\angle 0^\circ$$

and

$$V_2 = -10 I_2$$

\therefore

$$V_1 = 40 I_1 + j20 I_2 \quad \text{(i)}$$

$$V_2 = j30 I_1 + 50 I_2 \quad \text{...(ii)}$$

From equation (ii),

$$-10 I_2 = j30 I_1 + 50 I_2$$

$$-60 I_2 = j30 I_1; \quad I_2 = -\frac{j}{2} \times I_1$$

From equation (i),

$$100 = 40 I_1 + j20 \times \left(-\frac{j}{2}\right) I_1$$

$$100 = 50 I_1$$

\Rightarrow

$$I_1 = 2\angle 0^\circ \text{ A}$$

then,

$$I_2 = -\frac{j}{2} \times 2 \text{ A} = 1\angle -90^\circ \text{ A}$$

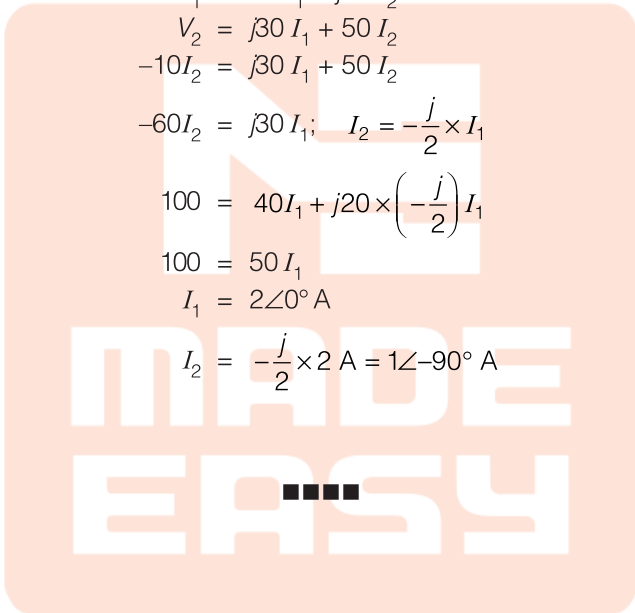

7

Resonance



Detailed Explanation of Try Yourself Questions

T1. Sol.

For reactive power from source to zero.
The network is behaving as purely resistive.

∴

$$Y_{eq} = Y_1 + Y_2$$

$$Y_{eq} = \frac{1}{R + X_L} + \frac{1}{R + X_C}$$

∴

$$X_L = j\omega L, \quad X_C = -j\frac{1}{\omega C} \quad \times$$

$$Y_{eq} = \frac{1}{R + j\omega L} + \frac{1}{R - \frac{j}{\omega C}}$$

$$= \frac{R - j\omega L}{R^2 + \omega^2 L^2} + \frac{R + \frac{j}{\omega C}}{R^2 + \frac{1}{\omega^2 C^2}}$$

$$= \frac{R}{R^2 + \omega^2 L^2} + \frac{R}{R^2 + \left(\frac{1}{\omega C}\right)^2} + j \left[\frac{\frac{1}{\omega C}}{R^2 + \frac{1}{\omega^2 C^2}} - \frac{\omega L}{R^2 + \omega^2 L^2} \right]$$

∴ $I_m(Y_{eq}) = 0$; for resistive network

$$\frac{\frac{1}{\omega C}}{R^2 + \frac{1}{\omega^2 C^2}} = \frac{\omega L}{R^2 + \omega^2 L^2}$$

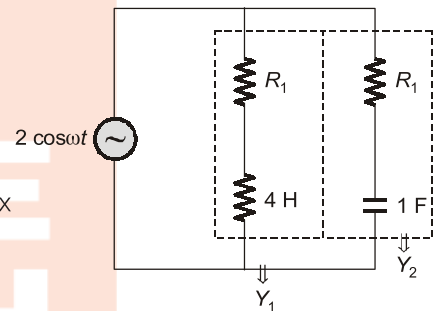

$$\frac{1}{\omega C} \times (R^2 + \omega^2 L^2) = \omega L \left(R^2 + \frac{1}{\omega^2 C^2} \right)$$

$$\frac{1}{\omega^2 LC} [R^2 + \omega^2 L^2] = R^2 + \frac{1}{\omega^2 C^2}$$

$$\frac{R^2}{\omega^2 LC} + \frac{L}{C} = R^2 + \frac{1}{\omega^2 C^2}$$

$$R^2 \left[1 - \frac{1}{\omega^2 LC} \right] = \frac{L}{C} - \frac{1}{\omega^2 C^2}$$

$$R^2 = \frac{\left(\frac{L}{C} - \frac{1}{\omega^2 C^2} \right)}{\left(1 - \frac{1}{\omega^2 LC} \right)}$$

$$R = \sqrt{\frac{\frac{L}{C} - \frac{1}{\omega^2 C^2}}{1 - \frac{1}{\omega^2 LC}}}$$

or,

$$L = 4 \text{ H}, C = 1 \text{ F}$$

$$R = \sqrt{\frac{4 - \frac{1}{\omega^2}}{1 - \frac{1}{4\omega^2}}} = 2 \Omega$$

T2. (a)

Voltage across 'R' is maximum.

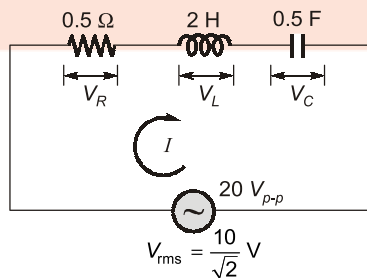

When V_C and V_L are in phase opposition i.e. at resonance.

∴ At resonance:

Total impedance,

$$Z = R = 0.5 \Omega$$

Current,

$$I = \frac{10/\sqrt{2}}{0.5} = \frac{20}{\sqrt{2}} = 10\sqrt{2} = 14.142 \text{ A}$$

Voltage across capacitor,

$$V_C = \frac{I}{\omega_0 C}$$

\therefore

$$\omega_0 = \frac{1}{\sqrt{LC}}$$

$$V_C = \frac{I}{\frac{1}{\sqrt{LC}} \times C} = I \sqrt{\frac{L}{C}}$$

$$= 10\sqrt{2} \sqrt{\frac{2}{0.5}} = 10\sqrt{2} \times 2 = 20\sqrt{2}$$

$$= \frac{40}{\sqrt{2}} \text{ V}$$

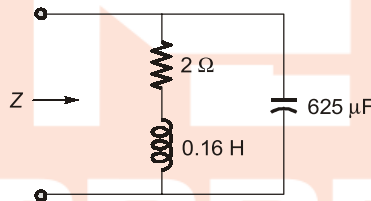
T3. (c)**T4. (d)** \therefore At resonance,

$$\omega_0 = \sqrt{\frac{1}{LC} - \frac{R^2}{L^2}}$$

$$= \sqrt{\frac{10^6}{0.16 \times 625} - \frac{4}{0.16 \times 0.16}} = \sqrt{10^4 - 156.25}$$

$$= 99.216 \text{ rad/sec.}$$

$$Z \text{ at } \omega = \omega_0 = \frac{\omega_0^2 L^2}{R} + R = 2 + \frac{(99.216)^2 \times (0.16)^2}{2}$$

$$= 2 + 126 = 128 \Omega$$

T5. Sol.

(i) At resonance;

$$Y_{eq} = G_{eq} = \frac{R}{R^2 + \frac{1}{(\omega C)^2}} + \frac{R}{R^2 + (\omega L)^2}$$

Average power consumed,

$$P = V_{rms}^2 \times G_{eq} = (20/\sqrt{2})^2 \times G_{eq}$$

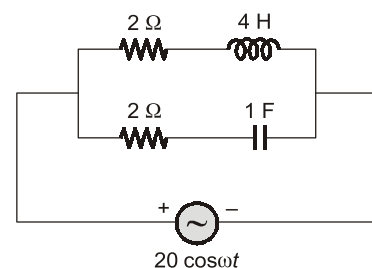

$$\therefore \omega_0 \text{ (resonant frequency)} = \frac{1}{\sqrt{LC}} = \frac{1}{\sqrt{4 \times 1}} = 0.5 \text{ rad/sec.}$$

$$G_{eq} = \frac{2}{4 + \frac{1}{(0.5 \times 1)^2}} + \frac{2}{4 + (0.5 \times 4)^2}$$

$$= \frac{2}{4+4} + \frac{2}{4+4} = 0.5 \text{ } \Omega$$

$$P = \frac{20^2}{2} \times 0.5 = 100 \text{ W}$$

(ii)

$$R_1 = R_2 = R = 2 \text{ } \Omega$$

$$L = 1 \text{ H; } C = 1 \text{ F}$$

$$\omega_0 = \frac{1}{\sqrt{1 \times 1}} = 1 \text{ rad/sec.}$$

$$G_{eq} = \frac{2}{(2)^2 + (1 \times 1)^2} + \frac{2}{(2)^2 + \left(\frac{1}{1 \times 1}\right)^2}$$

$$= \frac{2+2}{4+1} = \frac{4}{5} \text{ } \Omega$$

$$P = \frac{(20)^2 \times 4}{2 \times 5} = 160 \text{ W}$$

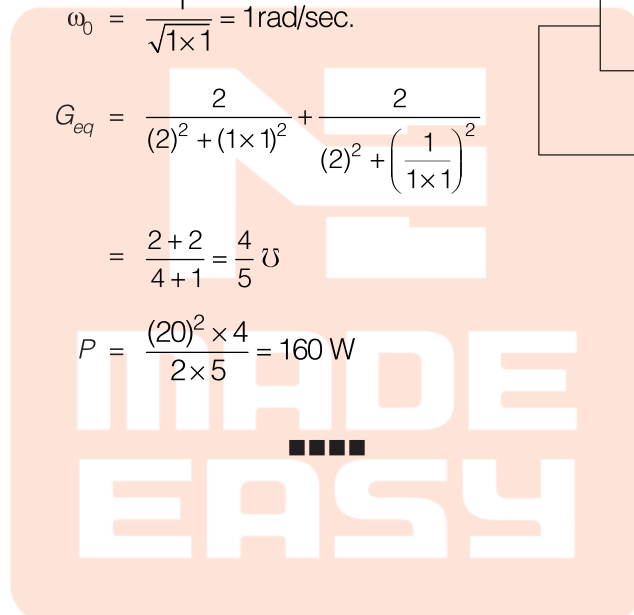
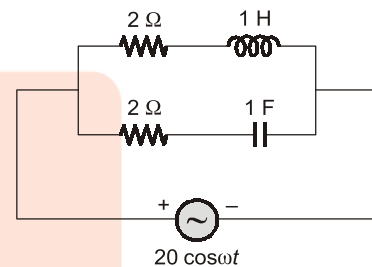

8

Filters and Magnetic Coupled Circuits



Detailed Explanation of Try Yourself Questions

T1. (c)

T2. (c)

In phaser domain,

$$L \Rightarrow j\omega L$$

$$C \Rightarrow \frac{1}{j\omega C} = \frac{1}{j(10^5)(62.5 \times 10^{-12})} = -j160 \text{ k}\Omega$$

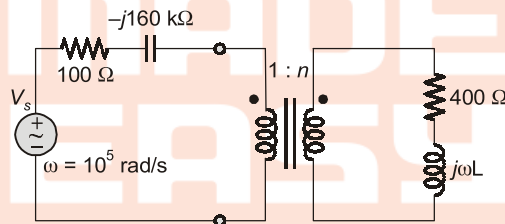

Load impedance,

$$Z_L = 400 + j\omega L$$

Reflecting the secondary impedance to the primary side

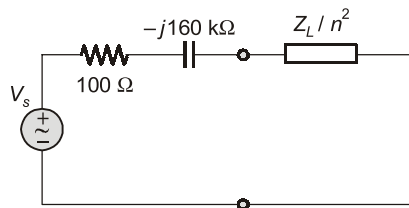

For maximum power transfer

$$Z_L/n^2 = Z_s^*$$

$$\frac{Z_L}{n^2} = (100 - j160 \times 10^3) \quad Z_s = (100 - j160 \times 10^3) \Omega$$

$$\frac{400 + j\omega L}{n^2} = 100 + j160 \times 10^3$$

Comparing real parts on both sides of the equation,

$$\frac{400}{n^2} = 100 \Rightarrow n = 2$$

Comparing imaginary parts,

$$\frac{\omega L}{n^2} = 160 \times 10^3$$

$$\Rightarrow L = \frac{160 \times 10^3}{10^5} \times 4 = 6.4 \text{ H}$$

