

ESE

GATE

State Engg. Exams

MADE EASY
WORKBOOK 2027



**Detailed Explanations of
Try Yourself *Questions***

Electrical Engineering
Control Systems



1

Mathematical Models and Block Diagram



Detailed Explanation of Try Yourself Questions

T1. (b)

Drawing SFG of the above

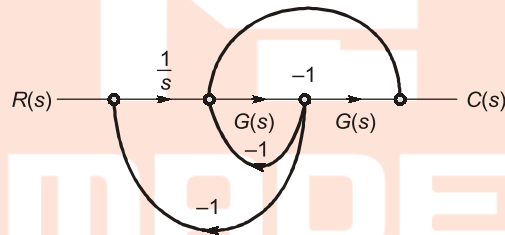

Here, $P_1 = \frac{G^2(s)}{s}$; $L_2 = -G(s)$; $L_1 = -G^2(s)$; $L_3 = -\frac{G(s)}{s}$

$$\frac{C(s)}{R(s)} = \frac{\frac{G^2(s)}{s}}{1 - \left(-G^2(s) - \frac{G(s)}{s} - G(s) \right)}$$

$$= \frac{G^2(s)}{s + sG^2(s) + G(s) + sG(s)}$$

Put $G(s) = s$,

$$\frac{C(s)}{R(s)} = \frac{s^2}{s + s^3 + s + s^2} = \frac{s^2}{s^3 + s^2 + 2s} = \frac{s}{s^2 + s + 2}$$

T2. Sol.

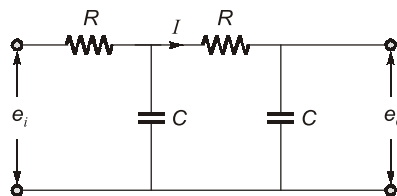

$$E_o(s) = \frac{1}{sC} I(s) \quad \dots(i)$$

$$I(s) = \frac{E_i(s)}{\left[R + \frac{\left(R + \frac{1}{sC} \right) \times \frac{1}{sC}}{\left(R + \frac{1}{sC} + \frac{1}{sC} \right)} \right]} \times \frac{\frac{1}{sC}}{\left(R + \frac{1}{sC} + \frac{1}{sC} \right)}$$

(Using current division rule)

$$= \frac{E_i(s)}{R + \frac{1}{\frac{sC}{sCR+2} + R}} \times \frac{1}{sCR+2} = \frac{E_i(s)}{\left(R + \frac{1}{sC} \right) + R(sCR+2)}$$

$$E_o(s) = \frac{\frac{1}{sC} \times E_i(s)}{\frac{(1+RSC) + SCR(SCR+2)}{SC}}$$

$$\frac{E_o(s)}{E_i(s)} = \frac{1}{S^2C^2R^2 + 3SCR + 1} = \frac{1}{S^2T^2 + 3ST + 1}$$

T3. (b)

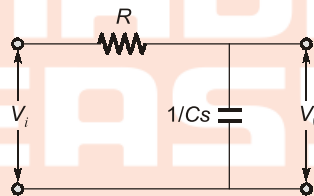

$$\frac{V_o}{V_i} = \frac{1/Cs}{R + \frac{1}{Cs}} = \frac{1}{RCs + 1}$$

■■■■

2

Time Response Analysis



Detailed Explanation of Try Yourself Questions

T1. Sol.

$$G(s) = \frac{K}{s(s+p)}$$

Now, the closed loop system

$$T(s) = \frac{K}{s^2 + sp + K}$$

∴ Comparing it with standard equation

$$K = \omega_n^2$$

$$2\xi\omega_n = p$$

$$t_s = \frac{4}{\xi\omega_n}$$

⇒

$$\xi\omega_n = 1$$

∴

$$p = 2$$

now,

$$e^{\frac{-\pi\xi}{\sqrt{1-\xi^2}}} = 0.1$$

$$\xi = 0.537$$

∴

$$\omega_n = \frac{p}{2\xi} = 1.69$$

∴

$$K = \omega_n^2 = 2.85$$

T2. Sol.

Taking Laplace transform we get

$$X(s) = \frac{1}{(s^2 + 6s + 5)} \cdot 12 \left[\frac{1}{s} - \frac{1}{(s+2)} \right]$$

$$X(s) = \frac{12}{s(s+5)(s+1)} \cdot 12 \left[\frac{1}{s} - \frac{1}{(s+2)} \right]$$

Now, using final value theorem

$$\lim_{t \rightarrow \infty} x(t) = \lim_{s \rightarrow 0} sX(s)$$

$$\begin{aligned} \therefore X(s) &= \lim_{s \rightarrow 0} \left[\frac{12}{(s+5)(s+1)} - \frac{12s}{(s+5)(s+1)(s+3)} \right] \\ &= \frac{12}{5} = 2.4 \end{aligned}$$

T3. Sol.

To find the impulse response let us difference the response.

$$c'(t) = 12 e^{-10t} - 12e^{-60t}$$

taking inverse laplace transform we get

$$C'(s) = \frac{600}{(s+10)(s+60)}$$

$$C'(s) = \frac{600}{s^2 + 70s + 600}$$

$\therefore c'(s)$ is the impulse response thus comparing it with the standard equation.

$$2\xi\omega_n = 70$$

$$\omega_n = \sqrt{600}$$

$$\xi = 1.428 \approx 1.43$$

\therefore

T4. Sol.

Since real part of the given second order equation is at -0.602 thus they can be considered as dominant poles.

Thus

$$t_p = \frac{\pi}{\omega_d}$$

$$\omega_d = \omega_n \sqrt{1 - \xi^2}$$

$$\omega_n = \sqrt{2.829} = 1.6819$$

and

$$2\xi\omega_n = 1.204$$

$$\xi = \frac{1.204}{2 \times 1.6819} = 0.3579$$

\therefore

$$\omega_d = 1.6819 \sqrt{1 - \xi^2}$$

$$\omega_d = 1.577$$

\therefore

$$t_p = 1.999 \approx 2$$





Detailed Explanation of Try Yourself Questions

T1. (d)

T2. (d)

The correct sequence of steps needed to improve system stability is to use negative feedback, reduce gain and insert deviation action.

T3. Sol.

$$1 + G(s) = 0$$

$$\Rightarrow s\tau_1 [1 + s(\tau_1 + \tau_2) + s^2 \tau_1 \tau_2] + K = 0$$

$$s^3 \tau_1^2 \tau_2 + s^2 \tau_1(\tau_1 + \tau_2) + s\tau_1 + K = 0$$

Using R-H criteria

s^3	$\tau_1^2 \tau_2$	τ_1
s^2	$\tau_1(\tau_1 + \tau_2)$	K
s^1	$\frac{[\tau_1^2(\tau_1 + \tau_2) - K\tau_1^2 \tau_2]}{\tau_1(\tau_1 + \tau_2)}$	
s^0	K	

$$\Rightarrow K > 0; \tau_1 > 0; \tau_2 > 0$$

Also,

$$\frac{\tau_1(\tau_1 + \tau_2) - K\tau_2}{(\tau_1 + \tau_2)} > 0$$

$$K\tau_2\tau_1 < \tau_1(\tau_1 + \tau_2)$$

$$\Rightarrow K < \left(1 + \frac{\tau_1}{\tau_2}\right)$$

$$0 < K < \left(1 + \frac{\tau_1}{\tau_2}\right); [\tau_1 > 0 \text{ and } \tau_2 > 0 \text{ and this is the only possible case.}]$$



4

Root Locus Technique



Detailed Explanation of Try Yourself Questions

T1. Sol.

Characteristic equation is given as

$$1 + G(s)H(s) = 0$$

On comparing this characteristic equation with the equation given in problem, we have

$$G(s)H(s) = \frac{K}{s(s+1)(s+2)}$$

$P =$ Number of open loop poles $= 3 =$ number of branches on root locus

$Z = 0 =$ Number of branches terminating at zeros.

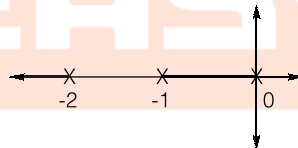

Angle of Asymptotes: The $P - Z$ branches terminating at infinity will go along certain straight lines.

$$\text{Number of asymptotes} = P - Z$$

$$= 3 - 0 = 3$$

$$\theta = \frac{180^\circ(2q+1)}{P-Z} \quad q = 0, 1, 2 \dots$$

$$\theta_1 = \frac{180 \times (2 \times 0 + 1)}{3} = 60^\circ$$

$$\theta_2 = \frac{180^\circ(2 \times 1 + 1)}{3} = 180^\circ$$

$$\theta_3 = \frac{180^\circ(2 \times 2 + 1)}{3} = 300^\circ$$

Centroid: It is the intersection point of the asymptotes on the real axis. It may or may not be a part of root locus.

$$\begin{aligned}\text{Centroid} &= \frac{\sum \text{Real part of open loop poles} - \sum \text{Real part of open loop zeros}}{P - Z} \\ &= \frac{0 - 1 - 2}{3} = -1\end{aligned}$$

Centroid $\rightarrow (-1, 0)$

Break-away or break-in points: These are those points on whose multiple roots of the characteristic equation occur.

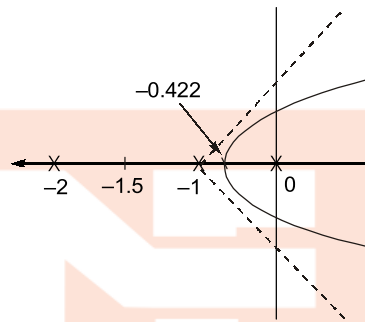

$$s(s^2 + 3s + 2) + K = 0$$

$$K = -(s^3 + 3s^2 + 2s)$$

$$\frac{dK}{ds} = -(3s^2 + 6s + 2) = 0$$

$$s = -0.422, -1.577$$

Now verify the valid break-away point

$$K = 0.234 \text{ (valid) at } s = -0.422$$

$$K = \text{negative (not valid) at } s = -1.577$$

T2. Sol.

$$OLTF = \frac{K}{s(s^2 + 4s + 8)}$$

Poles are at

$$s_1 = 0$$

and

$$s_{2,3} = \frac{-4 \pm \sqrt{16 - 32}}{2} = -2 \pm j2$$

There are 3 poles and no zero with root loci, all terminating at infinity.

$$\phi = \frac{(2q + 1)180^\circ}{P - Z} = 60^\circ, 180^\circ, 300^\circ \text{ for } q = 0, 1, 2 \text{ (angle of}$$

asymptotes)

$$\text{Centroid} = \frac{0 - 2 + j2 - 2 - j2}{3} = \frac{-4}{3} = -1.33$$

$$1 + \frac{K}{s(s^2 + 4s + 8)} = 0$$

$$\Rightarrow K = -s(s^2 + 4s + 8) = -(s^3 + 4s^2 + 8s)$$

for break away points, $\frac{dK}{ds} = 0$

$$\Rightarrow \frac{dK}{ds} = -(3s^2 + 8s + 8)$$

$$s_{1,2} = -\frac{8 \pm \sqrt{64 - 4 \times 8 \times 3}}{2 \times 3}$$

$$= -\frac{8 \pm \sqrt{64 - 96}}{6} = -1.33 \pm j0.943$$

As $\frac{dK}{ds}$ is imaginary, there is no breakaway point from the real axis.

Imaginary axis crossing:

$$\begin{aligned} \text{Characteristic equation} &= s(s^2 + 4s + 8) + K \\ &= s^3 + 4s^2 + 8s + K = 0 \end{aligned}$$

s^3	1	8
s^2	4	K
s^1	$\frac{32-K}{4}$	
s^0	K	

From Routh-Hurwitz Criteria:

For $K = 32$, the system is marginally stable and beyond $K = 32$ the system becomes unstable. Hence,

$$4s^2 + K = 4s^2 + 32$$

$$s = j2\sqrt{2} = j\omega$$

$$\omega = 2\sqrt{2} = 2.83$$

The root locus cuts the imaginary axis at $\pm j2.83$.

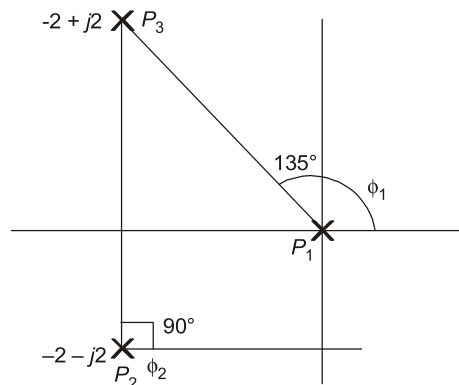

$$\phi_1 = 180^\circ - \tan^{-1}\left(\frac{2}{2}\right) = 135^\circ$$

$$\begin{aligned}\phi_2 &= 90^\circ \\ \Sigma\phi_p &= \phi_1 + \phi_2 = 135^\circ + 90^\circ = 225^\circ \\ \phi &= \Sigma\phi_z - \Sigma\phi_p = 0 - 225^\circ = -225^\circ\end{aligned}$$

Angle of departure,

$$\phi_D = 180 + \phi = 180 - 225^\circ = -45^\circ$$

Root locus of the given system:

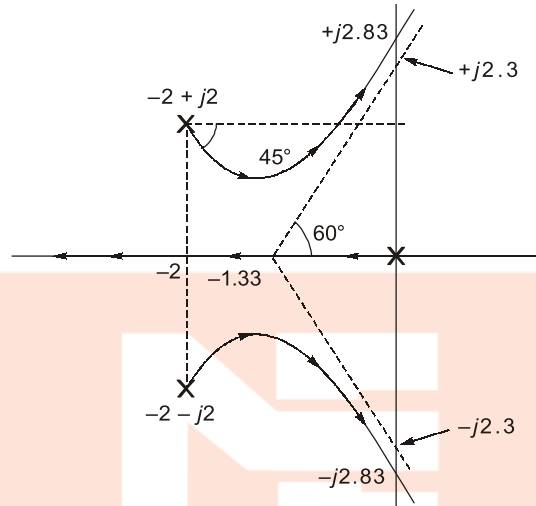

T3. Sol.

$$G(s)H(s) = \frac{K}{s(s+1)(s+4)}$$

Step-1 Number of open loop poles ;

$$P = 3$$

Number of open loop zeros ; $Z = 0$

Number of branches terminating at infinity

$$= P - Z = 3$$

Step-2 Angle of asymptotes

$$\theta = \frac{(2q+1)180^\circ}{P-Z} \quad \text{where } q = 0, 1, 2$$

$$\theta_1 = \frac{180^\circ}{3} = 60^\circ$$

$$\theta_2 = \frac{3 \times 180^\circ}{3} = 180^\circ$$

$$\theta_3 = \frac{5 \times 180^\circ}{3} = 300^\circ$$

Step-3

$$\text{Centroid} = \frac{\Sigma \text{ real part of open loop poles} - \Sigma \text{ real part of open loop zeros}}{P - Z}$$

$$= \frac{(-1-4) - (0)}{3-0} = -\frac{5}{3}$$

Step-4 Break away point

$$K + s(s^2 + 5s + 4) = 0$$

$$K = -s^3 - 5s^2 - 4s$$

$$\frac{dK}{ds} = -3s^2 - 10s - 4 = 0$$

$$3s^2 + 10s + 4 = 0$$

$$\Rightarrow s_1, s_2 = -0.4648, -2.8685$$

Valid break-away point will be -0.4648

(i) Routh array table

$$\begin{array}{c|cc} s^3 & 1 & 4 \\ s^2 & 5 & K \\ s^1 & \frac{20-K}{5} & 0 \\ s^0 & 1 & \end{array}$$

For system to be stable

$$20 - K > 0 \Rightarrow K < 20$$

For system to be marginally stable.

$$K = 20$$

$$A(s) = 5s^2 + 20 = 0$$

$$\Rightarrow s = \pm 2j$$

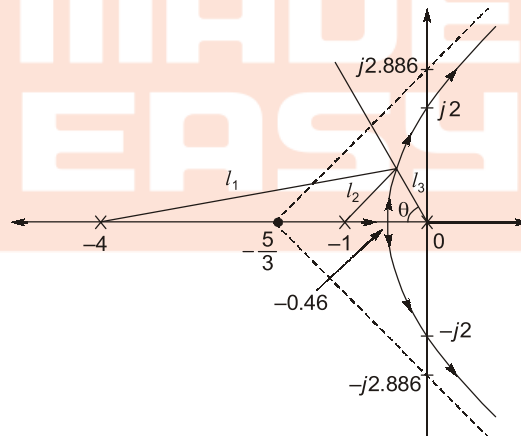

(ii) To find K ,

$$\theta = \cos^{-1} \xi = \cos^{-1}(0.34) = 70.123^\circ$$

$$K = l_1 l_2 l_3$$

$$\text{Gain margin (GM)} = \frac{K(\text{Marginal stability})}{K(\text{desired})}$$

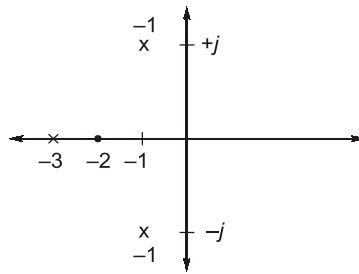
T4. Sol.

$$\begin{aligned}\phi_a &= 180 - (\phi_p - \phi_z) \\ &= 180 - \left(180 + \tan^{-1}\left(\frac{1}{2}\right) + 90 - 225^\circ \right) \\ &= 108.4^\circ\end{aligned}$$

T5. Sol.

Given that

$$G(s) = \frac{K}{(s+2)(s-1)}$$

Using root locus method, the break point can be

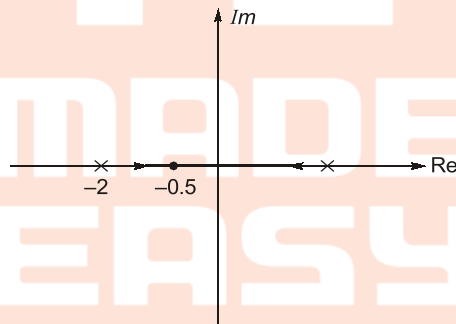

obtain as

⇒

$$1 + G(s) = 0$$

$$1 + \frac{K}{(s+2)(s-1)} = 0$$

or

$$K = -(s+2)(s-1)$$

$$\frac{dK}{ds} = -2s - 1 = 0$$

or

$$s = -0.5$$

To have, both the poles at the same directions

$$|G(s)|_{s=-0.5} = 1$$

$$K = 2.25$$



5

Frequency Response Analysis



Detailed Explanation of Try Yourself Questions

T1. Sol.

Given,

$$G(s) = \frac{K(1+0.5s)(1+as)}{s\left(1+\frac{s}{8}\right)(1+bs)\left(1+\frac{s}{36}\right)}$$

$(1 + as)$ is addition of zero to the transfer function whose contribution in slope = +20 dB/decade or -6 dB/octave.

$(1 + bs)$ is addition of pole to the transfer function whose contribution in slope = -20 dB/decade or -6 dB/octave

Observing the change in the slope at different corner frequencies, we conclude that

$$a = \frac{1}{4} \text{ rad/s and } b = \frac{1}{24} \text{ rad/s}$$

From

$$\omega = 0.01 \text{ rad/s to } \omega = 8 \text{ rad/s,}$$

slope = -20 dB/decade

Let the vertical length in dB be y

$$\therefore -20 = \left(\frac{0 - y}{\log 8 - \log 0.01} \right)$$

$$\text{or, } -20 = \frac{y}{\log 8 + 2}$$

$$\text{or, } y = 58 \text{ dB}$$

$$\text{Applying } y = mx + C \text{ at } \omega = 0.01 \text{ rad/s,}$$

$$\text{we have: } 58 = -20 \log 0.01 + C$$

$$\text{or, } C = 58 - 40 = 18$$

$$\text{Now, } C = 20 \log K$$

$$\text{or, } \log K = \frac{18}{20} = 0.9$$

$$\therefore K = \log^{-1}(0.9) = (10)^{0.9} = 7.94$$

$$\therefore \frac{a}{bK} = \frac{\left(\frac{1}{4}\right)}{\left(\frac{1}{24}\right) \times 7.94}$$

$$= \frac{24}{4 \times 7.94} = 0.755$$

$$\therefore \frac{a}{bK} = 0.755$$

T2. Sol.

$$\text{OLTF} = G(s) = \frac{1}{(s+2)^2}$$

For unity feedback system,

$$H(s) = 1$$

$$\therefore \text{CLTF} = \frac{G(s)}{1+G(s)H(s)} = \frac{\frac{1}{(s+2)^2}}{1+\frac{1}{(s+2)^2}}$$

$$= \frac{1}{s^2 + 4s + 5}$$

\therefore Close loop poles will be the roots of $s^2 + 4s + 5 = 0$

i.e. $s = -2 + j$ and $-2 - j$

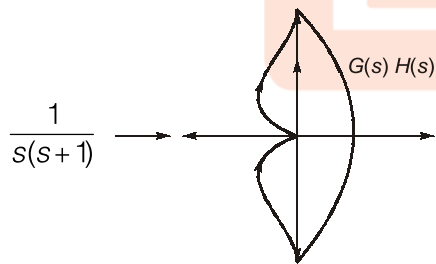
T3. (b)

After adding pole at origin

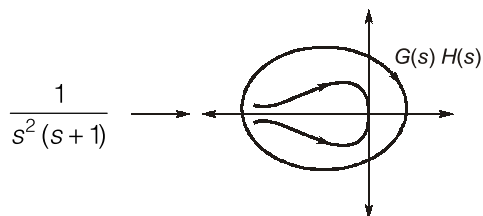

So, nyquist plot of a system will rotate by 90° in clockwise direction.

T4. Sol.

For gain margin we have to find

$$G(s)H(s) = \frac{0.75}{s(1+s)(1+0.5s)}$$

Phase over frequency

$$-180^\circ = -90^\circ - \tan^{-1}(\omega) - \tan^{-1}(0.5\omega)$$

$$-90^\circ = \tan^{-1}(\omega) + \tan^{-1}(0.5\omega)$$

$$\frac{1.5\omega}{1-0.5\omega^2} = \tan(90^\circ)$$

$$0.5\omega^2 = 1$$

$$\omega = \sqrt{2}$$

$$\therefore |G(j\omega)H(j\omega)| = \frac{0.75}{\omega\sqrt{1+\omega^2}\sqrt{1+0.25\omega^2}} = \frac{0.75}{\sqrt{2}\sqrt{1+2}\sqrt{1+0.5}} = \frac{1}{4}$$

$$\therefore \text{Gain margin} = 20 \log \frac{1}{|G(j\omega)H(j\omega)|} = 20 \log 4 = 12 \text{ dB}$$

T5. Sol.

$$-90^\circ - \tan^{-1}(2\omega) - \tan^{-1}(3\omega) = -180^\circ$$

$$\tan^{-1}(2\omega) + \tan^{-1}(3\omega) = 90^\circ$$

$$\frac{5\omega}{1-6\omega^2} = \tan(90^\circ)$$

$$\therefore 1-6\omega^2 = 0$$

$$\omega = \frac{1}{\sqrt{6}} = 0.41$$

T6. Sol.

The Bode plot is of type zero system
thus steady state error

$$e_{ss} = \frac{1}{1+K_p}$$

Where

K_p = propotional error constant

K_p = 40 db

or

K_p = 100

$$\therefore e_{ss} = \frac{1}{1+100} = \frac{1}{101} = 0.009$$



6

Controllers and Compensators



Detailed Explanation of Try Yourself Questions

T1. Sol.

The given compensator represents phase lead compensator having maximum phase

$$\phi = \sin^{-1}\left(\frac{1-\alpha}{1+\alpha}\right)$$

Here,

$$\alpha = \frac{R_2}{R_1 + R_2} = \frac{(1/2)\Omega}{1 + (1/2)\Omega} = 0.333$$

\therefore

$$\phi = \sin^{-1}\left(\frac{1-0.333}{1+0.333}\right) = \sin^{-1}\left(\frac{0.667}{1.33}\right) = \sin^{-1}(0.5) = 30^\circ$$

T2. (a)

The effect of addition of a zero to a transfer function is providing a phase lead.

T3. Sol.

$$G(s) = \frac{\left(1 + \frac{s}{4}\right)}{\left(1 + \frac{s}{25}\right)}$$

Comparing it with the standard transfer function of phase lead compensator

$$G(s) = \frac{\alpha(1+Ts)}{(1+\alpha Ts)}$$

$$T = \frac{1}{4}, \quad \alpha T = \frac{1}{25}$$

Now, frequency ω_m occurs at

$$= \sqrt{\frac{1}{\alpha T} \cdot \frac{1}{T}} = \sqrt{25 \times 4} = 10 \text{ rad/sec.}$$



7

State Space Analysis



Detailed Explanation of Try Yourself Questions

T1. (b)

T2. Sol.

Given

$$\dot{x}(t) = Ax(t), \quad x(0) = x_0$$

Taking the Laplace transform

$$sX(s) - x(0) = AX(s)$$

$$[sI - A] X(s) = x(0)$$

$$X(s) = [sI - A]^{-1} x(0)$$

$$x(t) = \mathcal{L}^{-1}[sI - A]^{-1} x(0) \quad \dots(i)$$

Conditions given are

For

$$x_0 = \begin{bmatrix} 1 \\ -1 \end{bmatrix}, \quad x(t) = \begin{bmatrix} e^{-t} \\ -e^{-t} \end{bmatrix}$$

For

$$x_0 = \begin{bmatrix} 0 \\ 1 \end{bmatrix}, \quad x(t) = \begin{bmatrix} e^{-t} - e^{-2t} \\ -e^{-t} + 2e^{-2t} \end{bmatrix}$$

Using the linearity property in equation (i)

$$K_1 x_1(t) = \mathcal{L}^{-1}[sI - A]^{-1} x_1(0) K_1$$

$$K_2 x_2(t) = \mathcal{L}^{-1}[sI - A]^{-1} x_2(0) K_2$$

Using the linearity property as

$$K_1 x_1(t) + K_2 x_2(t) = \mathcal{L}^{-1}[sI - A]^{-1}$$

$$[K_1 x_1(0) + K_2 x_2(0)]$$

...(ii)

Also

$$X_3(s) = [sI - A]^{-1} x_3(0)$$

So,

$$K_1 \begin{bmatrix} 1 \\ -1 \end{bmatrix} + K_2 \begin{bmatrix} 0 \\ 1 \end{bmatrix} = \begin{bmatrix} 3 \\ 5 \end{bmatrix}$$

$$\begin{bmatrix} K_1 + 0K_2 \\ -K_1 + K_2 \end{bmatrix} = \begin{bmatrix} 3 \\ 5 \end{bmatrix}$$

$$\Rightarrow \begin{aligned} K_1 &= 3 \\ K_2 &= 8 \end{aligned}$$

So, from equation (ii), we get $x(t)$

$$\begin{aligned} x(t) &= K_1 x_1(t) + K_2 x_2(t) \\ &= 3 \begin{bmatrix} e^{-t} \\ -e^{-t} \end{bmatrix} + 8 \begin{bmatrix} e^{-t} - e^{-2t} \\ -e^{-t} + 2e^{-2t} \end{bmatrix} \\ &= \begin{bmatrix} 11e^{-t} - 8e^{-2t} \\ -11e^{-t} + 16e^{-2t} \end{bmatrix} \end{aligned}$$

T3. Sol.

Given

$$\begin{bmatrix} \dot{x}_1 \\ \dot{x}_2 \end{bmatrix} = \begin{bmatrix} 0 & 1 \\ 0 & 0 \end{bmatrix} \begin{bmatrix} x_1 \\ x_2 \end{bmatrix}$$

$$A = \begin{bmatrix} 0 & 1 \\ 0 & 0 \end{bmatrix}$$

$$[sI - A] = \begin{bmatrix} s & 0 \\ 0 & s \end{bmatrix} - \begin{bmatrix} 0 & 1 \\ 0 & 0 \end{bmatrix} = \begin{bmatrix} s & -1 \\ 0 & s \end{bmatrix}$$

$$[sI - A] = s^2$$

$$\phi(t) = \mathcal{L}^{-1}[sI - A]^{-1}$$

$$= \frac{1}{s^2} \begin{bmatrix} s & 1 \\ 0 & s \end{bmatrix}$$

$$= \mathcal{L}^{-1} \begin{bmatrix} \frac{1}{s} & \frac{1}{s^2} \\ 0 & \frac{1}{s} \end{bmatrix} = \begin{bmatrix} 1 & t \\ 0 & 1 \end{bmatrix}$$

T4. (b)

$$\begin{bmatrix} \dot{x}_1 \\ \dot{x}_2 \\ \dot{x}_3 \end{bmatrix} = \begin{bmatrix} -1 & 1 & 0 \\ 0 & -1 & 0 \\ 0 & 0 & -2 \end{bmatrix} \begin{bmatrix} x_1 \\ x_2 \\ x_3 \end{bmatrix} + \begin{bmatrix} 0 \\ 4 \\ 0 \end{bmatrix} u$$

$$y = \begin{bmatrix} 1 & 1 & 1 \end{bmatrix} \begin{bmatrix} x_1 \\ x_2 \\ x_3 \end{bmatrix}$$

$$A = \begin{bmatrix} -1 & 1 & 0 \\ 0 & -1 & 0 \\ 0 & 0 & -2 \end{bmatrix}, B = \begin{bmatrix} 0 \\ 4 \\ 0 \end{bmatrix}, C = [1 \ 1 \ 1]$$

Check for controllability:

$$Q_c = [B : AB : A^2B]$$

$$= \begin{bmatrix} 0 & 4 & -8 \\ 4 & -4 & 4 \\ 0 & 0 & 0 \end{bmatrix}$$

For controllable

$$|Q_c| \neq 0$$

Here,

$$|Q_c| = 4(0) = 0 \therefore \text{Uncontrollable.}$$

Check for observability:

$$Q_o = [C^T : A^T C^T : A^{2T} C^T]$$

$$= \begin{bmatrix} 1 & -1 & 1 \\ 1 & 0 & -1 \\ 1 & -2 & 4 \end{bmatrix}$$

For observable

$$|Q_o| \neq 0$$

Here

$$|Q_o| = 1 \therefore \text{Observable.}$$

T5. Sol.

$$\text{Characteristic equation} = |(sI - A)^{-1}|$$

$$= \begin{bmatrix} 2 & -1 \\ 3 & s+5 \end{bmatrix}^{-1}$$

$$= s(s+5) + 3$$

$$= s^2 + 5s + 3$$

