

ESE GATE PSUs

State Engg. Exams

MADE EASY
WORKBOOK 2027



**Detailed Explanations of
Try Yourself *Questions***

ELECTRICAL ENGINEERING

Analog Electronics



2

Bipolar Junction Transistor



Detailed Explanation of Try Yourself Questions

T1. (c)

In active region

$$-5 - 0.7 - 4.3 I_E = -10$$

$$I_E = \frac{10 - 5.7}{4.3} = \frac{4.3}{4.3} = 1 \text{ mA}$$

$$I_C = I_E = I' + 0.5 \text{ mA} = 1 \text{ mA}$$

$$\Rightarrow I' = 0.5 \text{ mA}$$

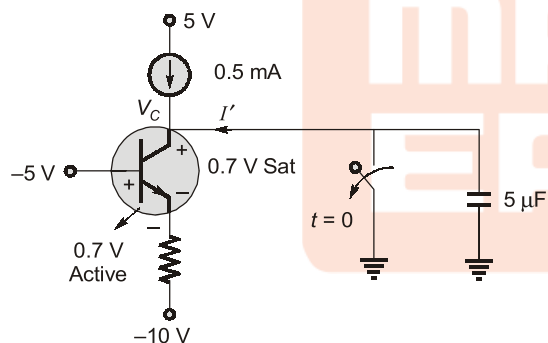

In saturation region \Rightarrow

$$V_C - 0.7 - 4.3 \times 1 = -10$$

$$V_C = -5 \text{ V}$$

$$q = CV_C = -5 \times 10^{-6} \times 5 \text{ V} = -25 \times 10^{-6}$$

and $q = it$

$$I'(0 - t) = -25 \times 10^{-6}$$

$$t = \frac{25 \times 10^{-6}}{0.5 \times 10^{-3}} = 50 \text{ m sec}$$

T2. Sol.

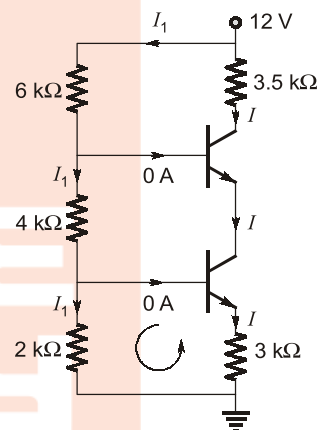

$$I_1 = \frac{12}{6 + 4 + 2} \text{ mA}$$

$$I_1 = 1 \text{ mA}$$

Applying KVL in loop L

$$I_1 \times 2 \text{ k}\Omega - I \times 3 \text{ k}\Omega = V_{BE}$$

$$2 - I \times 3 \text{ k} = 0.5$$

$$-I \times 3 \text{ k} = -1.5$$

$$I = \frac{-1.5}{-3} \times 10^{-3} = 0.5 \text{ mA}$$

T3. (a)

$$I_{ref} = \frac{9 - 0.7}{30 \times 10^3} = 0.277 \text{ mA}$$

at node 'a' $I_{ref} = I_C + 3I_B$
(I_{B3} is assumed negligible)

$$= I_C \left(1 + \frac{3}{\beta} \right)$$

$$I_C = I_{ref} \left(\frac{\beta}{3 + \beta} \right)$$

$$= 0.277 \times 10^{-3} \left(\frac{125}{128} \right)$$

$$I_{C1} = 0.27 \text{ mA}$$

T4. (c)

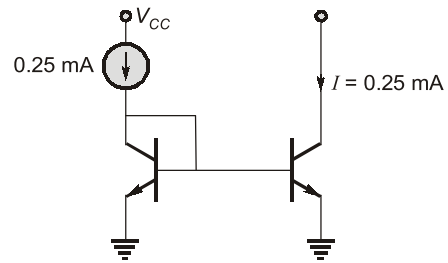

Using current mirror concept,
For large ' β ',

$$I = I_{ref}$$

so,

$$I_y = (0.25 + 0.25 + 0.25) \text{ mA}$$

$$I_x = (0.25 + 0.25) \text{ mA}$$

$$I_x + I_y = (0.25) 5 \text{ mA}$$

$$= 1.25 \text{ mA}$$

■■■■





Detailed Explanation of Try Yourself Questions

T1. (a)

If $V_D = V_G$ \therefore we conclude that each MOSFET is in saturation.

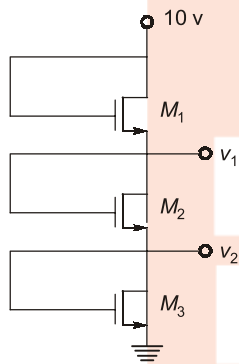

MOSFET M_1

$$I_D = k_{n1} (V_{GS} - V_T)^2$$

$$I_D = k_{n1} (V_{GS1} - V_T)^2$$

$$V_{GS1} = 10 - 5 = 5 \text{ v}$$

$$0.5 \text{ mA} = 36\mu \times \frac{1}{2} \cdot \left(\frac{W}{L}\right) \times (5 - 1)^2$$

$$\left(\frac{W}{L}\right)_1 = 1.73$$

MOSFET M_2

$$I_D = k_{n2} (V_{GS2} - V_T)^2$$

$$0.5 \text{ mA} = 36\mu \times \frac{1}{2} \left(\frac{W}{L}\right)_2 (3 - 1)^2$$

$$\left(\frac{W}{L}\right)_2 = 6.94$$

MOSFET M_3

$$I_D = k_{n3} (V_{GS3} - V_T)^2$$

$$0.5 \text{ mA} = 36\mu \times \frac{1}{2} \left(\frac{W}{L}\right)_3 (2 - 1)^2$$

$$\left(\frac{W}{L}\right)_3 = 27.8$$

T2. (a)

To calculate the value of V_{DS} , we require the voltage of both drain and source terminal.

Now, assuming the transistor to be in saturation region, the value of V_{GS} can be calculated as

$$I_D = \frac{\mu_n C_{ox} W}{2L} (V_{GS} - V_T)^2$$

$$1 \times 10^{-3} = 0.5 \times 10^{-3} \times (V_{GS} - V_T)^2$$

$$\sqrt{2} + 1.2 = V_{GS}$$

$$V_{GS} = 1.414 + 1.2$$

$$V_{GS} = 2.614 \text{ V}$$

Now, $V_{GS} = V_G - V_S$

$\therefore V_G = 0$

Thus $V_S = -2.614 \text{ V}$

And $V_D = 5 \text{ V}$

Thus, $V_{DS} = V_D - V_S = 5 - (-2.614)$

$$V_{DS} = 7.614 \text{ V}$$

$V_{DS} > V_{GS} - V_T$, so our assumption is correct.

T3. (c)

$$g_m = 2\sqrt{k_n I_D}$$

$$= 2\sqrt{10 \times 10^{-3} \times 10 \times 10^{-3}}$$

$$g_m = 20 \text{ mA/V}$$

now, drawing the T equivalent model, we have

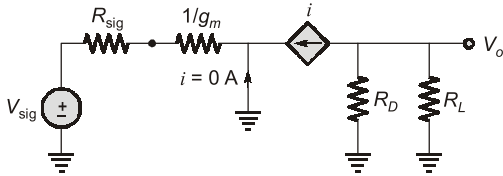

$$i = -\frac{V_{sig}}{\frac{1}{g_m} + R_{sig}}$$

and

$$V_{out} = \frac{(R_D \parallel R_L) \cdot V_{sig}}{\frac{1}{g_m} + R_{sig}}$$

$$V_{out} = \frac{g_m (R_D \parallel R_L) \cdot V_{sig}}{1 + g_m R_{sig}}$$

$$\therefore V_{out} = \frac{20 \times 10^{-3} (2 \times 10^3 \parallel 2 \times 10^3) \times 1 \times 10^{-3}}{1 + 20 \times 10^{-3} \times 50}$$

$$V_{out} = 10 \text{ mV}$$

T4. (b)

$$g_m = 2 \left[\frac{\mu_n C_{ox} W}{2L} \right] (V_{GS} - V_{TN})$$

or

$$g_m = 2 \sqrt{\frac{\mu_n C_{ox} W}{2L} \times I_{DQ}}$$

$$= 2 \sqrt{1 \times 10^{-3} \times 0.5 \times 10^{-3}}$$

$$= 1.414 \text{ mA/V}$$

Thus, considering small signal model, we get,

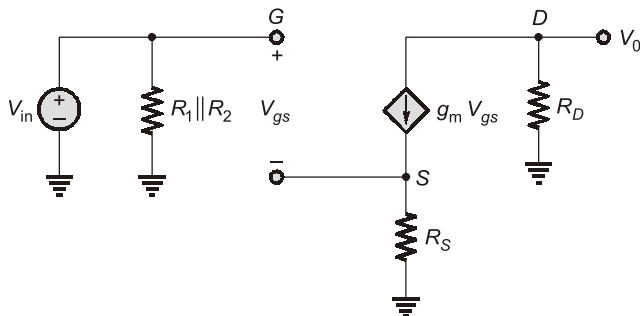

Thus,

$$V_o = -g_m V_{gs} R_D$$

$$V_{in} = V_{gs} + (g_m V_{gs}) R_S$$

$$V_{in} = V_{gs} (1 + g_m R_S)$$

$$A_v = \frac{V_o}{V_{in}} = \frac{-g_m R_D}{1 + g_m R_S}$$

$$A_v = \frac{-(1.414)(7)}{1 + (1.414)(0.5)} = -5.80$$

T5. (b)

By drawing the small signal equivalent circuit by deactivating all the D.C. supplies, we get,

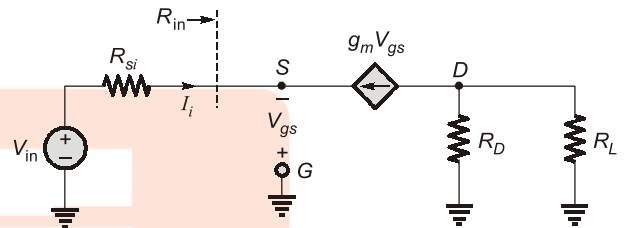

Now, from the figure,

$$R_{in} = \frac{-V_{gs}}{I_i}$$

and

$$I_i = -g_m V_{gs}$$

$$\therefore R_{in} = \frac{-V_{gs}}{-g_m V_{gs}} = \frac{1}{g_m}$$

T6. (a)

By drawing the small signal equivalent circuit, we get

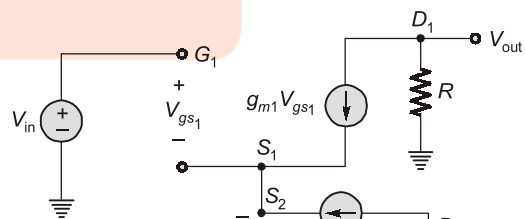

the above circuit can be redrawn as

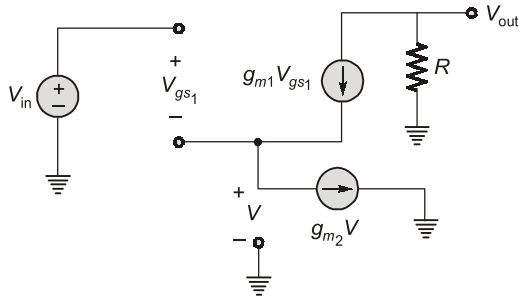

$$V_{out} = -g_{m1} R V_{in} + \frac{g_{m1} R V_{gs1}}{g_{m2}} \cdot g_{m1}$$

now from (3), we get

$$V_{out} = -g_{m1} R V_{in} - \frac{g_{m1}}{g_{m2}} V_{out}$$

$$\left(1 + \frac{g_{m1}}{g_{m2}}\right) V_{out} = -g_{m1} R V_{in}$$

$$V_{out} = \frac{-g_{m1} R}{1 + \frac{g_{m1}}{g_{m2}}} V_{in}$$

Substituting $V = -V_{gs2}$
now, $V_{in} = V_{gs1} + V$... (i)

and $g_{m1} V_{gs1} = g_{m2} \cdot V$
(\because from KCL at node S_1) ... (ii)

thus $V_{out} = -[g_{m1} V_{gs1} R]$... (iii)

$$V_{out} = -g_{m1} R (V_{in} - V) \quad \text{(from (i))}$$

$$= -g_{m1} R V_{in} + g_{m1} V R$$

now, $V = \frac{g_{m1} V_{gs1}}{g_{m2}}$ (from equation (ii))

$$\frac{V_{out}}{V_{in}} = \frac{-R}{\frac{1}{g_{m1}} + \frac{1}{g_{m2}}}$$

Hence, option (a) is correct.

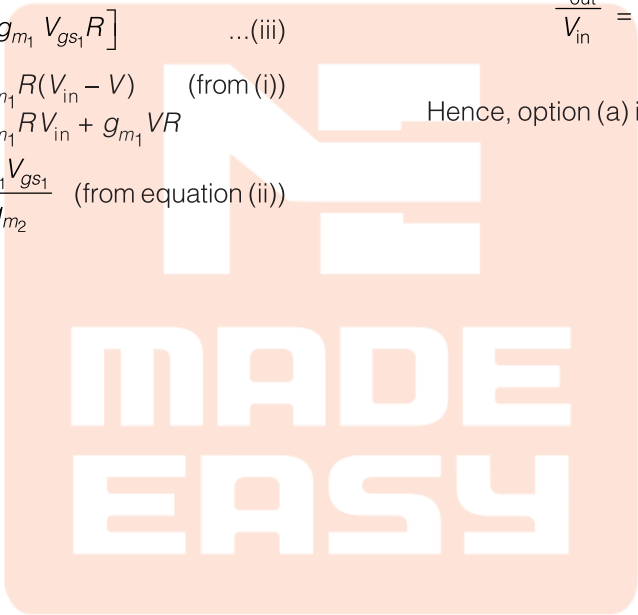

4

Multistage Amplifiers



Detailed Explanation of Try Yourself Questions

T1. (b)

The input resistance will be

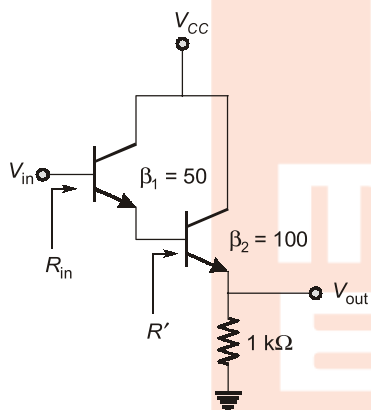

$$R' = r_{\pi} + (\beta_2 + 1)R_E$$
$$= 1\text{ k} + (101)(1\text{ k}) = 102\text{ k}\Omega$$

$$R_{in} = r_{\pi} + (\beta_1 + 1)R'$$
$$= 1\text{ k} + (51)(102\text{ k}) = 5.203\text{ M}\Omega$$



6

Application of Op-amp



Detailed Explanation of Try Yourself Questions

T1. (b)

Output of op-amp 1

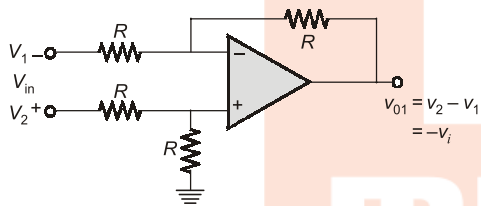

It is connected to schmitt trigger (inverting mode) → clockwise.
But inverting amplifier + inverting schmitt trigger
→ anticlockwise.

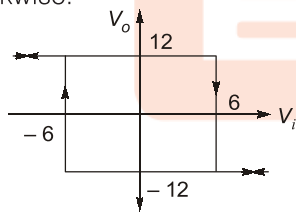

voltage shunt

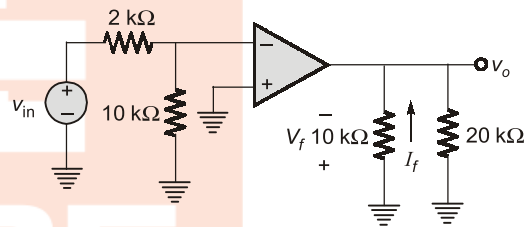

$$\beta = \frac{V_f}{V_o} = -1$$

$$\beta = \frac{I_f}{V_o} = -\frac{1}{10k}$$

$$|\beta| = \frac{1}{10k}$$

$$R_{if} = \frac{R_i}{A\beta} = \frac{10k}{10^5 \times \frac{1}{10k}}$$

$$= \frac{10 \times 10 \times 10^6}{10^5}$$

$$R_{if} = 1 \text{ k}\Omega$$

T2. (b)

$$R_{if} = \frac{R_i}{1 + A\beta} = \frac{R_i}{A\beta} \quad A\beta \gg 1$$

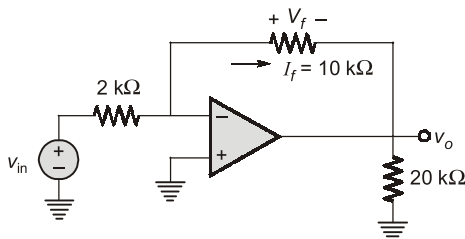

T3. (b)

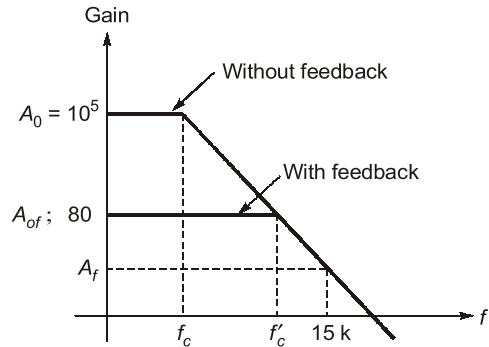
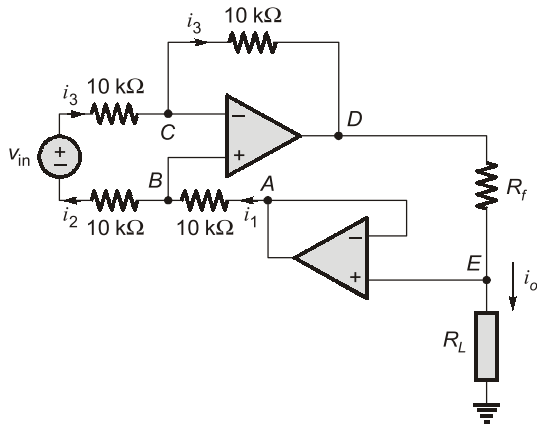

From the circuit,

$$V_E = i_o R_L$$

$$V_E = V_A \text{ (Virtual short concept)}$$

$$i_1 = i_2 = i_3$$

If we apply KVL between node B and C,

$$\therefore V_B = V_C \text{ (Virtual short concept)}$$

$$i_1 = i_2 = i_3 = \frac{V_{in}}{20 \text{ k}\Omega}$$

$$V_C - V_D = i_3 \times 10 \text{ k}\Omega = \frac{V_{in}}{2}$$

and $V_A - V_B = i_1 \times 10 \text{ k}\Omega = \frac{V_{in}}{2}$

$$\therefore V_B = V_C$$

$$\Rightarrow V_D - V_E = -V_{in}$$

$$\therefore i_o = \frac{-V_{in}}{R_f}$$

$$\bullet A_{of} = \frac{A_o}{1 + A_o \beta} \approx 80$$

$$\bullet f'_c = f_c(1 + A_o \beta) = 8 \left(1 + \frac{10^5}{80} \right) \text{ Hz} = 10,008 \text{ Hz}$$

• Gain at $f = 15 \text{ kHz} = 15000 \text{ Hz}$ is,

$$A_f = \frac{A_{of}}{\sqrt{1 + \left(\frac{f}{f'_c} \right)^2}}$$

$$= \frac{80}{\sqrt{1 + \left(\frac{15000}{10008} \right)^2}} \approx 44.4$$

T4. (44.4)

• In the given circuit,

$$\text{Feedback factor, } \beta = \frac{R_1}{R_1 + R_2} = \frac{1}{80}$$

T5. (0.6)

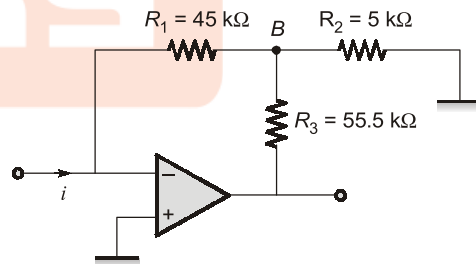

$$V_A = 0 \text{ (By virtual ground)}$$

$$\frac{V_B - 0}{45} + \frac{V_B - V_o}{55.5} + \frac{V_B - 0}{5} = 0$$

$$i = \frac{-(V_B - 0)}{45}$$

$$\therefore V_B = -45 i$$

$$\frac{-45 i}{45} + \frac{(-45 i) - V_o}{55.5} + \frac{(-45 i)}{5} = 0$$

$$-i - \frac{45i + V_o}{55.5} - 9i = 0$$

$$10i = -\frac{45i + V_o}{55.5}$$

$$600i = V_o$$

$$\frac{V_o}{i} = 600 \text{ k}\Omega = 0.6 \text{ M}\Omega$$

T6. (-2.5)

$$\frac{V_{in} - 0}{R} = 0 + I_C$$

$$\frac{V_{in}}{R} = C \frac{dV_C}{dt} = C \frac{d}{dt}(0 - V_{out})$$

$$-\frac{V_{in}}{RC} = \frac{dV_{out}}{dt}$$

$$V_{out} = \frac{-1}{RC} \int V_{in} dt$$

$$V_{out} =$$

$$\frac{-1}{10^3 \times 2 \times 10^{-6}} \int V_{in} dt$$

0 < t < 1 ms :

$$V_{in} = 5 \text{ volt}$$

$$V_{out} = -\frac{10^3}{2} \times 5(t)$$

at t = 1 ms

$$V_{out} = -10^3 \times 2.5 \times 1 \times 10^{-3}$$

3

$$= -2.5 \text{ volt}$$

1 ms < t < 2 ms:

$$V_{in} = 0 \text{ volt}$$

$$V_{out} = -2.5 \text{ volt}$$

∴ at t = 2 ms, V_{out} = -2.5 volt

T7. (a)

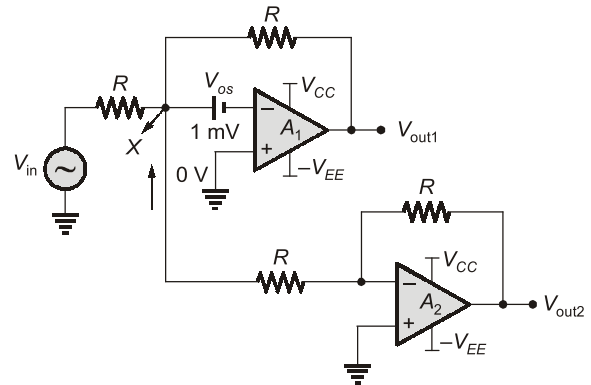

⇒ applying KCL at node X—

$$\frac{1}{2} + \frac{1 - V_{01}}{R} + \frac{1 - 0}{R} = 0$$

$$V_{01} = 3 \text{ mV}$$

$$V_{out2} =$$

and

$$1 \times \left(\frac{-R}{R} \right) = -1 \text{ mV}$$

T8. 15.39

$$V_{out} = \frac{-10^3}{2} \int V_{in} dt \text{ Volt}$$

$$f = \frac{1}{2\pi RC} = \frac{1}{2 \times 22 \times 10^3 \times 0.47 \times 10^6} = 15.39 \text{ Hz}$$

T9. 8.109

$$V_{sat} = 5 \text{ V}, \text{ UTP} = 3 \text{ V}, \text{ LTP} = 2 \text{ V}$$

$$v_c(t) = V_{final} + (V_{initial} - V_{final}) e^{-t/\tau}$$

$$\therefore \text{UTP} = V_{sat} + (LTP - V_{sat}) e^{-T_1/RC}$$

$$e^{-T_1/RC} = \left[\frac{V_{sat} - \text{UTP}}{V_{sat} - \text{LTP}} \right]$$

$$\therefore \text{Total, } T = 2T_1 = 2RC \ln \left[\frac{5-2}{5-3} \right]$$

$$\therefore T = 8.109 \text{ m-sec.}$$



7

Negative Feedback Amplifiers



Detailed Explanation of Try Yourself Questions

T1. (a)

The overall forward gain is 1000 and close loop gain is 100. Thus, $\beta = 0.009$.

Now, when gain of each stage increase by 10% then overall forward gain will be 1331 and using the previous value of β the close loop will be 102.55.

⇒ Close loop Voltage gain increase by 2.55%.

T2. (b)

The feedback element is R_f , it samples voltage and mix current so shunt-shunt feedback.



MADE EASY

8

Oscillators



Detailed Explanation of Try Yourself Questions

T1. (a)

The output can be $\pm 12\text{ V}$ only, when output is 12 V then

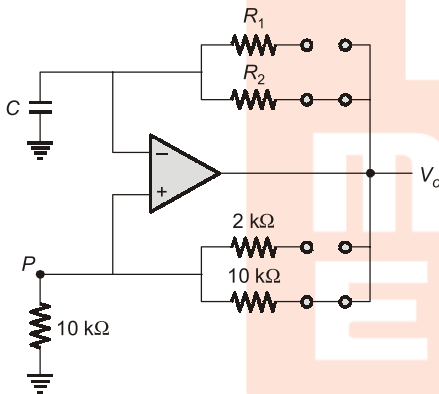

So, $V_p = 6\text{ V}$
when output is -12 V then

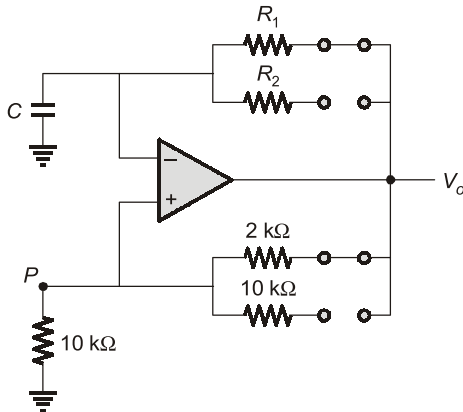

So, $V_p = -10\text{ V}$

T2. (d)

Since there are 3 capacitors the maximum phase shift that can be provided will be 270° but due to the presence of the RC circuit the phase shift is equal to 60° for the individual RC circuit, making the phase shift of the feedback network equal to 180° . Thus the amplifier should be an inverting amplifier so that it can be a positive feedback circuit and because the amplifier is a practical amplifier thus $|A\beta| > 1$ for the circuit to work.

