

**ESE**

**GATE**

**State Engg. Exams**

**MADE EASY**  
**WORKBOOK 2027**



**Detailed Explanations of  
Try Yourself Questions**

---

**Mechanical Engineering**  
Power Plant Engineering



# 1

## Gas Turbine and Gas Power Cycle



### Detailed Explanation of Try Yourself Questions

#### T1 : Solution

$\eta_{th} = \eta_{ericsson} = \eta_{carnot}$   
(for many stages of compression and expansion)

$\therefore$

$$\begin{aligned}\eta_{carnot} &= 1 - \frac{T_{Lavg}}{T_{Havg}} \\ &= \left(1 - \frac{290}{1200}\right) \times 100\% \\ &= 75.83\%\end{aligned}$$

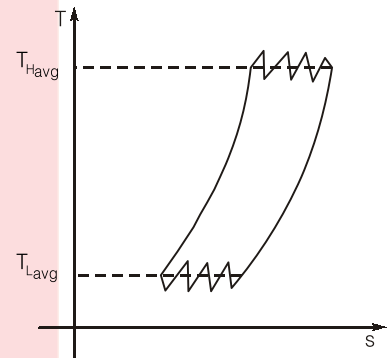

#### T2 : Solution

$\Rightarrow$

$\therefore$

$\Rightarrow$

and

Now,

$$W_{net} = W_T - W_C = 150$$

$$\frac{W_C}{W_T} = 0.4$$

$$W_C = 0.4 W_T$$

$$0.6 W_T = 150$$

$$W_T = 250 \text{ kJ/kg}$$

$$W_C = 250 - 150 = 100 \text{ kJ/kg}$$

$$W_{net actual} = \eta_T W_T - \frac{W_C}{\eta_C}$$

$$= 0.85 \times 250 - \frac{100}{0.85}$$

$$= 94.853 \text{ kJ/kg}$$

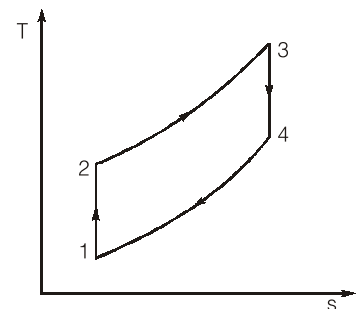

**T3 : Solution**

$$\begin{aligned}(W_{\text{net}})_{\text{max}} &= ? \\ T_{\text{max}} &= 800^{\circ}\text{C} = 1073 \text{ K} \\ T_{\text{min}} &= 30^{\circ}\text{C} = 303 \text{ K}\end{aligned}$$

Now,

$$\begin{aligned}(W_{\text{net}})_{\text{max}} &= c_p (\sqrt{T_{\text{max}}} - \sqrt{T_{\text{min}}})^2 \\ &= 1.005 (\sqrt{1073} - \sqrt{303})^2 = 236.794 \text{ kJ/kg}\end{aligned}$$

■■■■



# 2

## Steam Power Cycle & Steam Turbine



### Detailed Explanation of Try Yourself Questions

#### T1 : Solution

Given,

$$P_6 = 10 \text{ kPa}$$

$$x_6 = 1 - 0.104 = 0.896$$

Now,

$$s_6 = s_f + x_6 \times s_{fg6}$$

$$= 0.6492 + 0.896 \times 7.4996$$

$$= 7.3688 \text{ kJ/kg-K}$$

Now,

$$s_5 = s_6$$

$$s_6 = 7.3688 \text{ kJ/kg-K}$$

$$T = 600^\circ\text{C}$$

At

At

By interpolation,

$$\frac{7.3688 - 7.3127}{7.7306 - 7.3127} = \frac{P - 4}{4.5 - 4.0}$$

$$P = 4.067 \text{ MPa}$$

Max. reheat pressure possible is 4.067 MPa

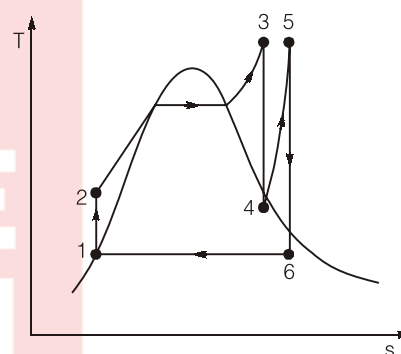

#### T2 : Solution

$$h_1 = 3625.3 \text{ kJ/kg}$$

$$s_1 = s_2$$

$$6.9029 = s_{i2} + x_2 s_{ig2}$$

$$6.9029 = 0.5725 + x_2(7.6845)$$

⇒

$$x_2 = 0.82378$$

∴

$$h_2 = h_{i2} + x_2 (h_{ig2})$$

$$= 167.57 + 0.82378 (2406.7) = 2150.16 \text{ kJ/kg}$$

Now, steam rate ( $\dot{m}_s$ ) =  $\frac{1}{(h_1 - h_2) - (h_4 - h_3)}$

$$= \frac{1}{3625.3 - 2150.16 - 10.06} = \frac{1}{1465.08}$$

$$= 6.825 \times 10^{-4} \text{ kg/kWs}$$

**T3 : Solution**

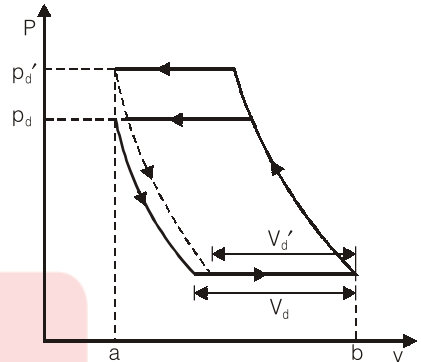
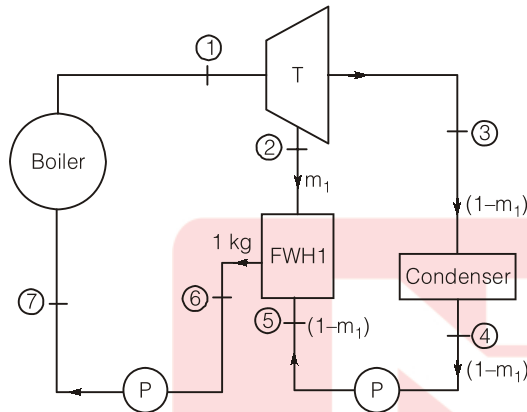

Enthalpy of feedwater,  $h_5 = 252 \text{ kJ/kg}$   
 Enthalpy of extracted steam,  $h_2 = 2810 \text{ kJ/kg}$   
 $h_6 = (h_f)_{2\text{MPa}} = 908.47 \text{ kJ/kg}$

$$m_1 h_2 + (1 - m_1) h_5 = 1 \cdot h_6$$

$$m_1 \times 2810 + (1 - m_1) \times 252 = 1 \times 908.47$$

$$\Rightarrow 2558 m_1 = 656.47$$

$$\Rightarrow m_1 = 25.66\% \approx 26\%$$

**T4 : Solution**

Given,  $h_3 = 2622.22$   
 $h_5 = 188.39$   
 $h_7 = 640.23$   
 $h_7 = m h_3 + (1 - m) h_5$

$$\Rightarrow 1 \times 640.23 = m \times 2622.22 + (1 - m) \times 188.39$$

$$\Rightarrow m = \frac{h_7 - h_5}{h_3 - h_5} = \frac{640.23 - 188.44}{2622.22 - 188.44}$$

$$= 0.18856 \text{ kg/s}$$

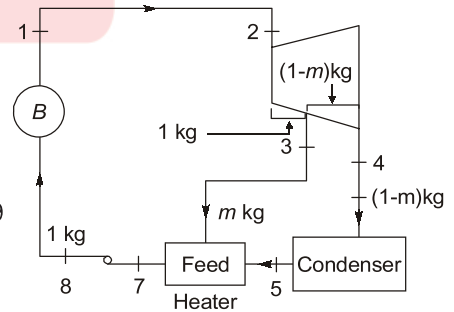



# 3

## Air Compressor



### Detailed Explanation of Try Yourself Questions

#### T1 : Solution

**Compressor stall:** When the compressor blades cannot process the amount of air coming from the engine inlet (and the stator vanes as well) the compressor of turbine engines “stall” – this translates generally by a very noisy explosion outside of the airplane and a flame that scares everyone around the aircraft. The blades of compressors are airfoils and every airfoil can be stalled that is when the angle of attack of the incoming air is too steep to be handled by the compressor. To prevent compressor stalls, engines, have variable inlet guide vanes to direct the incoming air at a better angle.

Aspect of Comparison	Axial Flow Compressors	Centrifugal Compressors
Type of flow	Parallel to the axis	Radial
Pressure ratio/stage	About 1.25	5
Isentropic efficiency	Higher (86 to 88%)	Lower (80 to 82%)
Frontal area	Smaller	Larger
Flexibility of operation	Limited	Higher
Part load performance	Poor	Better
Effect of deposits	Adverse effect	No adverse effect
Starting torque	High	Low
Suitability for multi staging	More Suitable	Difficult
Delivery Pressure	Lower (20 bar)	Higher (about 40 bar)
Efficiency with respect to speed	Less flat	More flat

#### T2 : Solution

Volumetric Efficiency of a compressor is defined as the ratio of Free Air Delivered (FAD) to the swept volume. FAD is the volume of air delivered by the compressor measured at some reference condition (which may be the ambient condition or the standard sea level condition). FAD is less than the swept volume due to the following reasons:

- (i) Throttling and pressure drop at inlet valve and passages;
- (ii) Heating of inlet air by coming in contact with hot cylinder walls; and

(iii) Re-expansion of compressed air retained in the clearance volume.

Effect of parameters on volumetric efficiency:

- (i) **Speed of compressor:** As the speed is increased the pressure drop in the inlet passage and the inlet valve increases. Further the air temperature during intake also increases due to less available for cooling. Both of these factors reduce volumetric efficiency of compressor with increase of its speed.
- (ii) **Delivery pressure:** Refer figure with increase of delivery pressure the pressure ratio increases and hence during inward stroke a-b, the effective swept volume is reduced. The volume of air delivered (FAD) is reduced from  $p_d$  to  $p_d'$ . Thus the volumetric efficiency is decreased when pressure is increased.
- (iii) **Throttling across the valves:** Throttling across the inlet valve reduces the pressure in the cylinder at the end of the inlet stroke. Further, throttling at the inlet and delivery valves increases the pressure ratio. Both of these effects would reduce the FAD, and hence the volumetric efficiency of the compressor.

### T3 : Solution

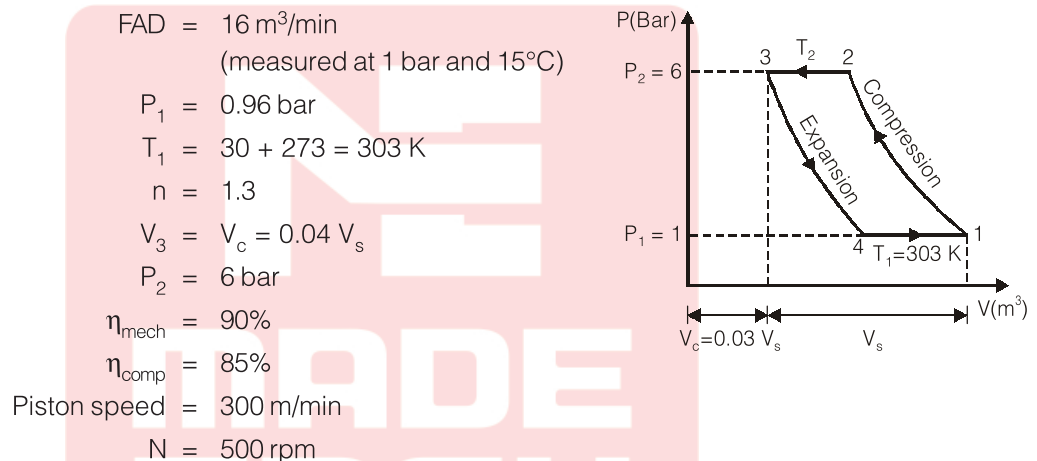

(i) **Power input to compressor:** Mass flow rate of compressor

$$m = \frac{pV}{RT} = \frac{(1 \times 10^5) \times 16}{287 \times 288} = 19.36 \text{ kg/min}$$

[where FAD per minute is  $V$  at  $p$  (= 1 bar) and  $T$  (15 + 273 = 288 K)]

To find  $T_2$ , using the equation

$$\frac{T_2}{T_1} = \left( \frac{p_2}{p_1} \right)^{\frac{n-1}{n}}$$

$$\therefore T_2 = T_1 \times \left( \frac{p_2}{p_1} \right)^{\frac{n-1}{n}} = 303 \times \left( \frac{6}{0.96} \right)^{\frac{1.3-1}{1.3}} = 462.4 \text{ K}$$

Power input to compressor

$$\begin{aligned}
 &= \left[ \frac{n}{n-1} mR(T_2 - T_1) \right] \times \frac{1}{\eta_{\text{mech.}} \times \eta_{\text{comp.}}} \\
 &= \left[ \left( \frac{1.3}{1.3-1} \right) \times 19.36 \times 0.287(462.4 - 303) \right] \times \frac{1}{0.9 \times 0.85} \\
 &= 5016.9 \text{ kJ/min.} = 83.6 \text{ kJ/s (kW)}
 \end{aligned}$$

(ii) We know,

$$\eta_{vol} = 1 + C - C \left( \frac{P_2}{P_1} \right)^{\frac{1}{n}}$$

$$= 1 + 0.04 - 0.04 \left( \frac{6}{0.96} \right)^{\frac{1}{1.3}} = 0.8762$$

$$\frac{P_1 \dot{V}_1}{T_1} = \left( \frac{P \dot{V}}{T} \right)_{FAD}$$

$$\frac{0.96 \times \dot{V}_1}{303} = \frac{1 \times 16}{288} \Rightarrow \dot{V}_1 = 17.534 \text{ m}^3/\text{min}$$

Piston speed =  $2LN = 300$

$$2 \times L \times 500 = 300 \Rightarrow L = 0.3 \text{ m}$$

$$\eta_{vol} = \frac{\dot{V}_1}{\frac{\pi}{4} \times D^2 L (2N)}$$

$$D^2 = \frac{\dot{V}_1 \times 4}{(\eta_{vol}) \pi \times L \times (2N)}$$

$$D = \sqrt{\frac{17.534 \times 4}{0.8762 \times \pi \times 0.3 \times 2 \times 500}} = 291.43 \text{ mm}$$

Double acting

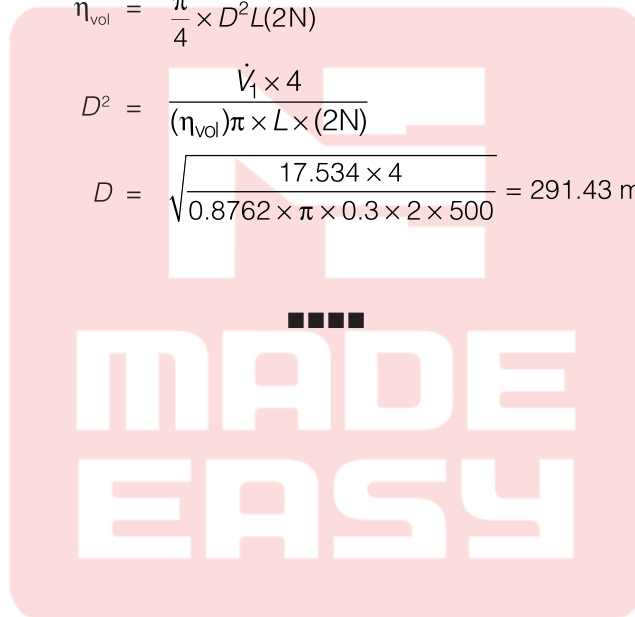

# 5

## Boilers and Condenser



### Detailed Explanation of Try Yourself Questions

#### T1 : Solution

- (i) **LaMont Boiler:** This boiler works on a forced circulation and the circulation is maintained by a centrifugal pump, driven by a steam turbine using steam from the boiler. The following figure shows a LaMont boiler. The feed water passes through the economiser to the drum from which it is drawn to the circulation pump. The pump delivers the feed water to the tube evaporating section which in turn sends a mixture of steam and water to the drum. The steam in the drum is then drawn through the superheater. These boilers have been built to generate 45 to 50 t of superheated steam at 130 bar and 500°C.

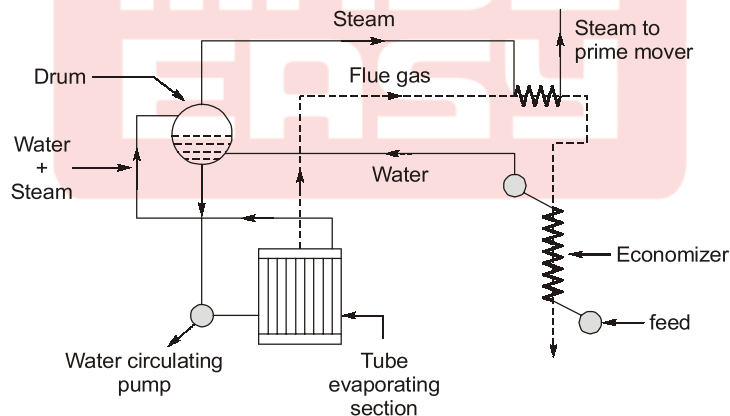

La Mont Boiler

- (ii) **Velox Boiler:** Velox boiler makes use of pressurised combustion. The gas turbine drives the axial flow compressor which raises the pressure of incoming air from atmospheric pressure to furnace pressure. The combustion gases after heating the water and steam, flow, through the gas turbine to the atmosphere. The feed water after passing through the economiser is pumped by a water circulating pump to the tube evaporating section. Steam separated in steam separating section flows to the superheater, from where it moves to the prime mover.

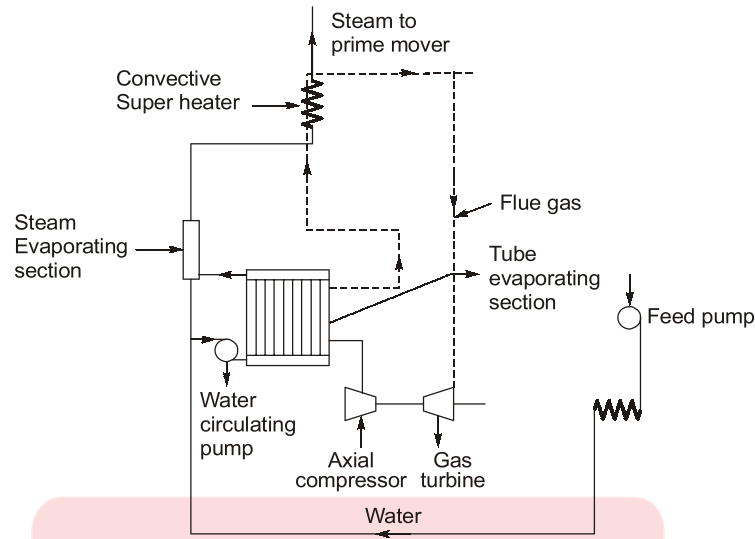

**Velox Boiler**

The size of the velox boiler is limited to 100 t/h because 600 BHP is required to run the air compressor at this output.

Advantage of velox boiler:

- (i) The boiler is very compact and greater flexibility.
- (ii) Very high combustion rates are possible.
- (iii) It can be quickly started.
- (iv) Low excess air is required as the pressurised air is used and the problem of draught is simplified.

**T2 : Solution**

For small steam requirements, fire tube boilers are suitable. Fire tube boilers have different characteristic feature as follows:

- Low initial cost
- Reliability in operation
- Need for only unskilled labour
- Less draught required
- Quick response to load change
- Compact in size

Fire Tube Boilers	Water Tube Boilers
1. Hot flue gases flow through tubes surrounded by water in a shell.	1. Water flows through the tubes and hot flue gases flow over them.
2. Subjected to large scale deposits.	2. Less scale deposits.
3. Smaller steaming capacity.	3. Higher steaming capacity.
4. Relatively larger drum size.	4. Smaller drum size.

**T3 : Solution**

**Benson Boiler:** In the LaMont boiler, the main difficulty experienced is the formation and attachment of bubbles on the inner surfaces of the heating tubes. The attached bubbles to the tube surfaces reduce the heat flow and steam generation as it offers high thermal resistance than water film. Benson in 1922 argued that if the boiler pressure was raised to critical pressure (225 atm.), the steam and water have the same density and therefore, the danger of bubble formation can be easily eliminated. The first high pressure Benson boiler was put into operation in 1927 in West Germany.

This boiler too makes use of forced circulation and uses oil as fuel. Chief novel principle is that it eliminates the latent heat of water by first compressing the feed to a pressure of 235 bar, it is then above the critical pressure and its latent heat is zero.

Figure shows a schematic diagram of a Benson boiler. This boiler does not use any drum. The feed water after circulation through the economiser tubes flows through the radiant parallel tube section to evaporate partly. The steam water mixture produced then moves to the transit section where this mixture is converted into steam. The steam is now passed through the convection superheater and finally supplied to the prime mover.

Boilers having as high as 650°C temperature of steam had been put into service. The maximum working pressure obtained so far from commercial Benson boiler is 500 atm. The Benson boilers of 150 tonnes/h generating capacity are in use.

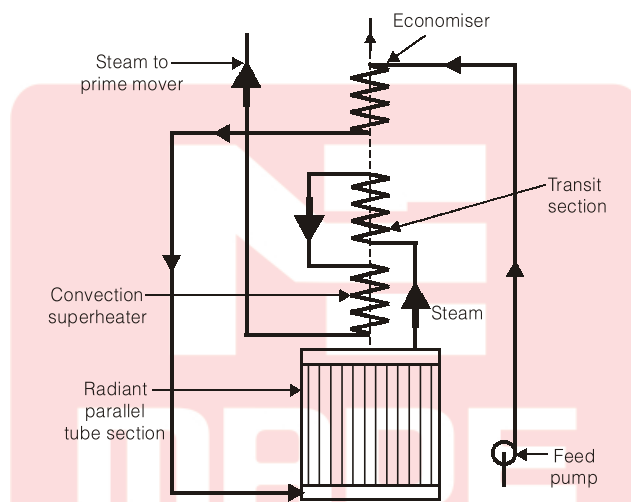

### Advantages of a Benson Boiler

The Benson boiler possesses the following advantages:

1. It can be erected in a comparatively smaller floor area.
2. The total weight of a Benson boiler is 20% less than other boilers, since there are no drums. This also reduces the cost of the boiler.
3. It can be started very quickly because of welded joints.
4. Natural convection boilers require expansion joints but these are not required for Benson boiler as the pipes are tubes.
5. The furnace walls of the boiler can be more efficiently protected by using smaller diameter and closed pitched tubes.

