



**MADE EASY**

Leading Institute for ESE, GATE & PSUs

# ESE 2026 : Mains Test Series

UPSC ENGINEERING SERVICES EXAMINATION

## Electronics & Telecommunication Engineering

Test-3 : Analog and Digital Communication Systems [All topics]

Digital Circuit-1 + Microprocessors and Microcontroller [Part Syllabus]

Network Theory-2 + Signals and Systems-2 [Part Syllabus]

Name : .....

Roll No :

Test Centres	Student's Signature
Delhi <input type="checkbox"/> Bhopal <input type="checkbox"/> Jaipur <input type="checkbox"/> Pune <input type="checkbox"/> Hyderabad <input type="checkbox"/>	

- Instructions for Candidates**
- Do furnish the appropriate details in the answer sheet (viz. Name & Roll No).
  - There are Eight questions divided in TWO sections.
  - Candidate has to attempt FIVE questions in all in English only.
  - Question no. 1 and 5 are compulsory and out of the remaining THREE are to be attempted choosing at least ONE question from each section.
  - Use only black/blue pen.
  - The space limit for every part of the question is specified in this Question Cum Answer Booklet. Candidate should write the answer in the space provided.
  - Any page or portion of the page left blank in the Question Cum Answer Booklet must be clearly struck off.
  - There are few rough work sheets at the end of this booklet. Strike off these pages after completion of the examination.

FOR OFFICE USE	
Question No.	Marks Obtained
Section-A	
Q.1	<del>40</del> 38
Q.2	-
Q.3	34
Q.4	19
Section-B	
Q.5	29
Q.6	30
Q.7	-
Q.8	-
<b>Total Marks Obtained</b>	<b>150</b>

Signature of Evaluator Cross Checked by

*(Signature)* .....

6/4/26

- Keep it up -

- Avoid Silly mistakes -

## IMPORTANT INSTRUCTIONS

**CANDIDATES SHOULD READ THE UNDERMENTIONED INSTRUCTIONS CAREFULLY. VIOLATION OF ANY OF THE INSTRUCTIONS MAY LEAD TO PENALTY.**

### DONT'S

1. Do not write your name or registration number anywhere inside this Question-cum-Answer Booklet (QCAB).
2. Do not write anything other than the actual answers to the questions anywhere inside your QCAB.
3. Do not tear off any leaves from your QCAB, if you find any page missing do not fail to notify the supervisor/invigilator.
4. Do not leave behind your QCAB on your table unattended, it should be handed over to the invigilator after conclusion of the exam.

### DO'S

1. Read the Instructions on the cover page and strictly follow them.
2. Write your registration number and other particulars, in the space provided on the cover of QCAB.
3. Write legibly and neatly.
4. For rough notes or calculation, the last two blank pages of this booklet should be used. The rough notes should be crossed through afterwards.
5. If you wish to cancel any work, draw your pen through it or write "Cancelled" across it, otherwise it may be evaluated.
6. Handover your QCAB personally to the invigilator before leaving the examination hall.

Section A : Analog and Digital Communication Systems

1 (a) (i) A Double sideband suppressed carrier (DSB-SC) signal is defined as  $s(t) = A \cos(\omega_c t) m(t)$ , where  $m(t)$  is the message signal with average power  $P_m$ . The signal is applied to a coherent detector where the local oscillator has a phase error of  $30^\circ$ , represented by  $c(t) = A \cos(\omega_c t + 30^\circ)$ .

Assuming the output is passed through an ideal Low Pass Filter (LPF) with a bandwidth equal to that of the message signal.

1. Derive the expression for the output signal  $y(t)$ .
2. Determine the average power of the output signal  $y(t)$  in terms of  $A$  and  $P_m$ .

(ii) A coherent BFSK system uses the following signalling waveforms:

$s_0(t) = \cos(2\pi f_0 t); 0 \leq t \leq T_b \Rightarrow$  for logic 0

$s_1(t) = \cos(2\pi f_1 t); 0 \leq t \leq T_b \Rightarrow$  for logic 1

The frequencies are given as  $f_0 = 1000$  kHz and  $f_1 = 1050$  kHz.

1. Calculate the maximum possible bit rate ( $R_b$ ) such that the signals remain orthogonal.
2. If the bit rate is increased to 200 kbps, determine the minimum frequency  $f_1$  required to maintain the orthogonality between signals.
3. Calculate the transmission bandwidth (B.W) of this BFSK system for the bit rate found in part (1), using the first-null criteria.

[6 + 6 marks]

Q.1(a) A Double sideband suppressed carrier is given by,

$s(t) = A \cos(\omega_c t) m(t)$

$c(t) = A \cos(\omega_c t + 30^\circ)$

(b)  
Good

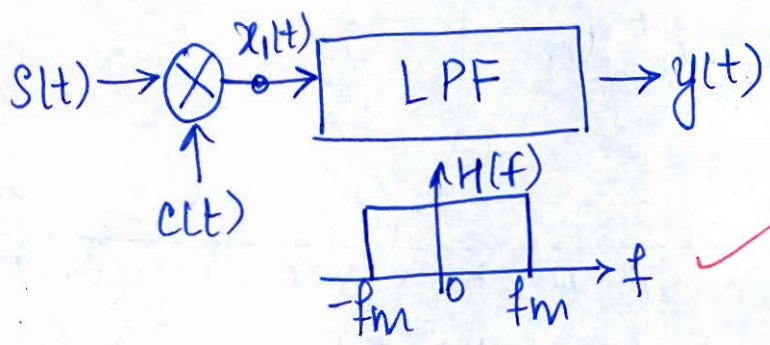

$x_1(t) = s(t) \cdot c(t)$

$$x_1(t) = [A \cos(\omega_c t) m(t)] \cdot A \cos(\omega_c t + 30^\circ)$$

$$x_1(t) = A^2 m(t) \frac{2}{2} \cos \omega_c t \cos(\omega_c t + 30^\circ)$$

$$2 \cos A \cos B = \cos(A-B) + \cos(A+B)$$

$$\therefore x_1(t) = \frac{A^2 m(t)}{2} [\cos(\omega_c t - \omega_c t - 30^\circ) + \cos(2\omega_c t + 30^\circ)]$$

$$\therefore x_1(t) = \frac{A^2 m(t)}{2} [\cos 30^\circ + \cos(2\omega_c t + 30^\circ)]$$

After passing through LPF of BW of message signal,

$$y(t) = \frac{A^2 m(t) \cos 30^\circ}{2}$$

$$y(t) = \frac{A^2}{2} \times \frac{\sqrt{3}}{2} m(t) \Rightarrow y(t) = \frac{\sqrt{3}}{4} A^2 m(t)$$

Q.1(a)(i) (2):  $m(t)$  is the message signal with average power  $P_m$ .

$$\therefore P_y = \left[ \frac{\sqrt{3}}{4} A^2 m(t) \right]^2$$

$$\therefore P_y = \frac{3}{16} A^4 P_m$$

Q.1(a)(ii) A coherent BFSK system is given:

$$\text{with } f_0 = 1000 \text{ KHz}$$

$$f_1 = 1050 \text{ KHz}$$

1. Maximum possible bit rate ( $R_b$ ) such that signal remains orthogonal.

$$f_1 - f_0 = \frac{mR_b}{2}$$

for  $m=1$

$$\therefore 50 = \frac{R_b}{2}$$

$$\text{or } R_b = 100 \text{ kbps}$$

2. If the bit rate is increased to 200 kbps.

i.e.  $R_b = 200 \text{ kbps}$

$$f_1 = ?$$

Since,  $f_1 - f_0 = \frac{R_b}{2}$

4

$$f_1 - 1000 = \frac{200}{2}$$

$$\therefore f_1 = \frac{200}{2} + 1000 = 1100 \text{ KHZ}$$

3. Transmission bandwidth of BFSK is

$$BW = f_1 - f_0 + \frac{R_b}{2} \rightarrow 2R_b$$

$$\therefore BW = 50 + \frac{100}{2}$$

$$\therefore BW = 100 \text{ KHZ}$$

- Q.1 (b)
- (i) Define the Shannon-Hartley theorem for channel capacity. State the condition required for "error-free transmission" in a digital communication system.
  - (ii) A binary signal is transmitted through an ideal AWGN channel with infinite bandwidth. If the two-sided Power spectral density (PSD) of the channel noise is 7 mW/Hz:
    1. Derive the expression for the minimum bit energy ( $E_b$ ) required for error-free transmission as the bandwidth approaches infinity.
    2. Calculate the numerical value of this minimum average bit energy.

[2 + 6 + 4 marks]

soln:

Q.1 (b)(i)

Shannon Hartley theorem for channel capacity is given

$$C = B \log_2 \left( 1 + \frac{S}{N} \right)$$

where, B is Bandwidth

$\frac{S}{N}$  is signal to noise ratio

condition required for error free transmission is that

$$C \geq R_b$$

channel Bandwidth  $\geq$  signal Bandwidth

Q.1 (b)(ii) Given:

$$PSD, \frac{N_0}{2} = 7 \frac{mW}{Hz}$$

$$1. C = B \log_2 \left( 1 + \frac{S}{N} \right)$$

$$C = B \log_2 \left( 1 + \frac{E_b}{T_b \times N_0 B} \right)$$

where,  $S = \frac{E_b}{T_b}$

$$N = N_0 B$$

$$C = B \log_2 \left( 1 + \frac{E_b R_b}{N_0 B} \right)$$

for error free transmission:

$$C \geq R_b$$

$$\therefore B \log_2 \left( 1 + \frac{E_b R_b}{N_0 B} \right) \geq R_b$$

$$\log_2 \left( 1 + \frac{E_b R_b}{N_0 B} \right) \geq \frac{R_b}{B}$$

$$\therefore 1 + \frac{E_b R_b}{N_0 B} \geq 2^{\left( \frac{R_b}{B} \right)}$$

now,

$$\frac{E_b R_b}{N_0 B} \geq \left[ 2^{\frac{R_b}{B}} - 1 \right]$$

and,

$$E_b \geq \frac{N_0 B}{R_b} \left[ 2^{\frac{R_b}{B}} - 1 \right]$$

(1)

↓ incomplete soln



1 (c) A binary communication system uses two equiprobable signal  $s_0(t)$  and  $s_1(t)$ . The constellation diagram for these signals in a two-dimensional orthonormal signal space  $(\phi_1, \phi_2)$  is shown below. The signals are transmitted over an AWGN channel with a two-sided noise Power Spectral Density (PSD) of  $0.50 \text{ W/Hz}$ .

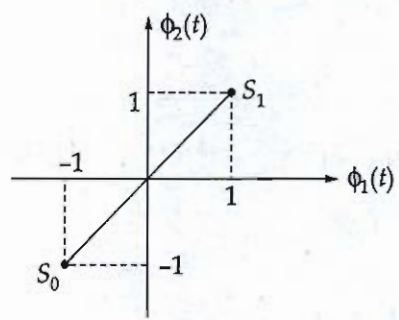

- (i) Identify the signal vector  $s_0$  and  $s_1$  from the diagram and calculate the distance of each signal point from the origin. What does this distance represent physically?
- (ii) Determine the minimum Euclidean distance ( $d_{\min}$ ) between the two symbols.
- (iii) Calculate the Bit Error Rate (BER) of the system using an optimum threshold correlator receiver. Express your result in terms of the  $Q$ -function.

[12 marks]

sol. (i) Given: PSD  $\frac{N_0}{2} = 0.50 \frac{\text{W}}{\text{Hz}}$

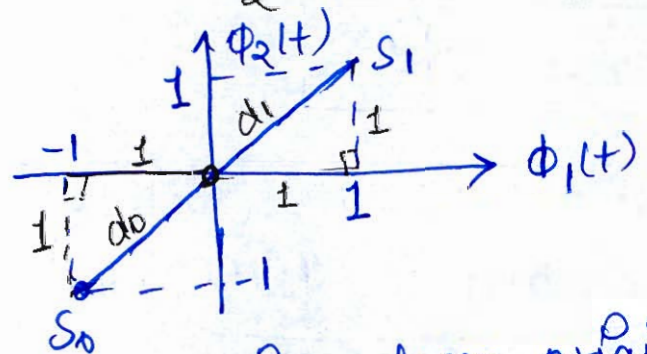

the distance of  $s_0$  point from origin,

$$d_0^2 = 1^2 + 1^2$$

$$\therefore d_0 = \sqrt{1^2 + 1^2} = \sqrt{2}$$

the distance of  $s_1$  point from origin,

$$d_1 = \sqrt{1^2 + 1^2}$$

$$d_1 = \sqrt{2}$$

Since  $d = \sqrt{E_b}$ , therefore, these distances physical represents the bit energy required by each constellation point.

Q.1(c) (ii) The minimum Euclidean distance  $d_{\min}$  is:

$$s_1 = \{1, 1\}$$

$$s_0 = \{-1, -1\}$$

$$\therefore d_{\min} = \sqrt{(1 - (-1))^2 + (1 - (-1))^2}$$

$$d_{\min} = \sqrt{2^2 + 2^2} = 2\sqrt{2}$$

$$\therefore \boxed{d_{\min} = 2\sqrt{2}}$$

Q.1(c) (iii) Bit error rate (BER) of the system is given by,

$$P_e = Q\left(\sqrt{\frac{d_{\min}^2}{2N_0}}\right)$$

where,  $d_{\min} = 2\sqrt{2}$

and,  $\frac{N_0}{2} = 0.50 \frac{W}{Hz}$

$$\therefore N_0 = 1 \frac{W}{Hz}$$

$$\therefore \boxed{P_e = Q\left(\sqrt{\frac{(2\sqrt{2})^2}{2 \times 1}}\right) = Q(2)}$$

12  
Good!



- 1 (d) (i) A sinusoidal message signal  $m(t) = A_m \cos(2\pi f_m t)$  is applied to the X-plates of of a CRO, and an AM signal  $s(t) = A_c [1 + \mu \cos(2\pi f_m t)] \cos(2\pi f_c t)$  is applied to the Y-plates. The resulting X-Y display is a triangle with a maximum vertical height of 4 units. The unmodulated carrier power is measured into an antenna load of 5 ohm.
1. Determine the modulation index ( $\mu$ ) from the given CRO display and identify the modulation state.
  2. If the peak amplitude of the message signal is 10 V, calculate the total power transmitted and the power stored in the sidebands for this specific triangular pattern.
  3. Calculate the Transmission efficiency ( $\eta$ ) of this AM signal. What is the maximum possible efficiency for a standard AM wave without over-modulation?
- (ii) Two random process,  $X(t)$  and  $Y(t)$  are related by a differentiation operation, such that  $Y(t) = \frac{dX(t)}{dt}$ . It is given that  $X(t)$  is real valued wide sense stationary (WSS) process with a known auto-correlation function (ACF) denoted by  $R_X(\tau)$ . Determine the exact expression for the ACF of the resulting process,  $R_Y(\tau)$ , expressed in terms of the derivatives of  $R_X(\tau)$ .

[6 + 6 marks]

Q.1(a)(i) 1.

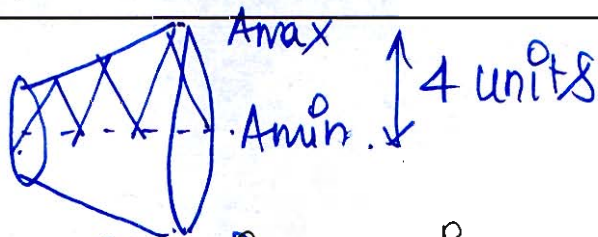

The x-y display is triangle with a maximum vertical height of 4 units.

i.e.  $A_{\max} - A_{\min} = 4$ . — (a)

$$A_{\max} = A_c (1 + \mu) \quad \text{--- (1)}$$

$$A_{\min} = A_c (1 - \mu) \quad \text{--- (2)}$$

Now, the carrier power is given by

$$P_c = ?$$

From (1) & (2) and (a)

$$A_{\max} - A_{\min} = A_c [1 + \mu] - A_c [1 - \mu]$$

$$4 = A_c + A_c \mu - A_c + A_c \mu$$

$$4 = 2A_c \mu$$

$$\therefore \mu = \frac{4}{2A_c}$$

Q. If peak amplitude of message signal is 10V.  $A_m = 10V$

$$\mu = k_a |m(t)|_{\max}$$

$$\mu = \frac{A_m}{A_c}$$

Q1 (d) (ii) Given:  $y(t) = \frac{dx(t)}{dt}$

$$x(t) \xrightarrow{ACF} R_x(\tau)$$

$$y(t) \xrightarrow{ACF} R_y(\tau)$$

Ans:  $R_x(\tau) = E[x(t)x(t+\tau)]$  ✓

$$R_y(\tau) = E[y(t)y(t+\tau)]$$

$$\therefore R_y(\tau) = E\left[\frac{dx(t)}{dt} \cdot \frac{dx(t+\tau)}{dt}\right]$$

$$R_y(\tau) = E\left[\frac{d^2x(t)x(t+\tau)}{dt^2}\right] ✓$$

$$\therefore R_y(\tau) = \frac{d^2}{dt^2} E[x(t)x(t+\tau)]$$

(4)

$$\therefore R_y(\tau) = -\frac{d^2}{dt^2} R_x(\tau)$$



- 1 (e) (i) The message signal  $m(t)$  shown in the figure is applied separately to a frequency modulator with frequency sensitivity  $k_f$  (in Hz/V) and a phase modulator with a phase sensitivity  $k_p$  (in rad/V).

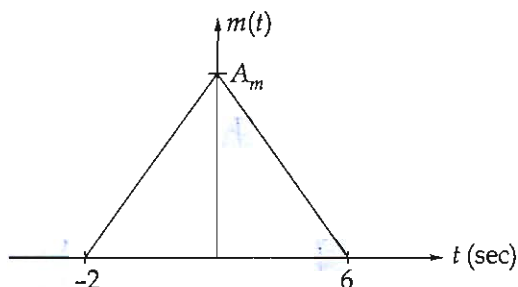

- Derive the expression for the instantaneous frequency in both FM and PM cases. And obtain the maximum frequency deviation  $(\Delta f)_{\max}$  for both FM and PM signals.
  - Sketch the waveform of  $\frac{dm(t)}{dt}$  versus  $t$  and determine its maximum absolute value i.e.,  $\left| \frac{dm(t)}{dt} \right|_{\max}$ .
  - If the maximum frequency deviation  $(\Delta f)_{\max}$  is kept the same in both cases, find the ratio  $\frac{k_p}{k_f}$ .
- (ii) An AM receiver is designed to receive signals with a carrier frequency ( $f_c$ ) in the range of 550 kHz to 1650 kHz. The receiver uses an intermediate frequency ( $f_{IF}$ ) of 450 kHz. The local oscillator frequency ( $f_{LO}$ ) is set at the higher of the two possible values for all incoming signals. A variable capacitor-based LC oscillator is used as the local oscillator.
- Determine the tuning range of the local oscillator.
  - Calculate the required capacitance ratio  $\left( \frac{C_{\max}}{C_{\min}} \right)$  for the local oscillator to cover this frequency range.
  - Explain the concept of "High-side Injection" and "Low-side Injection" in a superhetrodyne receiver. Why is high-side injection generally preferred in AM broadcast receivers?

[6 + 6 marks]

Q.1 (c) Given:

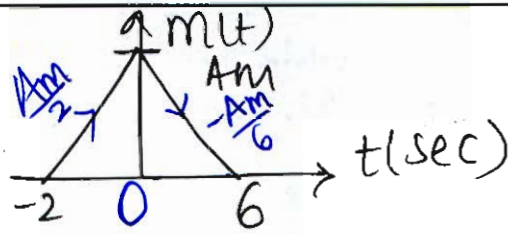

1. For FM:

$$s_{FM}(t) = A_c \cos \left( 2\pi f_c t + 2\pi k_f \int_{-\infty}^t m(t) dt \right)$$

$$\therefore \theta(t) = 2\pi f_c t + 2\pi k_f \int_{-\infty}^t m(t) dt$$

$$\therefore \omega(t) = \frac{d\theta(t)}{dt} = 2\pi f_c + 2\pi k_f m(t)$$

$$\therefore \boxed{f(t) = f_c + k_f m(t)}$$

Frequency deviation for FM

$$\Delta f|_{\max} = k_f |m(t)|_{\max}$$

$$\boxed{\Delta f|_{\max} = k_f \cdot A_m} \quad \text{--- (1)}$$

For PM

$$s_{PM}(t) = A_c \cos \left( 2\pi f_c t + k_p m(t) \right)$$

$$\therefore \theta(t) = 2\pi f_c t + k_p m(t)$$

$$\omega(t) = \frac{d\theta(t)}{dt} = 2\pi f_c + k_p \frac{dm(t)}{dt}$$

$$\therefore \boxed{f(t) = f_c + \frac{k_p}{2\pi} \frac{dm(t)}{dt}}$$

frequency deviation for PM:

$$\Delta f|_{\max} = \frac{k_p}{2\pi} \left| \frac{dm(t)}{dt} \right|_{\max}$$

$$\therefore \Delta f_{\max} = \frac{K_p}{2\pi} \times \frac{A_m}{6} = \frac{K_p A_m}{12\pi}$$

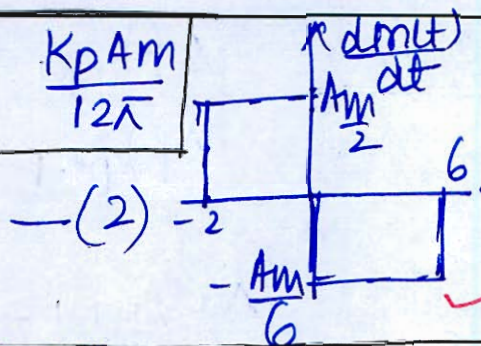

Q.1 (e) (i) (2)

~~1~~ ~~2~~ 3

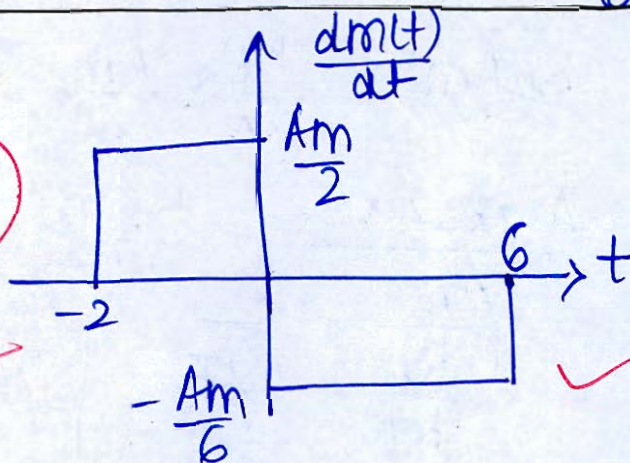

The  $\frac{dm(t)}{dt}$  graph is shown above.

Let  $P(t) = \frac{dm(t)}{dt}$

for maximum value, differentiate  $P(t)$  and equate it to zero.

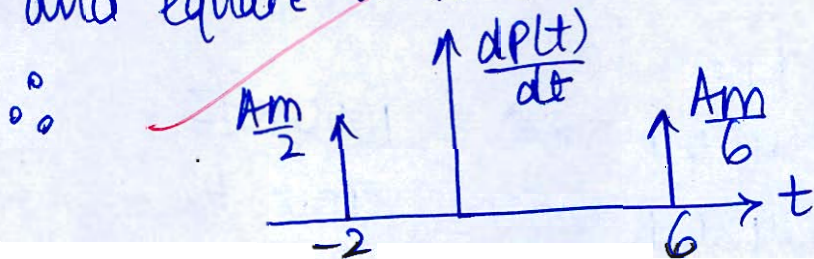

$\therefore$  The absolute maximum value of  $\left| \frac{dm(t)}{dt} \right|_{\max}$  occurs at  $t = 6$  sec and it is

$$\left| \frac{dm(t)}{dt} \right|_{\max} = \frac{A_m}{6}$$

Q.1(c)(i) 3.  $(\Delta f)_{FM} = k_f A_m$  from (1) & (2),  
 $(\Delta f)_{PM} = \frac{K_p}{2\pi} \times \frac{A_m}{6}$

$\therefore (\Delta f)_{FM} = (\Delta f)_{PM}$   
 $k_f A_m = \frac{K_p}{2\pi} \times \frac{A_m}{6}$

$\therefore \frac{A_m \times 2\pi \times 6}{A_m} = \frac{K_p}{k_f}$

$\therefore \frac{K_p}{k_f} = 12\pi$

Q.1(c)(ii) Given:  $f_{IF} = 450 \text{ KHz}$   
 $f_c = 550 \text{ KHz to } 1650 \text{ KHz}$   
 $f_{LO} = \text{local oscillator frequency}$

1.  $f_L - f_c = f_{IF}$

$\therefore f_L = f_{IF} + f_c$

$\therefore f_{L1} = 450 + 550 = 1000 \text{ KHz}$

$f_{L2} = 450 + 1650 = 2100 \text{ KHz}$

the tuning range of  $f_L$  is 1000 - 2100 KHz.

2.  $\frac{C_{max}}{C_{min}} = \frac{f_{min}^2}{f_{max}^2} = \frac{(550)^2}{(1650)^2} = 0.11$

3. High side injection is increasing the power level received through the antenna and low side injection is less preferred since, the signal is already amplified at local.

- 2 (a) Consider the SSB system shown below which transmits the lower sideband modulated signal  $s(t)$ .

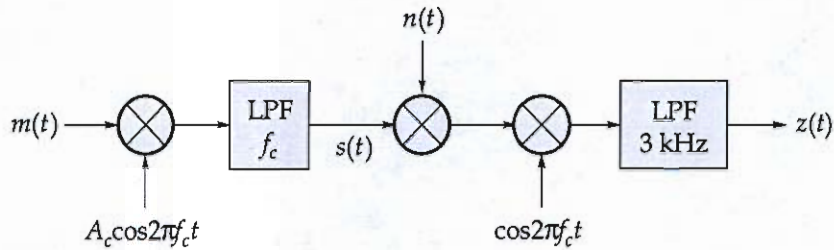

Assume that the message signal  $m(t)$  has PSD of  $|M(f)|^2$  and its Fourier transform

$$M(f) = \begin{cases} 0.003 & |f| \leq 1.5 \text{ kHz} \\ 0.001 & 1.5 \text{ kHz} \leq f \leq 3 \text{ kHz} \\ 0 & |f| > 3 \text{ kHz} \end{cases}$$

- (i) Find  $A_c$  such that the power in  $s(t)$  is equal to 100 mW. Also, draw the spectrum of  $m(t)$ ,  $s(t)$  and  $z(t)$ .
- (ii) What would be the corresponding power in the demodulator output  $Z(t)$  in the absence of noise?
- (iii) If  $n(t)$  is a white Gaussian process with  $S_n(f) = \frac{N_0}{2}$ , what is the noise power in the demodulator output for  $N_0 = 0.0001 \text{ mW/Hz}$ ?
- (iv) Find the SNR for this system at the demodulator output.

[20 marks]

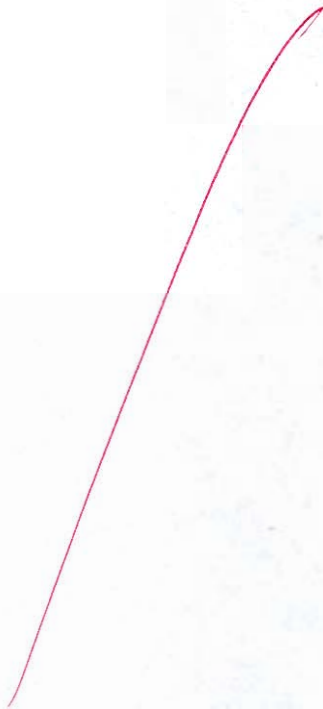

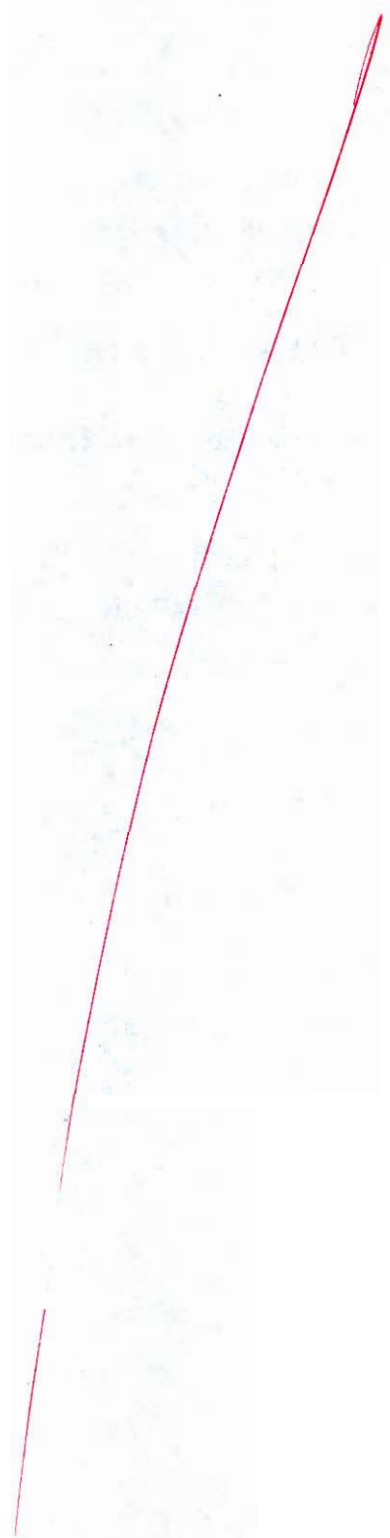

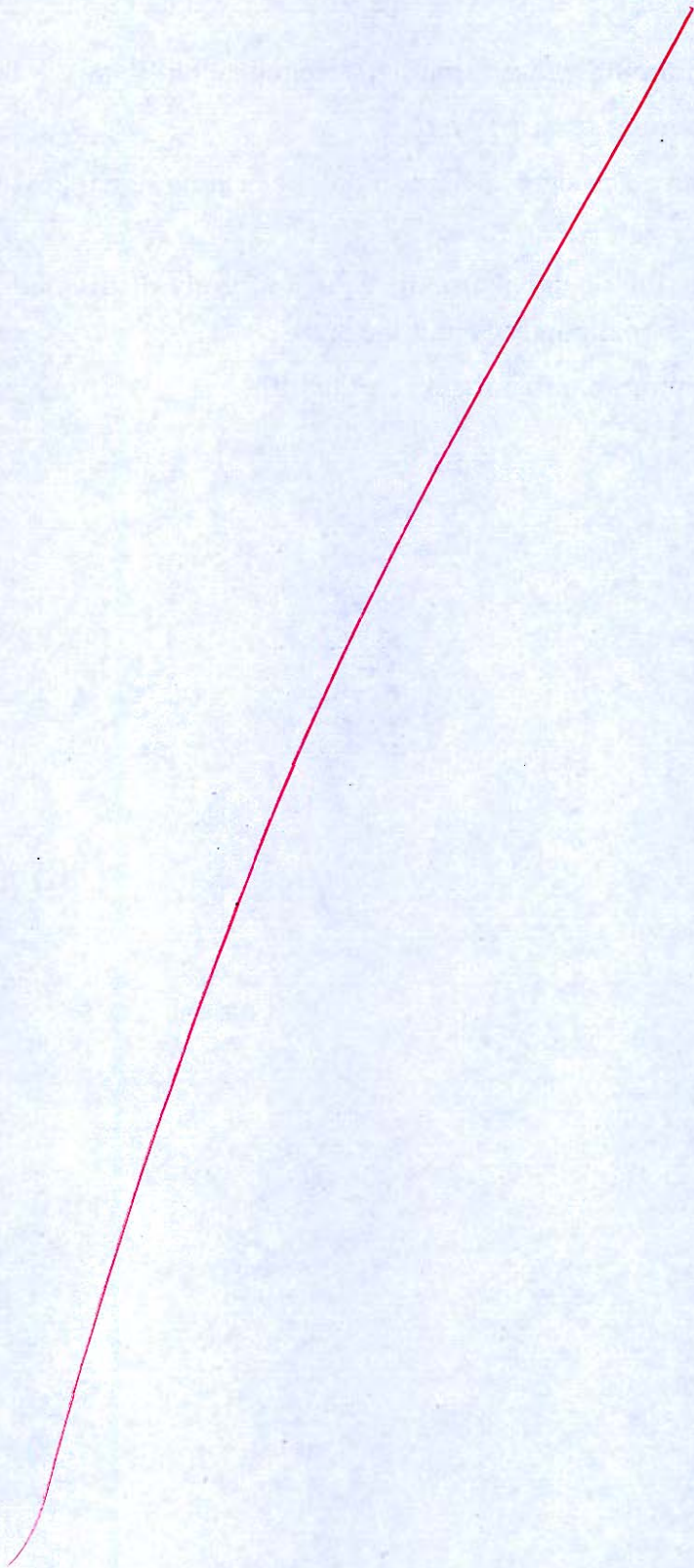

- Q.2 (b) In a single integration Delta Modulation system, the voice signal bandwidth is 3.4 kHz sampled at a rate of 64 kHz, similar to PCM. The maximum signal amplitude is normalized as  $A_{max} = 1$ .
- (i) Determine the minimum value of the step size  $\sigma$  to avoid slope overload.
  - (ii) Determine the granular noise power  $N_0$ .
  - (iii) Assuming that the voice signal is sinusoidal, determine signal power  $S_0$  and the SNR.
  - (iv) Assuming that the voice signal amplitude is uniformly distributed in the range  $(-1, 1)$ , determine signal power  $S_0$  and the SNR.
  - (v) Determine the minimum transmission bandwidth.

[20 marks]

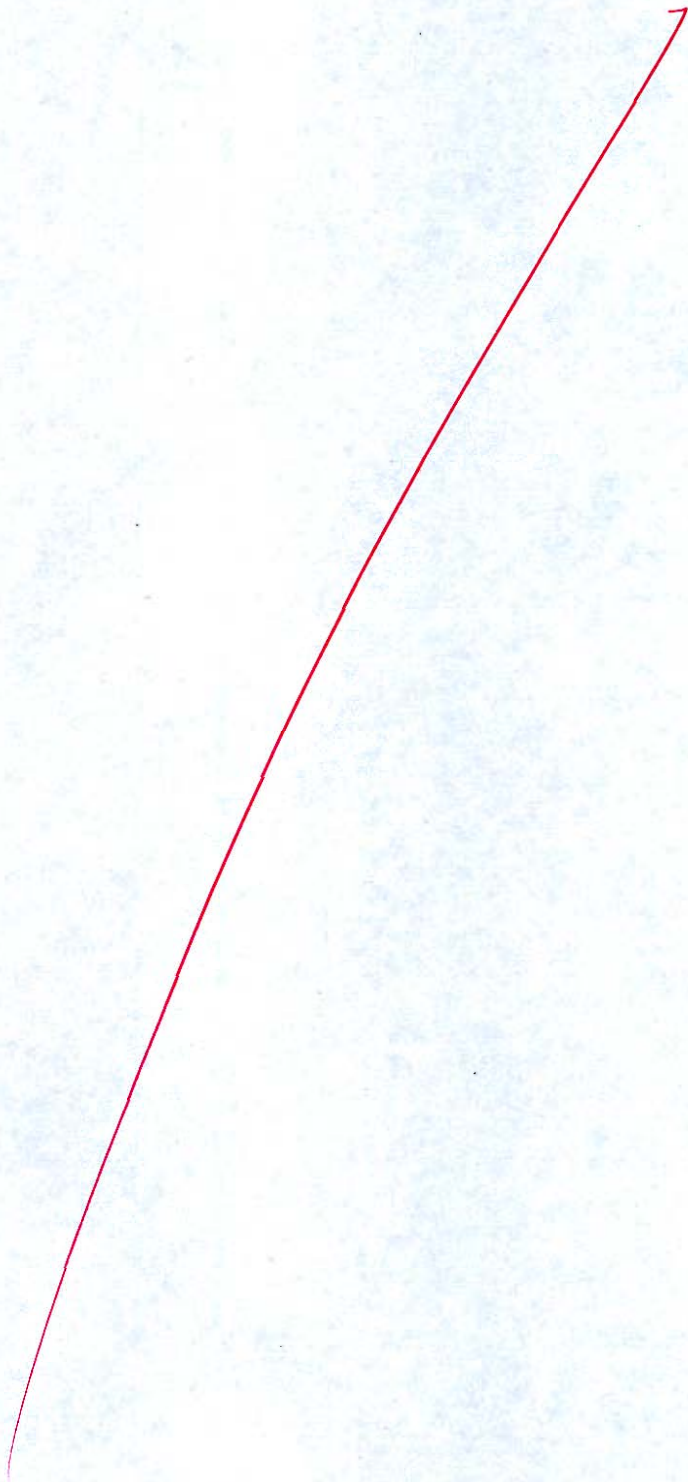

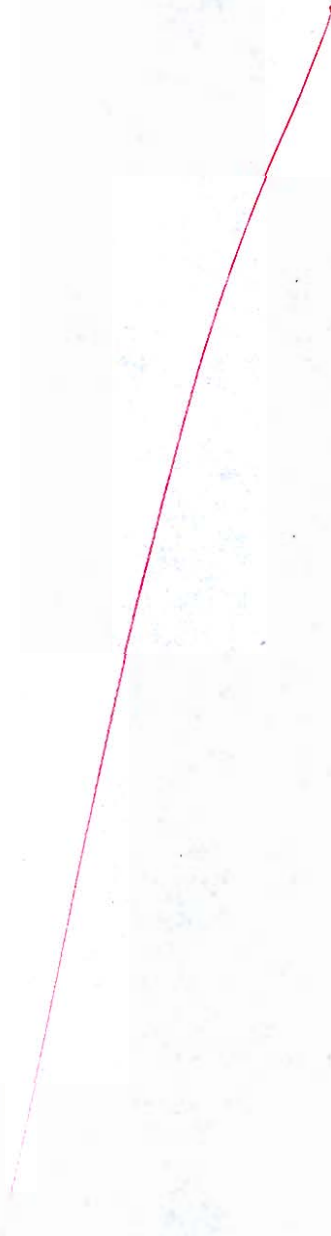

2 (c) A noise process has a power spectral density given by figure (a).

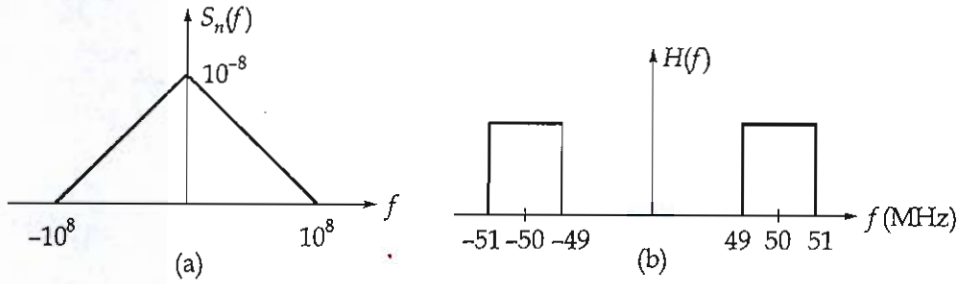

$$S_n(f) = 10^{-8} \left( 1 - \frac{|f|}{10^8} \right), \text{ for } |f| < 10^8 \text{ Hz}$$

$$= 0, |f| > 10^8 \text{ Hz}$$

The noise is passed through an ideal bandpass filter with  $H(f)$  as shown in figure (b) with a bandwidth of 2 MHz centered at 50 MHz.

- (i) Find the power content of the output noise.
- (ii) Write the output noise in terms of the in phase and quadrature components and find the power in each component.
- (iii) Find the power spectral density of these two components.
- (iv) Find the auto-correlation function of the in-phase component.

[20 marks]

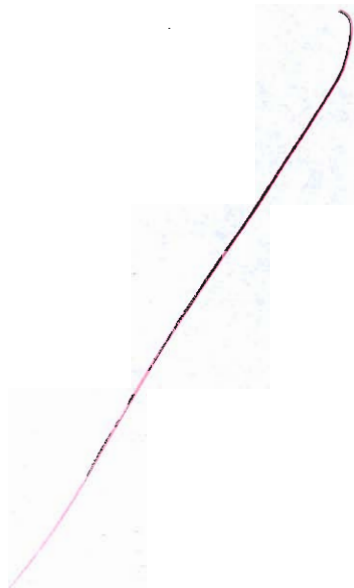

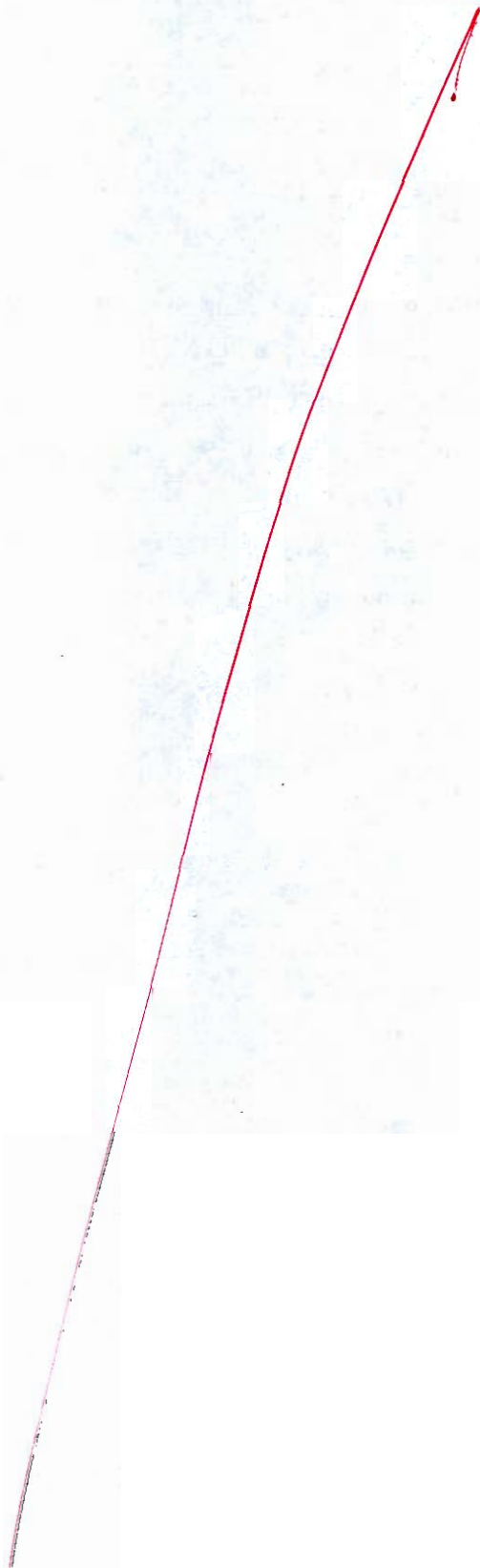

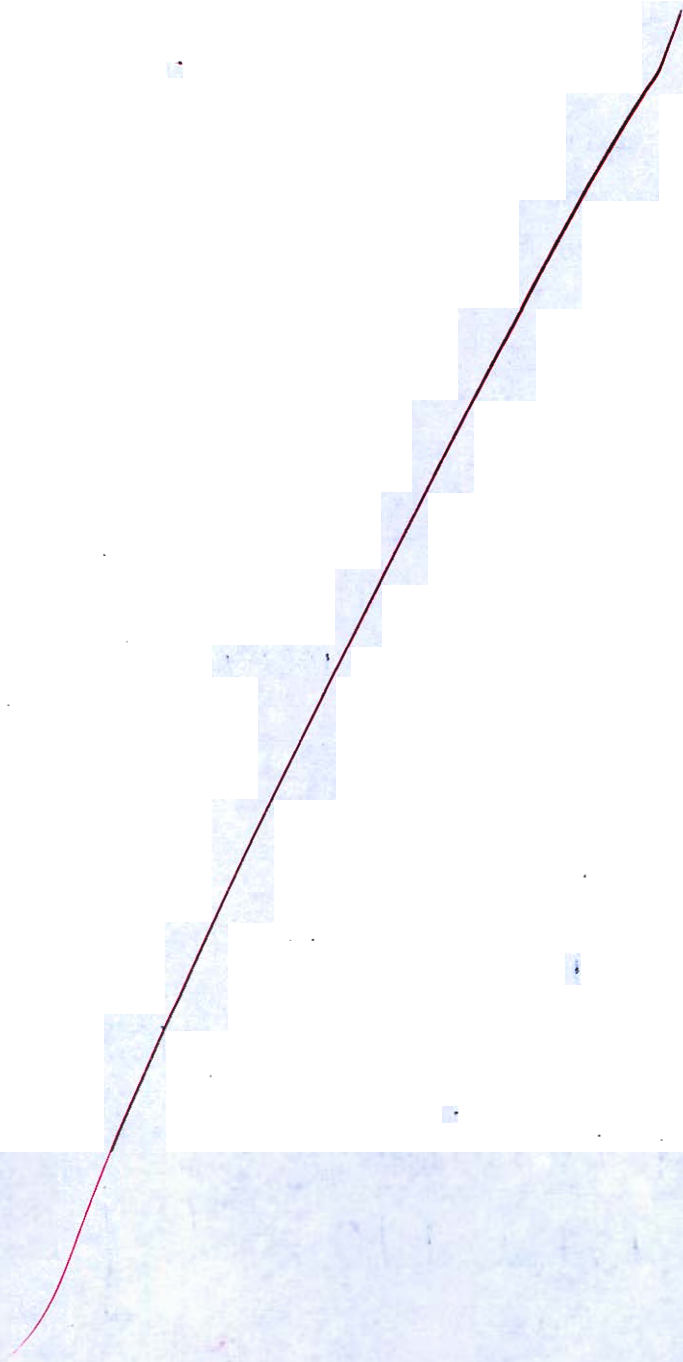

- Q.3 (a) (i) An angle modulated signal is given by the following expression  
 $u(t) = 5 \cos[2\pi f_c t + 40 \sin(500\pi t) + 20 \sin(1000\pi t) + 10 \sin(2000\pi t)]$
1. If  $u(t)$  is a PM signal,
    - (a) Determine the maximum phase deviation  $\Delta\phi_{\max}$ .
    - (b) If the phase deviation constant is  $k_p = 5$  radian per volt, determine the message signal  $m(t)$ .
  2. If  $u(t)$  is a FM signal,
    - (a) Determine the maximum frequency deviation,  $\Delta f_{\max}$ .
    - (b) If the frequency deviation constant is  $k_f = 10000\pi$  rad/sec per volt, determine the message signal  $m(t)$ .
- (ii) Show that the probability of error for a BPSK transmission system in which the

coherent receiver carrier has a phase error of  $\theta$  is given by  $P_e = Q \left[ \sqrt{\frac{2E_b \cos^2 \theta}{N_0}} \right]$

[12 + 8 marks]

Solw:

Q.3(a)(i) Given:

$$u(t) = 5 \cos[2\pi f_c t + 40 \sin(500\pi t) + 20 \sin(1000\pi t) + 10 \sin(2000\pi t)] \quad \text{---(1)}$$

1. (a)  $(\Delta\phi)_{\max}$  will be

$$\phi(t) = 2\pi f_c t + 40 \sin(500\pi t) + 20 \sin(1000\pi t) + 10 \sin(2000\pi t)$$

$$\therefore \Delta\phi = 40 \sin(500\pi t) + 20 \sin(1000\pi t) + 10 \sin(2000\pi t)$$

$$\therefore [\Delta\phi]_{\max} = 40 + 20 + 10 = 70$$

2. (b)  $k_p = 5 \frac{\text{rad}}{\text{volt}}$

The message signal  $m(t)$  is given by,

$$s_{pm}(t) = A_c \cos(2\pi f_c t + k_p m(t)) \quad \text{---(2)}$$

on comparing (1) & (2) we get  
 $k_f m(t) = 40 \sin(500\pi t) + 20 \sin(1000\pi t) + 10 \sin(2000\pi t)$

$$\therefore m(t) = 8 \sin(500\pi t) + 4 \sin(1000\pi t) + 2 \sin(2000\pi t)$$

Q. of  $v(t)$  is a FM signal.

(a) the maximum frequency deviation  $(\Delta f)_{\max}$  is

$$v(t) = A_c \cos(2\pi f_c t + 2\pi k_f \int_{-\infty}^t m(t) dt) \quad (3)$$

$\therefore$  from equation (1)

$$\Delta \omega(t) = 40 \sin(500\pi t) + 20 \sin(1000\pi t) + 10 \sin(2000\pi t)$$

$$\Delta \omega(t) = \frac{d\omega(t)}{dt} \Big|_{\max}$$

$$= 40 \times 500\pi + 20 \times 1000\pi + 10 \times 2000\pi$$

$$\therefore \Delta f_{\max} = \frac{\Delta \omega}{2\pi} = \frac{40 \times 500\pi}{2\pi} + \frac{20 \times 1000\pi}{2\pi} + \frac{10 \times 2000\pi}{2\pi}$$

$$\Delta f_{\max} = 30 \times 10^3 \text{ Hz}$$

(b)  $k_f = 10000\pi \frac{\text{rad}}{\text{sec Volt}}$  then  $m(t) = ?$

on comparing (1) and (3)

$$k_f \int_{-\infty}^t m(t) dt = 40 \sin(500\pi t) + 20 \sin(1000\pi t) + 10 \sin(2000\pi t)$$

Very Good

12

$\therefore$  on differentiating on both sides,  
 $\therefore K_p m(t) = 40 \times 500\pi \cos(500\pi t) +$   
 $20 \times 1000\pi \cos(1000\pi t) +$   
 $10 \times 2000\pi \cos(2000\pi t)$

$\therefore m(t) = 2 \cos(500\pi t) + 2 \cos(1000\pi t)$   
 $+ 2 \cos(2000\pi t)$

$\therefore m(t) = 2 [\cos(500\pi t) + \cos(1000\pi t) + \cos(2000\pi t)]$

Q.3 (a) (ii) Constellation diagram for BPSK:

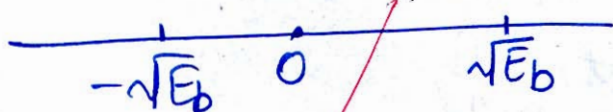

$\therefore P_e = Q\left(\sqrt{\frac{d_{\min}^2}{2N_0}}\right)$

$\therefore d_{\min}^2 = 2\sqrt{E_b}$

$\therefore P_e = Q\left(\sqrt{\frac{4E_b}{2N_0}}\right)$

$\therefore P_e = Q\left(\sqrt{\frac{2E_b}{N_0}}\right)$

Now, if coherent receiver carrier has a phase error of  $\theta$   $P_e$  given by

$P_e = Q\left(\sqrt{\frac{2E_b}{N_0} \cos^2 \theta}\right)$



- 2.3 (b) (i) Given a Binary Symmetric Channel (BSC) in below figure with  $P(x_1) = \alpha$ .
1. Show that the mutual information  $I(X; Y) = H(Y) + p \log_2 p + (1 - p) \log_2(1 - p)$
  2. Calculate  $I(X; Y)$  for  $\alpha = 0.5$  and  $p = 0.1$ .
  3. Repeat part (2) for  $\alpha = 0.5$  and  $p = 0.5$ .

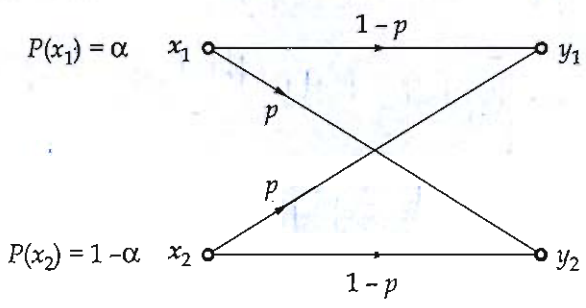

- (ii) Assuming that  $X$  is a Gaussian random variable with  $m = 0$  and  $\sigma = 1$ , find the probability density function of the random variable  $Y$  given by  $Y = aX + b$ .

[12 + 8 marks]

solu (3)

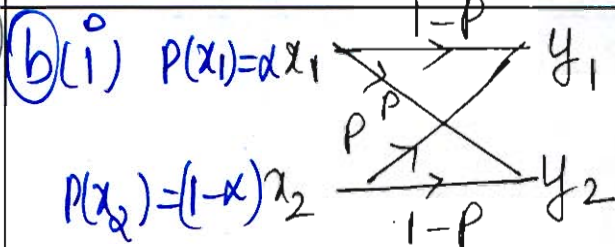

For a BSC :

$$P\left(\frac{Y}{X}\right) = \begin{matrix} x_1 & \begin{bmatrix} y_1 & y_2 \\ 1-P & P \\ P & 1-P \end{bmatrix} \\ x_2 & \end{matrix}$$

Joint probability,

$$\frac{P(X, Y)}{P(X)} = P\left(\frac{Y}{X}\right)$$

$$\therefore P(X, Y) = P\left(\frac{Y}{X}\right) \cdot P(X)$$

$$\therefore P(X, Y) = \begin{bmatrix} \alpha(1-P) & \alpha P \\ (1-\alpha)P & (1-\alpha)(1-P) \end{bmatrix}$$

The information is given by,

$$I(X; Y) = H(X) - H\left(\frac{Y}{X}\right) = H(Y) - H\left(\frac{Y}{X}\right)$$

where,  $H(Y) = -[p_{y1} \log_2 p_{y1} + p_{y2} \log_2 p_{y2}]$  — (1)

$$\therefore H(Y) = p_{y1} \left[ \log_2 \left[ \frac{1}{p_{y1}} \right] \right] + p_{y2} \log_2 \frac{1}{p_{y2}}$$

where,  $p_{y1} = \alpha(1-P) + (1-\alpha)P$

$$= \alpha - \alpha P + P - \alpha P$$

$$= \alpha + P - 2\alpha P \quad \text{--- (a)}$$

$$p_{y2} = \alpha P + (1-\alpha)(1-P)$$

$$= \alpha P + 1 - P - \alpha + \alpha P$$

$$= 1 - P - \alpha + 2\alpha P \quad \text{--- (b)}$$

and  $H\left(\frac{Y}{X}\right) = \sum_{j=1}^m P\left(\frac{Y_j}{X_j}\right) \log_2 P\left(\frac{Y_j}{X_j}\right)$

$\therefore H\left(\frac{Y}{X}\right) = (1-p) \log_2 (1-p) - p \log_2 p - p \log_2 p$   
 $\underline{(1-p) \log_2 (1-p)}$  2

$\therefore I(X; Y) = H(Y) - H\left(\frac{Y}{X}\right)$

from (1) and (2)

$\therefore I(X; Y) = H(Y) + p \log_2 p + (1-p) \log_2 (1-p)$

2.  $I(X; Y)$  for  $\alpha = 0.5$  and  $P = 0.1$

$H(Y) = P_{Y_1} \log_2 \frac{1}{P_{Y_1}} + P_{Y_2} \log_2 \frac{1}{P_{Y_2}}$

~~where~~ where, from (a) & (b)

$P_{Y_1} = \alpha(1-p) + (1-\alpha)p$   
 $P_{Y_1} = 0.5(1-0.1) + (1-0.5) \times 0.1 = 0.5$

$P_{Y_2} = \alpha p + (1-\alpha)(1-p)$   
 $= 0.5 \times 0.1 + (1-0.5)(1-0.1) = 0.5$

$\therefore H(Y) = -[0.5 \log_2 0.5 + 0.5 \log_2 0.5]$   
 $\therefore H(Y) = -2 \times 0.5 \log_2 0.5 = 1 \frac{\text{bits}}{\text{symbol}}$

$\therefore I(X; Y) = 1 + 0.1 \log_2 0.1 + (1-0.1) \log_2 (1-0.1)$

$I(X; Y) = 0.531$  bits

3.  $P_{Y_1} = \alpha(1-p) + (1-\alpha)p$   
 $P_{Y_1} = 0.5(1-0.5) + (1-0.5)(0.5) = 0.5$

$P_{Y_2} = \alpha p + (1-\alpha)(1-p) = (0.5)(0.5) + (1-0.5)(1-0.5)$   
 $= 0.5$

Q.3.  $\alpha = 0.5$  and  $P = 0.5$

$$H(Y) = P_{Y_1} \log_2 \frac{1}{P_{Y_1}} + P_{Y_2} \log_2 \frac{1}{P_{Y_2}}$$

$$\therefore H(Y) = -2 \times 0.5 \log_2 0.5$$

$$H(Y) = 1 \frac{\text{bits}}{\text{symbol}}$$

$$\therefore I(X; Y) = 1 + 0.5 \log_2 0.5 + (1-0.5) \log_2 (1-0.5)$$

$$\therefore I(X; Y) = 0$$

(8) ans ✓

Q.3 (b) (ii) mean,  $m = 0$

SD,  $\sigma = 1$

$$f_x(x) = \frac{1}{\sqrt{2\pi\sigma^2}} e^{-\frac{(x-\mu)^2}{2\sigma^2}}$$

for  $m = 0$   $\sigma = 1$

$$\therefore f_x(x) = \frac{1}{\sqrt{2\pi}} e^{-\frac{x^2}{2}}$$

now,  $y = ax + b$

$$\therefore f_y(y) = \left| \frac{dx}{dy} \right| f_x(x)$$

$$\therefore \frac{dy}{dx} = a$$

$$\therefore f_y(y) = \frac{1}{a} f_x(x)$$

$$\therefore f_y(y) = \frac{1}{a\sqrt{2\pi}} e^{-\frac{x^2}{2}}$$

incomplete  
soln

(5)

3 (c) (i) A DPCM system uses a linear predictor with a single tap. The normalized autocorrelation function of the input signal for a lag of one sampling interval is 0.75. The predictor is designed to minimize the prediction error variance. Determine the processing gain attained by the use of this predictor.

(ii) Show that the signal  $V(t) = \sum_{i=1}^N [\cos \omega_c t \cdot \cos(\omega_i t + \theta_i) - \sin \omega_c t \cdot \sin(\omega_i t + \theta_i)]$  is an SSB

signal. It is USB or LSB? Write an expression for the missing sideband. Obtain an expression for the total DSB-SC signal.

[12 + 8 marks]

Sol: (i)  $V(t) = \sum_{i=1}^N \cos \omega_c t \cos(\omega_i t + \theta_i) - \sin \omega_c t \sin(\omega_i t + \theta_i)$

(ii)  $\cos a \cos b - \sin a \sin b = \cos(a+b)$

$\therefore V(t) = \sum_{i=1}^N \cos(\omega_c t + \omega_i t + \theta_i)$

$\therefore V(t) = \cos(\omega_c t + \omega_1 t + \theta_1) + \cos(\omega_c t + \omega_1 t + \theta_2) + \dots + \cos(\omega_c t + \omega_n t + \theta_n)$

Now, it is clear from above expressions that contains the sidebands at different frequencies.

The above signal given is a USB.

incomplete soln

4



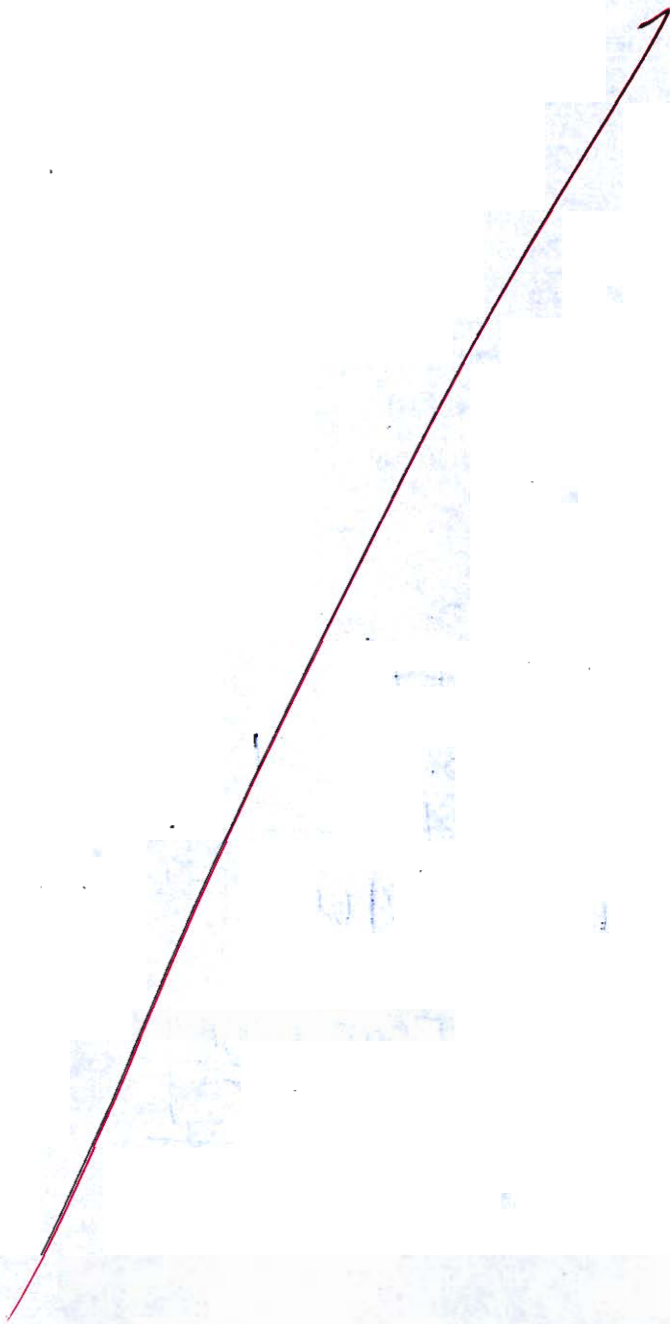

- Q.4 (a) (i) Consider the (5, 1) repeating code, with the generator matrix as  
 $G = [1 \ 1 \ 1 \ 1 \ 1 \ ; \ 1]$   
 Evaluate the syndrome  $S$  for the following error pattern.
- All five possible single error patterns.
  - All 10 possible double error patterns.
- (ii) The auto-correlation function of an ergodic random process  $x(t)$  is given by the expression:

$$R_X(\tau) = \frac{25\tau^2 + 36}{6.25\tau^2 + 4}$$

- Find the mean value ( $\mu_x$ ) and the mean square value ( $E[X^2(t)]$ ) of the process.
- Determine the variance ( $\sigma_x^2$ ) of the process  $X(t)$ .
- Comment on the physical significance of  $R_X(0)$  and  $R_X(\infty)$  for a stationary random process.

[12 + 8 marks]

solw: Q.4(a)(ii)

$$R_X(\tau) = \frac{25\tau^2 + 36}{6.25\tau^2 + 4}$$

$$1. \quad E[X^2(t)] = R_X(0) = \frac{36}{4} = 9 \quad \text{--- (1)}$$

Since, it's a ergodic random process.

therefore,

$$E[\mu_x^2] = R_X(\infty) = \frac{\tau^2 \left[ 25 + \frac{36}{\tau^2} \right]}{\tau^2 \left[ 6.25 + \frac{4}{\tau^2} \right]}$$

$$E[\mu_x^2] = 4$$

$\therefore$  Power of mean = 4

$$\mu_x^2 = 4$$

$$\mu_x = \pm \sqrt{4}$$

$$\therefore \mu_x = 2 \quad \text{--- (2)}$$

$$2. \sigma_x^2 = E[x^2] - \{E[x]\}^2$$

$$\therefore \sigma_x^2 = 9 - (2)^2$$

from (1) &  
(2)

$$\sigma_x^2 = 5$$

3. The  $R_x(0)$  represents the total power present in the signal. whereas,  $R_x(\infty)$  represents the total mean power or DC power present in the signal.

(8) Good

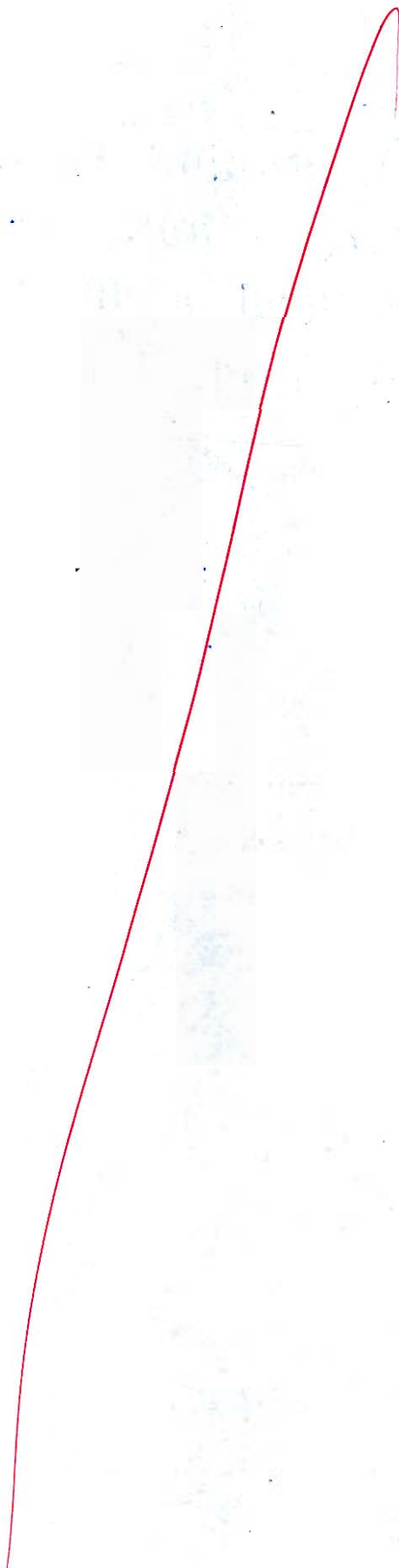

Q.4 (b) (i) A pair of noise processes  $n_1(t)$  and  $n_2(t)$  are related by  $n_2(t) = n_1(t) \cos(2\pi f_c t + \theta) - n_1(t) \sin(2\pi f_c t + \theta)$  Where  $f_c$  is a constant and  $\theta$  is a random variable, whose probability density function is given by

$$f_\theta(\theta) = \begin{cases} \frac{1}{2\pi}, & 0 \leq \theta \leq 2\pi \\ 0, & \text{otherwise} \end{cases}$$

The noise process  $n_1(t)$  is stationary and its power spectral density is as shown in figure. Find and plot the corresponding power spectral density of  $n_2(t)$ .

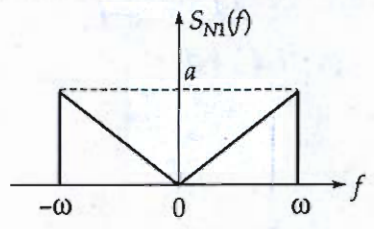

(ii) For the following communication system:

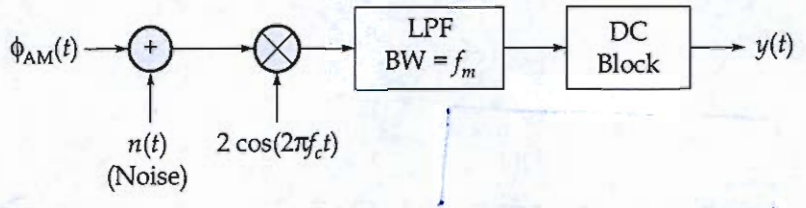

where,  $\phi_{AM}(t) = A_c [1 + \cos(2\pi f_m t)] \cos(2\pi f_c t)$   
 $n(t) = n_c(t) \cos(2\pi f_c t) - n_s(t) \sin(2\pi f_c t)$

Noise power,  $= \overline{n_c^2(t)} = \overline{n_s^2(t)} = 2N_0 f_m$

1. Analyze the system and write an equation for the output signal  $y(t)$ .
2. Write the equation for the signal-to-noise ratio at the output.
3. Let  $A_c = 10$  V,  $f_m = 10$  kHz and  $N_0 = 10$   $\mu$ W/Hz. Find the signal-to-noise ratio.

[12 + 8 marks]

sol

Q.4(b)(i) :

7

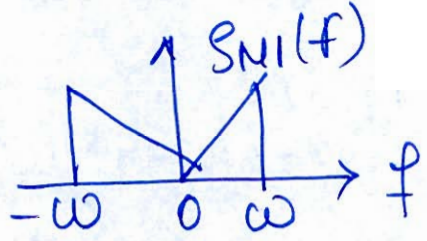

$n_2(t) = n_1(t) \cos(2\pi f_c t + \theta) - n_1(t) \sin(2\pi f_c t + \theta)$   
 $n_2(t)$  is written in inphase and quadrature phase component of  $n_1(t)$ .

$$S_{n2}(f) = \frac{1}{2} S_{n1}(f - f_c) + S_{n1}(f + f_c)$$

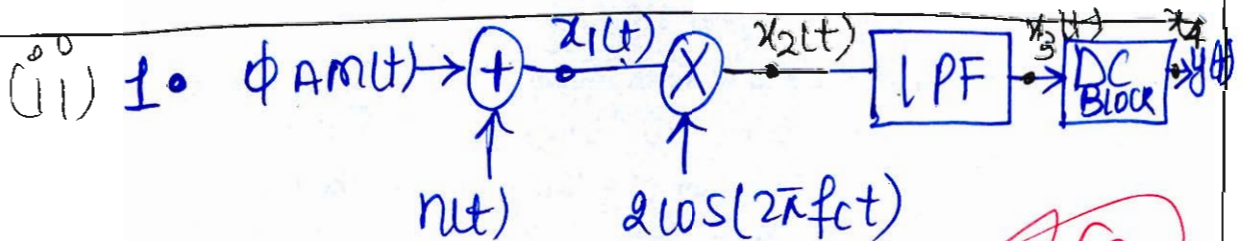
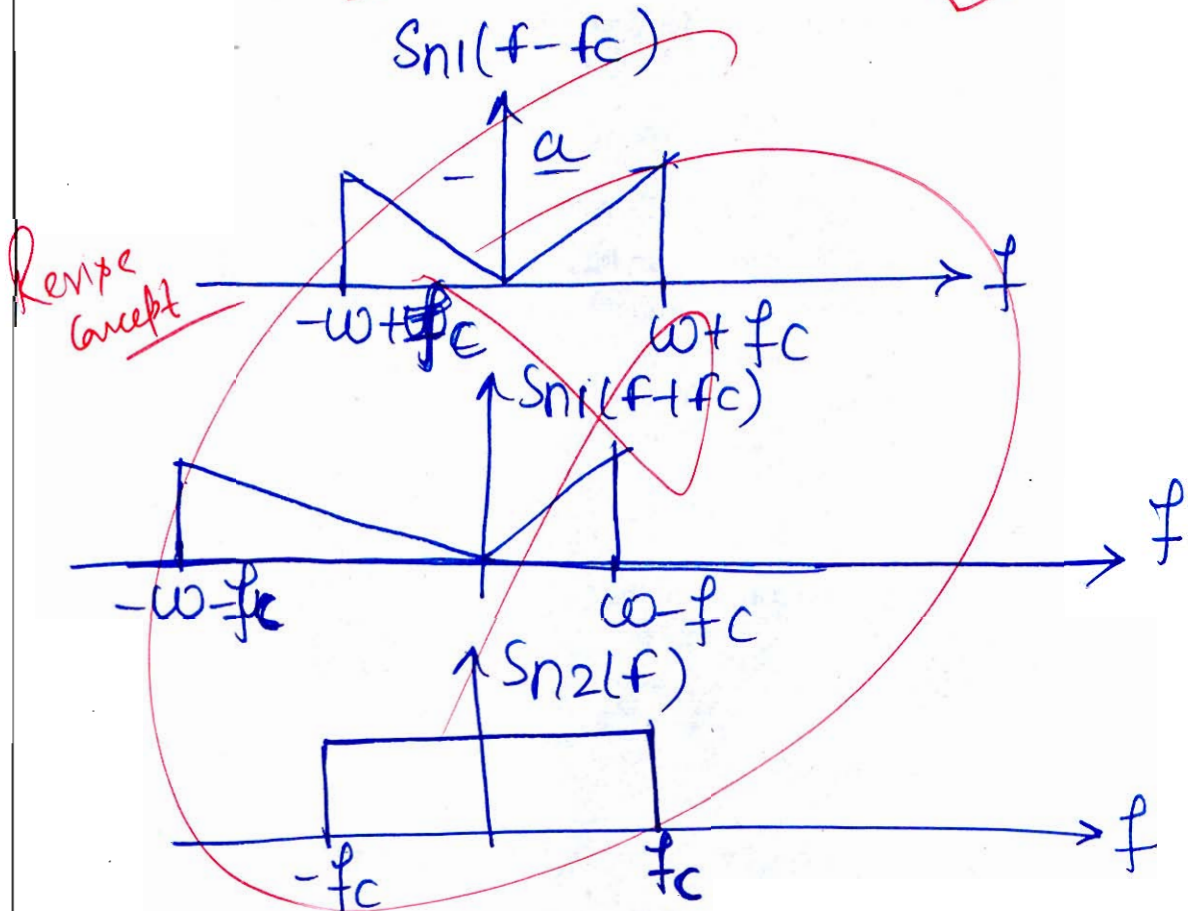

$$\therefore x_1(t) = \phi A m(t) + n(t)$$

$$x_1(t) = \{ A_c [1 + \cos(2\pi f_m t)] \cos 2\pi f_c t \} + [ n_c(t) \cos(2\pi f_c t) - n_s(t) \sin 2\pi f_c t ]$$

$$x_2(t) = x_1(t) \cdot 2 \cos(2\pi f_c t)$$

$$\therefore x_2(t) = 2A_c [1 + \cos 2\pi f_m t] \cos 2\pi f_c t \cdot \cos 2\pi f_c t + 2n_c(t) \cos^2(2\pi f_c t) - 2n_s(t) \cos 2\pi f_c t \sin 2\pi f_c t$$

$$x_2(t) = 2A_c [1 + \cos 2\pi f_m t] \left[ \frac{1 + \cos 4\pi f_c t}{2} \right] + 2n_c(t) \left[ \frac{1 + \cos 4\pi f_c t}{2} \right] - n_s(t) \left[ \sin(2\pi f_c t + 2\pi f_c t) + \sin(2\pi f_c t - 2\pi f_c t) \right]$$

After passing through LPF,

$$x_2(t) = A_c (1 + \cos 2\pi f_m t) + n_c(t)$$

After passing through DC Blocker

$$y(t) = A_c (1 + \cos 2\pi f_m t)$$

2. signal to noise ratio is:

$$\text{Signal Power} = \frac{A_c^2}{2} + A_c^2$$

$$\text{Noise Power} = 2N_0 f_m$$

$$\therefore \frac{S}{N} = \frac{A_c^2/2 + A_c^2}{2N_0 f_m} = \frac{3}{4} \frac{A_c^2}{N_0 f_m}$$

3. let  $A_c = 10V$ ,  $f_m = 10KHz$ ,  $N_0 = 10 \mu W / Hz$

$$\frac{S}{N} = \frac{3}{4} \frac{A_c^2}{N_0 f_m}$$

$$\therefore \frac{S}{N} = \frac{3}{4} \times \frac{(10)^2}{10 \times 10^{-6} \times 10 \times 10^3}$$

$$\frac{S}{N} = 750$$

$$\frac{S}{N} = 28.75 \text{ dB}$$

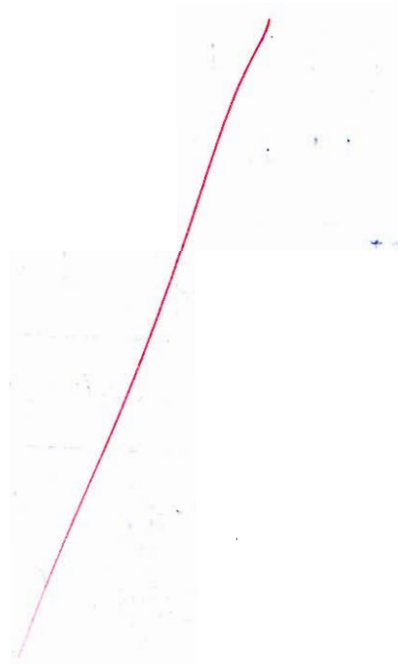

Q.4 (c) (i) An FM signal  $x_c(t) = A_c \cos \left[ \omega_c t + \int_{-\infty}^t m(t) dt \right]$  is applied to a high-pass RC filter,

where  $RC \ll \frac{1}{\omega}$  with  $\omega$  representing the FM signal frequency band. Show if an envelope detector after the filter can demodulate the FM signal.

(ii) Consider a chain of  $(n - 1)$  regenerative repeaters, with a total of  $n$  sequential decisions made on a binary PCM wave, including the final decision made at the receiver. Assume that any binary symbol transmitted through the system has an independent probability  $P_1$  of being inverted by any repeater. Let  $P_n$  represent the probability that a binary symbol is in error after transmission through the complete system.

1. Show that  $P_n = \frac{1}{2} [1 - (1 - 2P_1)^n]$ .

2. If  $P_1$  is very small and  $n$  is not too large, what is value of  $P_n$ ?

[12 + 8 marks]

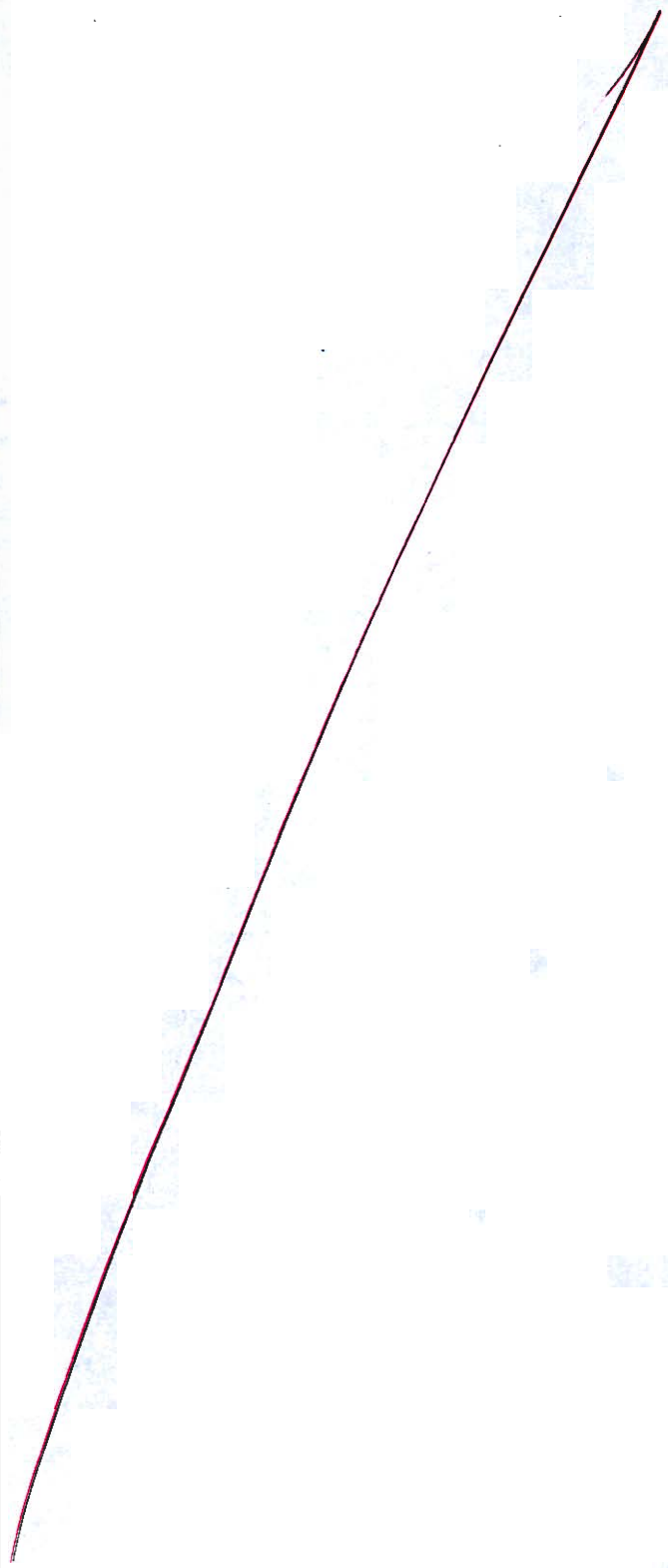



**Section B : Digital Circuit-1 + Microprocessors and Microcontroller  
Network Theory-2 + Signals and Systems-2**

5 (a) In the following base number systems, solve the equations for the value of 'X'.

(i)  $(70)_8 + (122)_6 = (211)_x$

(ii)  $(131)_{12} = (X)_8 + (78)_9$

[6 + 6 marks]

Sol: Q.5(a)(i)

$$(70)_8 + (122)_6 = (211)_x$$

$$7 \times 8^1 + 0 \times 8^0 + 1 \times 6^2 + 2 \times 6^1 + 2 \times 6^0 = 2 \times x^2 + x^1 + 1 \times x^0$$

$$\therefore 106 = 2x^2 + x + 1$$

$$2x^2 + x - 105 = 0$$

on solving

$$\boxed{x = 7}$$

Q.5. (a) (ii)  $(181)_{12} = (X)_8 + (78)_9$

$$\therefore 1 \times 12^2 + 3 \times 12^1 + 1 \times 12^0 = X \cdot 8^0 + 7 \times 9^1 + 8 \times 9^0$$

$$181 = X + 71$$

$$\therefore X = 181 - 71$$

$$X = 110$$

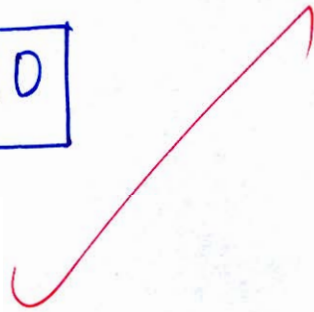

(12)

Ans ✓

5 (b) A parallel RLC circuit has the following values:  
 $R = 8 \text{ k}\Omega$ ,  $L = 0.2 \text{ mH}$ ,  $C = 8 \text{ }\mu\text{F}$  and  $V = 10 \sin \omega t (\text{V})$ .

Calculate:

- (i) Resonant frequency,  $\omega_0$ .
- (ii) 3 dB frequencies,  $\omega_1$  and  $\omega_2$ .
- (iii) Q and BW.
- (iv) Power dissipated at  $\omega_0$ ,  $\omega_1$  and  $\omega_2$ .

$$V_m = 10$$

$$V_{rms} = \frac{V_m}{\sqrt{2}} = \frac{10}{\sqrt{2}}$$

[12 marks]

(i)  $\omega_0 = \frac{1}{\sqrt{LC}}$

The resonant frequency is given by

$$\omega_0 = \frac{1}{\sqrt{0.2 \times 10^{-3} \times 8 \times 10^{-6}}}$$

$$\omega_0 = 25 \times 10^3 \frac{\text{rad}}{\text{sec}}$$

(ii) 3 dB frequencies,  $\omega_1$  and  $\omega_2$ :

$$\omega_1 = + \frac{BW}{2} + \sqrt{\left(\frac{BW}{2}\right)^2 + \frac{1}{LC}}$$

where,  $BW = \frac{R}{L}$

$$\omega_1 = \frac{R}{2L} + \sqrt{\left(\frac{R}{2L}\right)^2 + \frac{1}{LC}}$$

$$\omega_1 = \frac{8 \times 10^3}{2 \times 0.2 \times 10^{-3}} + \sqrt{\left(\frac{8 \times 10^3}{2 \times 0.2 \times 10^{-3}}\right)^2 + \frac{1}{0.2 \times 10^{-3} \times 8 \times 10^{-6}}}$$

$$\omega_1 = 400000 \pm 62 \frac{\text{rad}}{\text{sec}}$$

$$\omega_2 = 15.624 \frac{\text{rad}}{\text{sec}}$$

$$(ii) Q = R \sqrt{\frac{C}{L}}$$

$$Q = 8 \times 10^3 \times \left( \sqrt{\frac{8 \times 10^{-6}}{0.2 \times 10^{-3}}} \right)$$

$$Q = 1600$$

$$BW = \frac{\omega_0}{Q} = \frac{25 \times 10^3}{1600}$$

$$BW = 15.625 \frac{\text{rad}}{\text{sec}}$$

(iii) 3 dB frequencies,  $\omega_1$  and  $\omega_2$

$$\omega_1 = \pm \frac{BW}{2} \pm \sqrt{\left(\frac{BW}{2}\right)^2 + \frac{1}{LC}}$$

$$\therefore \omega_1 = \frac{15.625}{2} + \sqrt{\left(\frac{15.625}{2}\right)^2 + \left(\frac{1}{0.2 \times 10^{-3} \times 8 \times 10^{-6}}\right)}$$

$$\therefore \omega_1 = 25007.81 \frac{\text{rad}}{\text{sec}}$$

$$\omega_2 = 24992.18 \frac{\text{rad}}{\text{sec}}$$

$$\left. \begin{aligned} \omega_2 &= \omega_0 + \frac{BW}{2} \\ &= 25 \times 10^3 + \frac{15.625}{2} \end{aligned} \right\}$$

(iv) Power Dissipated at  $\omega_0$

$$P_{\omega_0} = \frac{V_{\text{rms}}^2}{R} = \frac{\left(\frac{10}{\sqrt{2}}\right)^2}{8} \text{ mW}$$

$$P_{\omega_0} = 6.25 \text{ mW}$$

$$\text{Power at } \omega_1, \omega_2 = \frac{P_{\omega_0}}{2} = \frac{6.25}{2} = 3.125 \text{ mW}$$

(c) The coefficients of a 7-point FIR filter are listed below. Draw a realization diagram for the filter such that a minimum number of multiplications is required for each output computation.

$$h(0) = -0.3$$

$$h(1) = 0.4$$

$$h(2) = 0.2$$

$$h(3) = 0.5$$

$$h(4) = 0.2$$

$$h(5) = 0.4$$

$$h(6) = -0.3$$

Also find out the order of the filter and the type of the FIR filter structure.

[12 marks]

-u

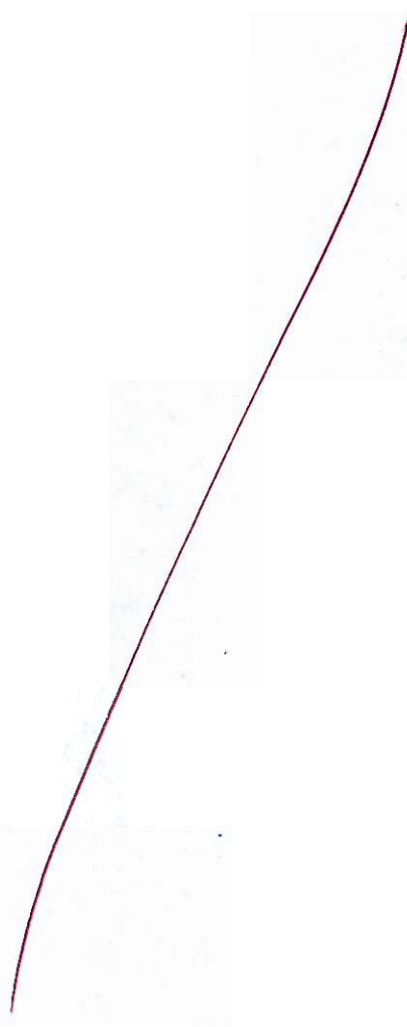

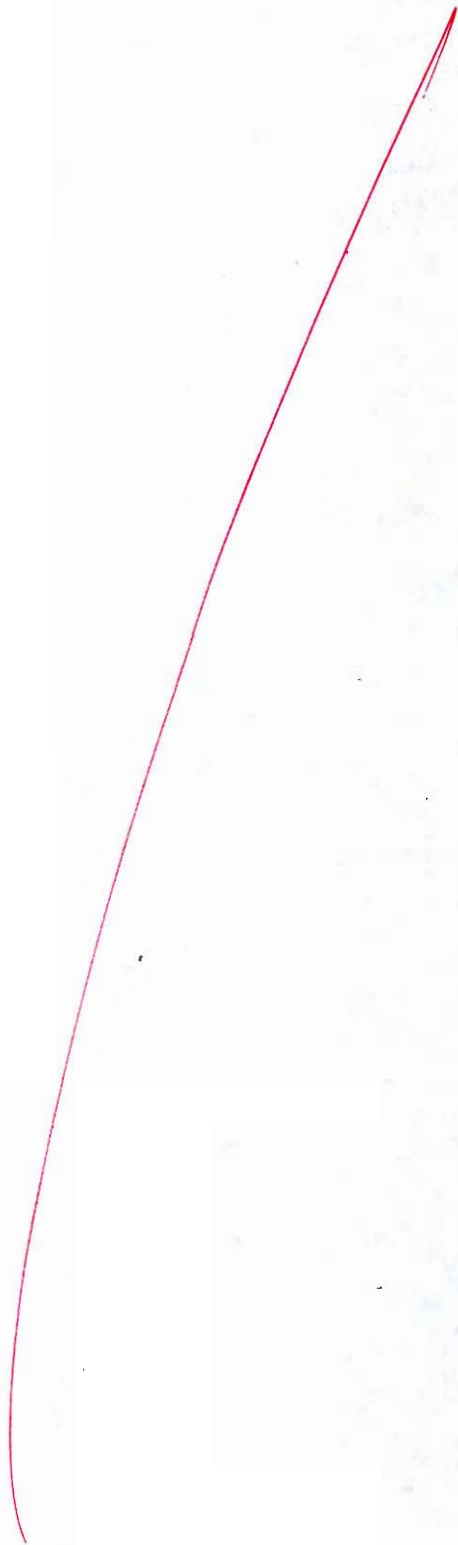

- 5 (d) Write a program for an 8085 microprocessor to calculate the sum of series of numbers. The length of series is stored in the memory location 1100H and the sequence is stored starting from location 2100H. Assume the sum to be 8-bit number without any carry and store the result in location 3200H.

[12 marks]

QW

~~12/20~~

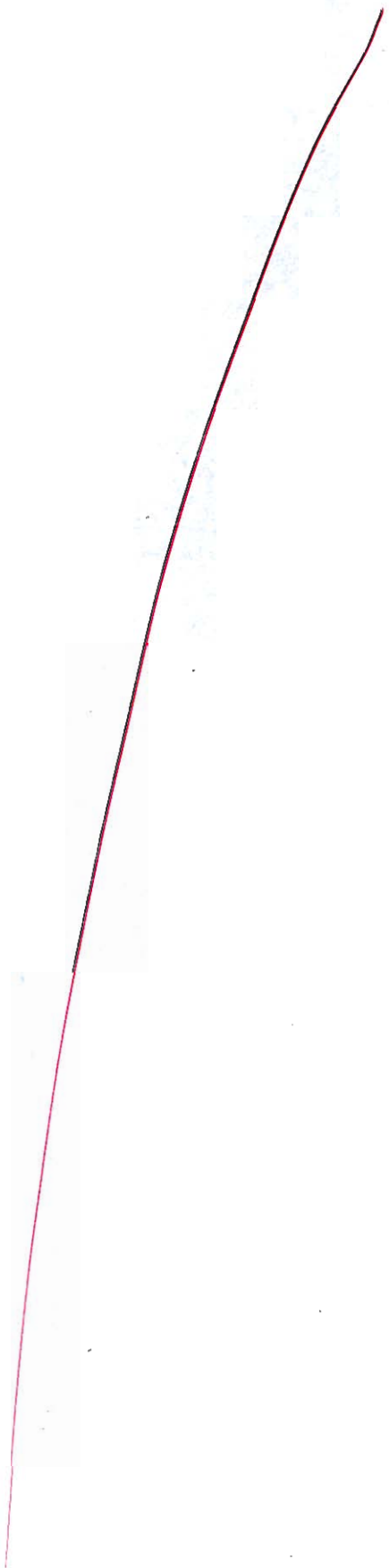

5 (e) (i) Define the following terms:

1. Setup time.
2. Hold time.

(ii) Convert the following number from base 9 to base 11,  $(18.6)_9 = (?)_{11}$

[6 + 6 marks]

u (i) 1. Setup time :

3 the setup time is the time required by the clock so that when input is arrived, systems starts processing.

2. Hold time :-

the time for which clock hold up so that there is no delay between clock and input is called Hold time.

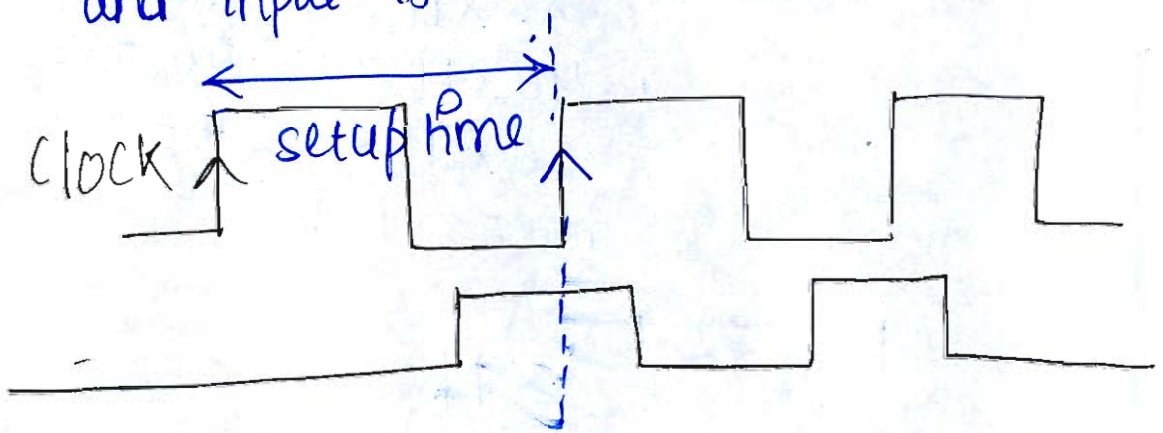

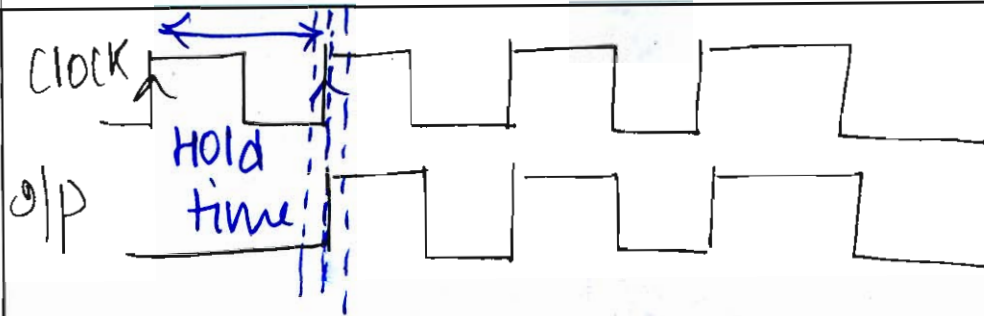

Q.5. (e) (ii) Base 9 to Base 11:

$$(18.6)_9 = (?)_{11}$$

Step 1: convert the base 9 number in decimal number.

$$\therefore 1 \times 9^1 + 8 \times 9^0 + 6 \times 9^{-1} = 17.66$$

Step 2: - Now convert 17 and 0.66 in base 11 as.

11	17	
	1	6

$$\therefore (17)_{10} \leftrightarrow (16)_{11}$$

and

$$0.66 \Rightarrow 0.66 \times 11 = 7.26 = 7$$

$$0.26 \times 11 = 2.86 = 2$$

$$0.86 \times 11 = 9.46 = 9$$

$$0.46 \times 11 = 5.06 = 5$$

$$0.06 \times 11 = 0.66 = 0$$

$\therefore$  The number in base 11 is

$$(16.7295)_{11}$$

(a) Consider the sequential circuit shown below:

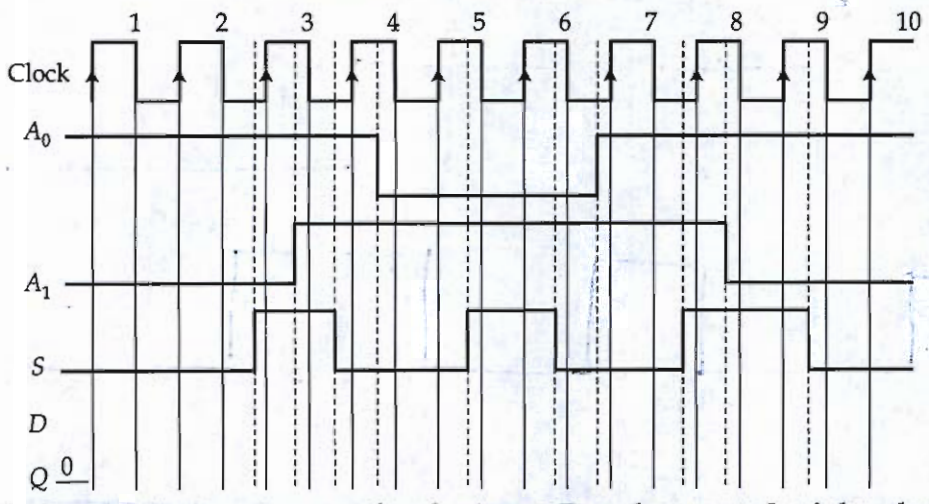
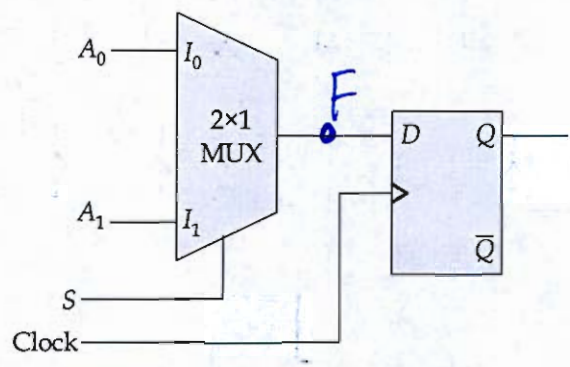

Draw the timing diagram for the input  $D$  and output  $Q$  of the above MUX operated D-flip-flop.

[20 marks]

u:

$$F = \bar{S}I_0 + S \cdot I_1$$

$$F = \bar{S} \cdot A_0 + S \cdot A_1$$

$$D = F = \bar{S}A_0 + S \cdot A_1$$

$$D = Q$$

20  
 ✓  
 ✓  
 ✓

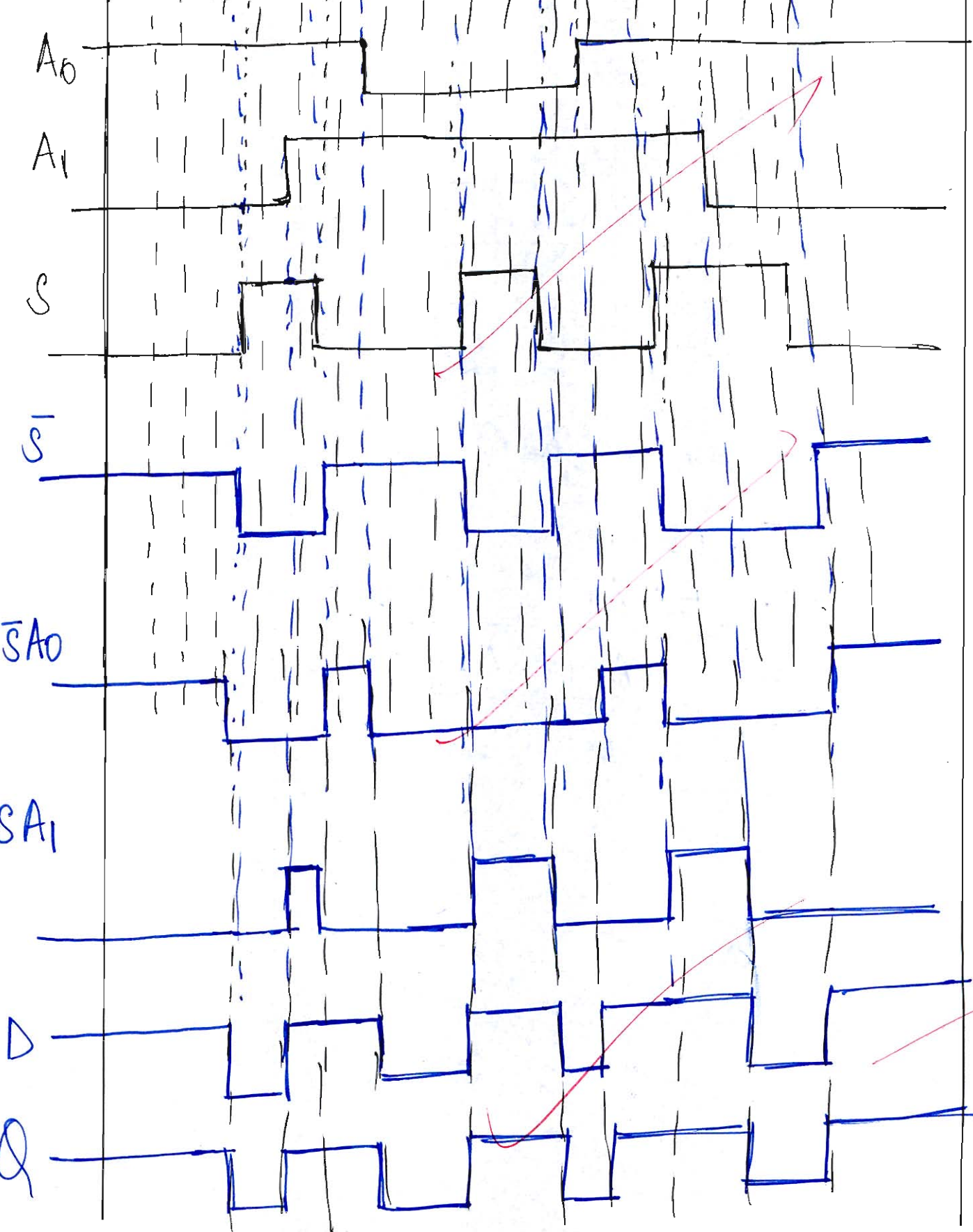
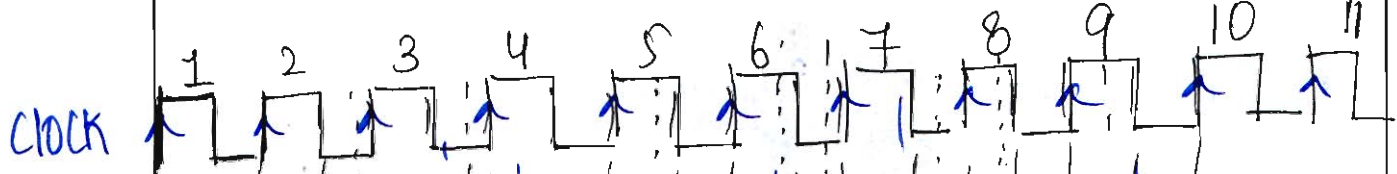
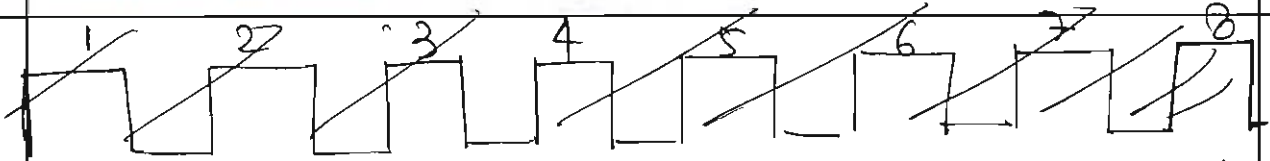

5 (b) Find the z and y parameter for the networks shown in figure below:

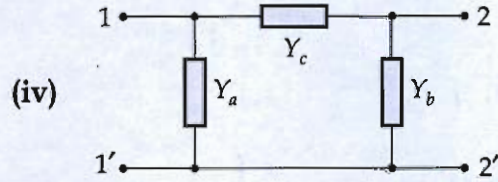
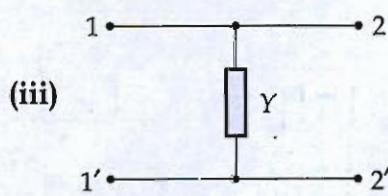
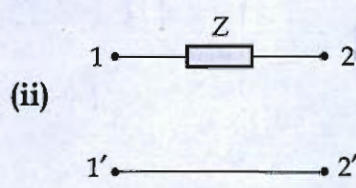
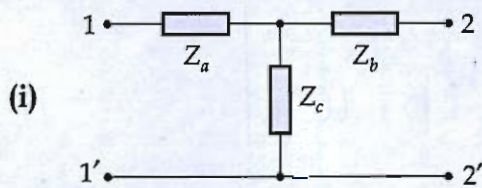

[20 marks]

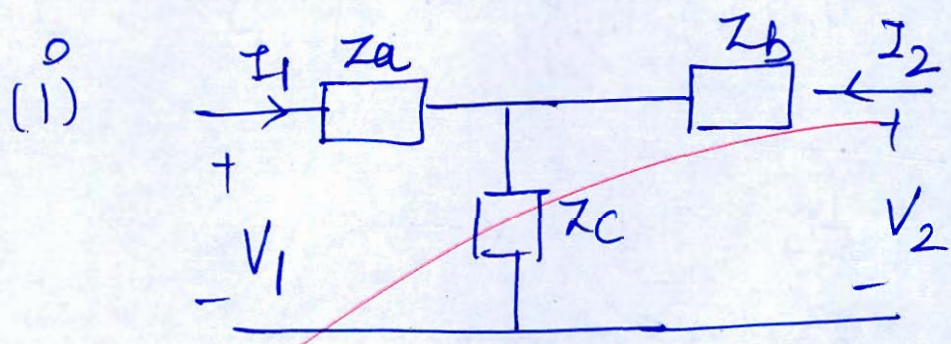

$$V_1 = (Z_a + Z_c) I_1 + Z_c I_2$$

$$V_2 = Z_c I_1 + (Z_b + Z_c) I_2$$

$$[Z] = \begin{bmatrix} (Z_a + Z_c) & Z_c \\ Z_c & Z_b + Z_c \end{bmatrix}$$

$$[Y] = [Z]^{-1}$$

$$[Y] = \frac{1}{(Z_a + Z_c)(Z_b + Z_c) - Z_c^2} \begin{bmatrix} Z_b + Z_c & -Z_c \\ -Z_c & Z_a + Z_c \end{bmatrix}$$

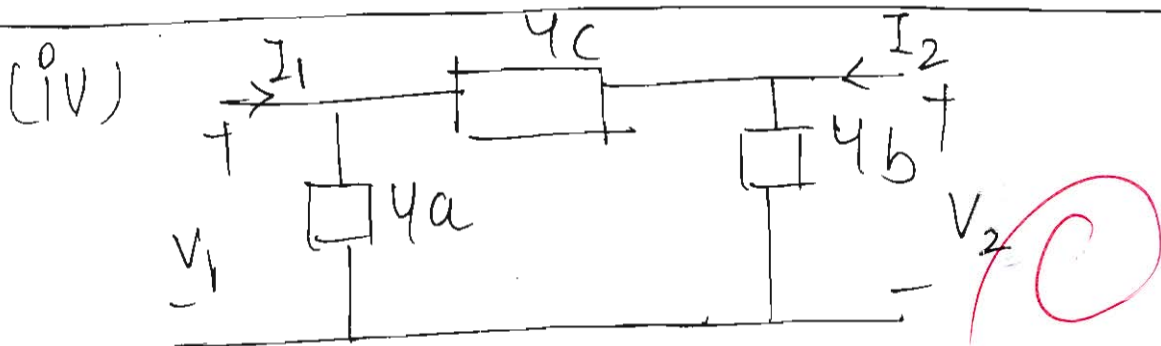

$$\therefore [Y] = \begin{bmatrix} Y_a + Y_c & -Y_b \\ -Y_b & Y_b + Y_c \end{bmatrix}$$

$$[Z] = [Y]^{-1}$$

$$[Z] = \frac{1}{(Y_a + Y_c)(Y_b + Y_c) - Y_b^2} \begin{bmatrix} Y_b + Y_c & Y_b \\ Y_b & Y_a + Y_c \end{bmatrix}$$

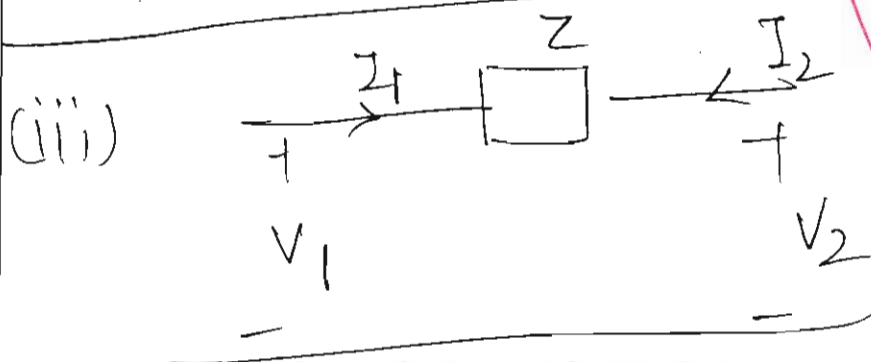

$$V_1 - I_1 Z - V_2 = 0$$

$$V_1 = I_1 Z + V_2$$

$$V_2 - I_2 Z - V_1 = 0$$

$$V_1 = I_1 Z + V_2 \quad \text{--- (1)}$$

$$V_2 = I_2 Z + V_1 \quad \text{--- (2)}$$

from (2) and (1)

$$V_1 = I_1 Z + I_2 Z + V_1$$

$$\therefore I_1 Z = -I_2 Z$$

$$\therefore \boxed{I_1 = -I_2}$$

$$V_1 = Z_{11} I_1 + Z_{12} I_2$$

$$V_2 = Z_{21} I_1 + Z_{22} I_2$$

Z parameters does not exist.

(ii)

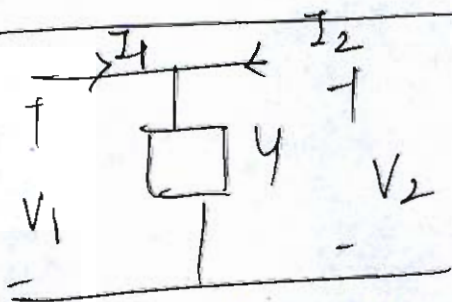

$$V_1 = V_2 \quad \text{and} \quad V_1 = \frac{1}{4} (I_1 + I_2)$$

$$V_1 = \frac{(I_1 + I_2)}{4}$$

$$\therefore \boxed{4V_1 = I_1 + I_2}$$

4 parameters does not exist.

$$Z = ?$$

- Q.6 (c) (i) Explain the various addressing modes in 8086 microprocessor.  
 (ii) Consider the following subroutine program of an 8085 microprocessor, which is operating with a clock frequency of 2 MHz:

```

MVI B, DATA_8 bit
LOOP: DCR B
      JNZ LOOP
      RET
  
```

Let "N" is the decimal equivalent of the DATA\_8 bit stored in B register. By analyzing the above program, derive an expression for the overall time delay produced by the subroutine. Using the result obtained, determine the value of "N" required to produce the overall time delay of 70  $\mu$ s.

[10 + 10 marks]

same:

(i) Register - Addressing mode:

MOV AX, BX

(ii) Direct Addressing mode:

MOV AX, 2000H

(iii) Indirect Addressing mode

EXI H, 2000H

3

(iv) Immediate Addressing mode:  
Direct data is part of the address.

MOV A, 20H.

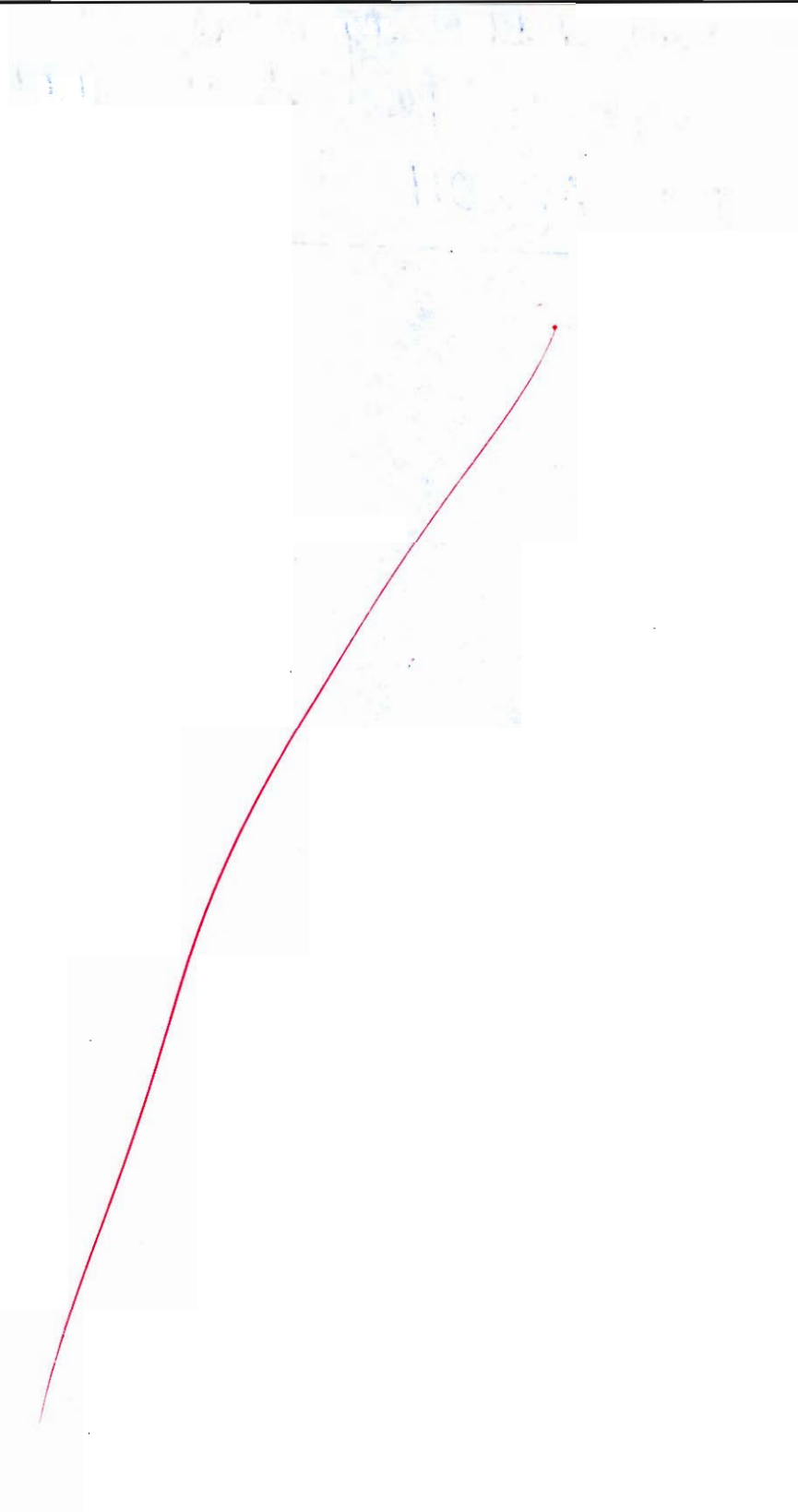

- (a) For the below resistive network, write a cut-set schedule and derive equilibrium equations for node voltages. Also, calculate values of branch voltages and branch currents.

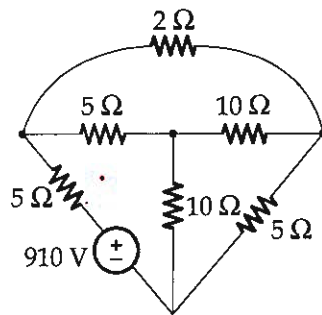

[20 marks]

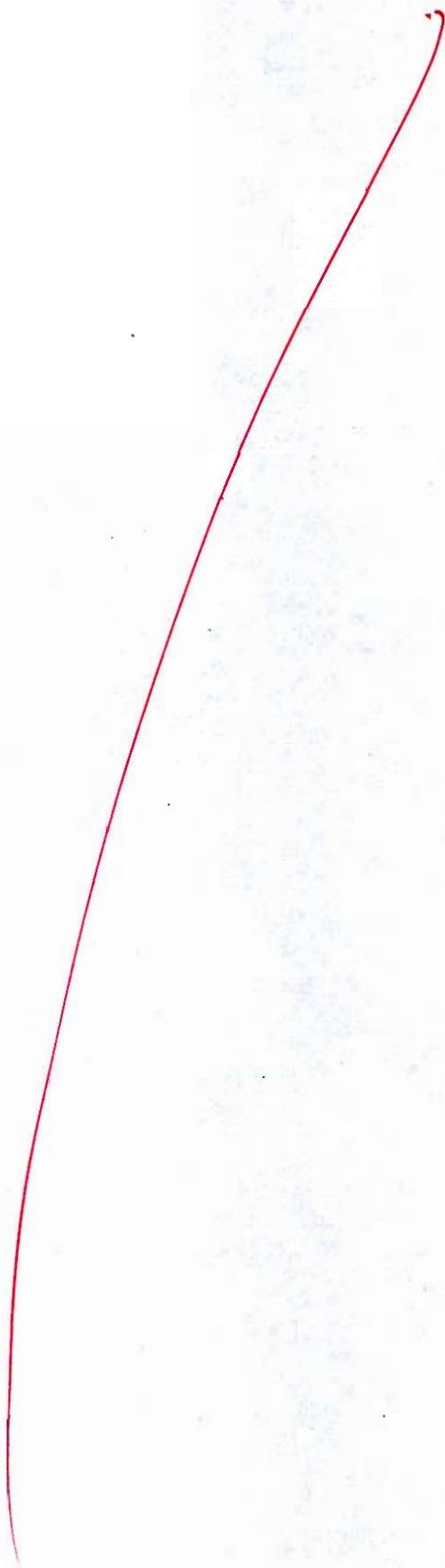

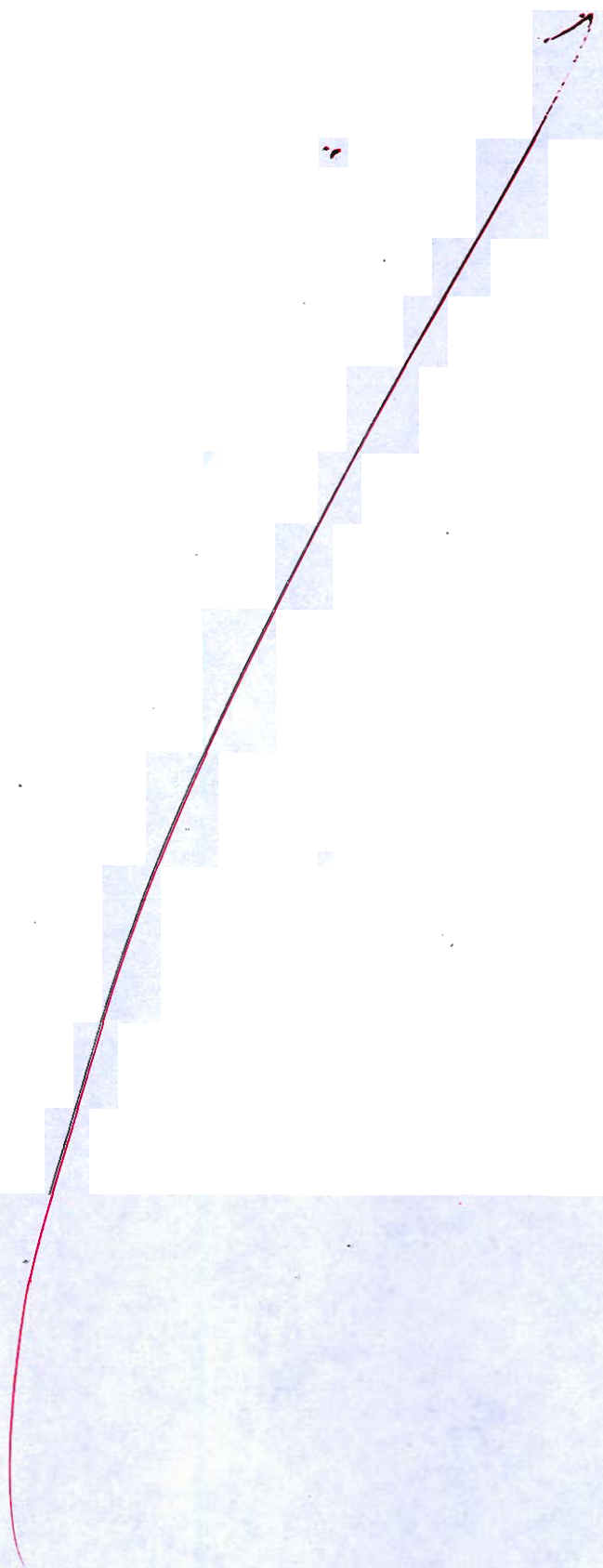

Q.7 (b) Given  $X(K) = \{255, 48.63 + j166.05, -51 + j102, -78.63 + j46.05, -85, -78.63 - j46.05, -51 - j102, 48.63 - j166.05\}$ . Determine  $x(n)$  using Inverse DIF FFT technique.

[20 marks]

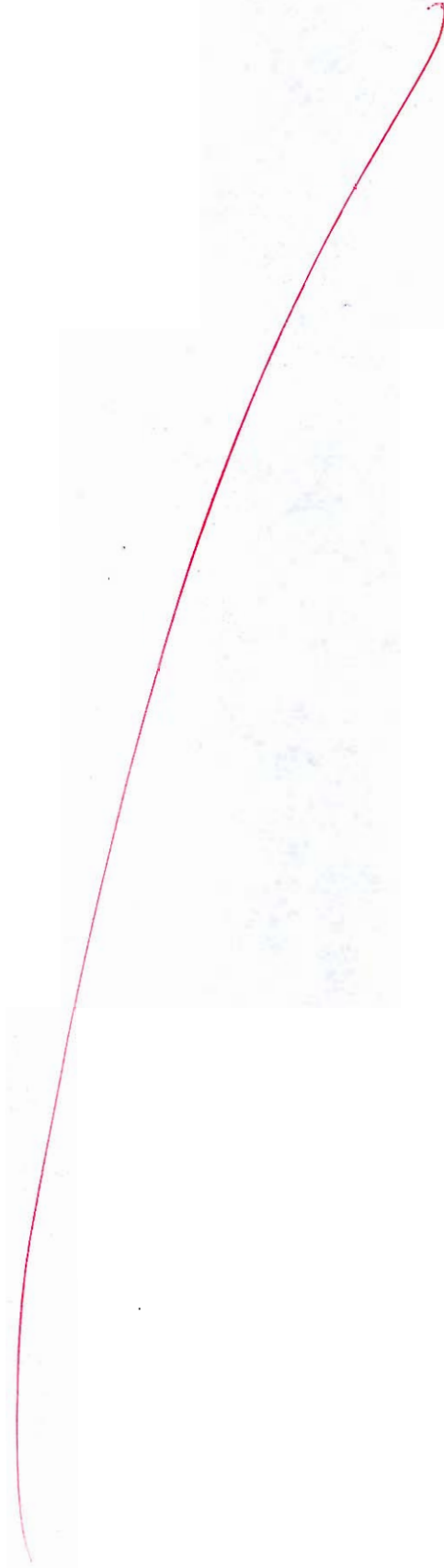

)

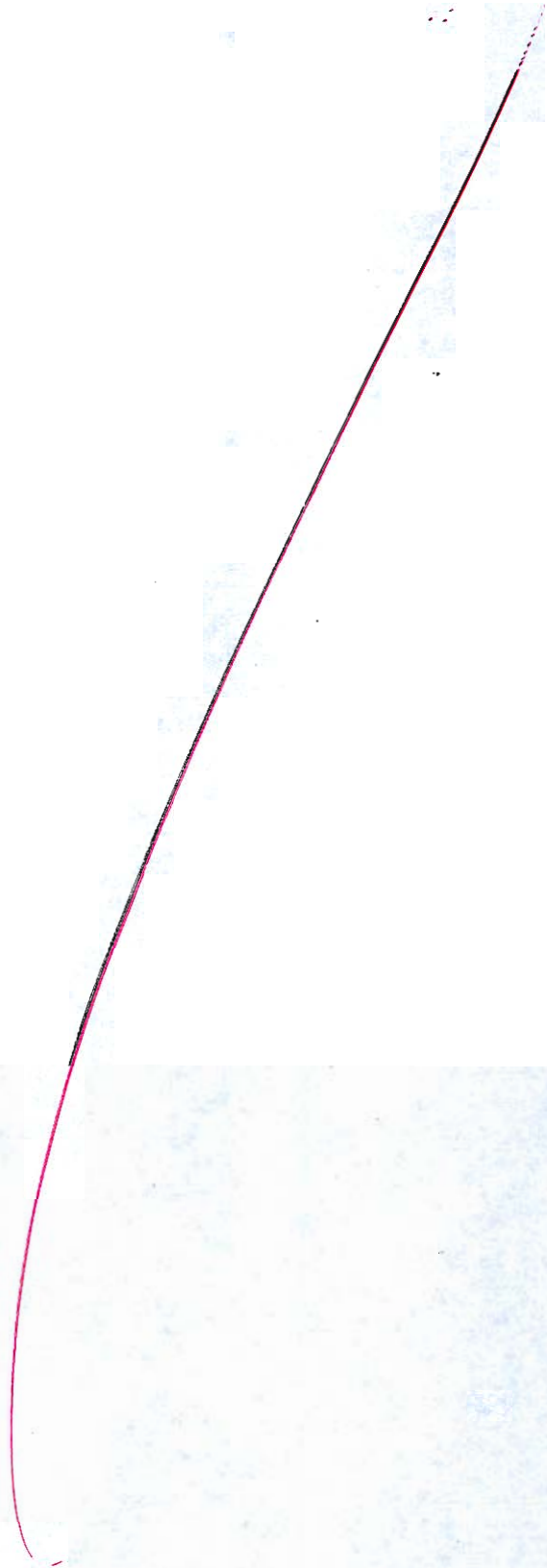

- Q.7 (c) (i) Consider the circuit shown in the figure below:

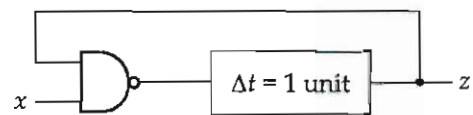
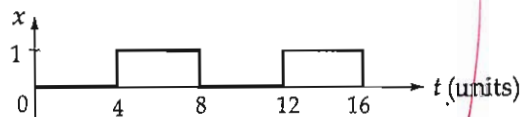

The input to the circuit is a periodic square wave with period 8 units. Plot the output  $z$  for 16 units of time.

- (ii) Derive a minimised POS expression for the given function.

$$f(A, B, C, D, E) = \prod M(0, 2, 4, 11, 14, 15, 16, 20, 24, 30, 31)$$

[10 + 10 marks]

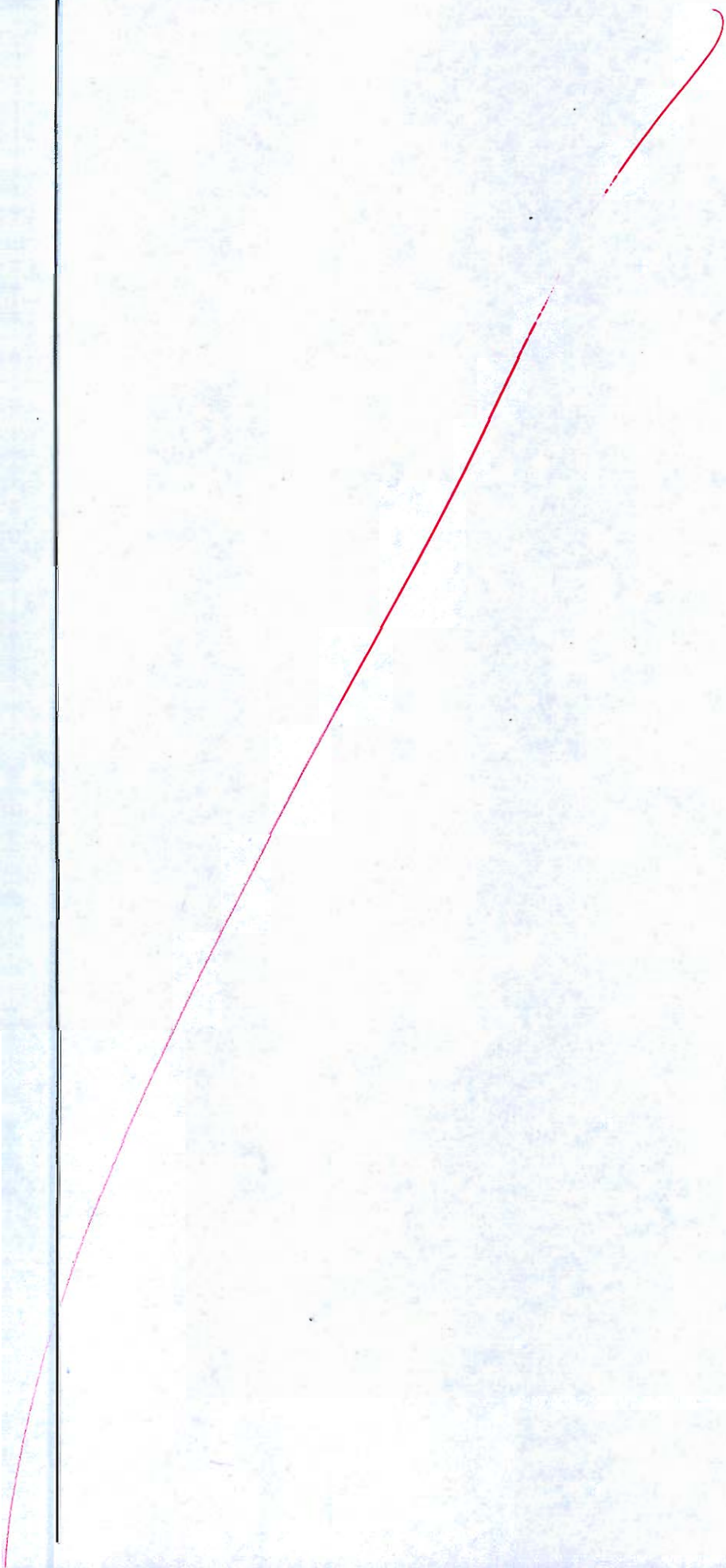

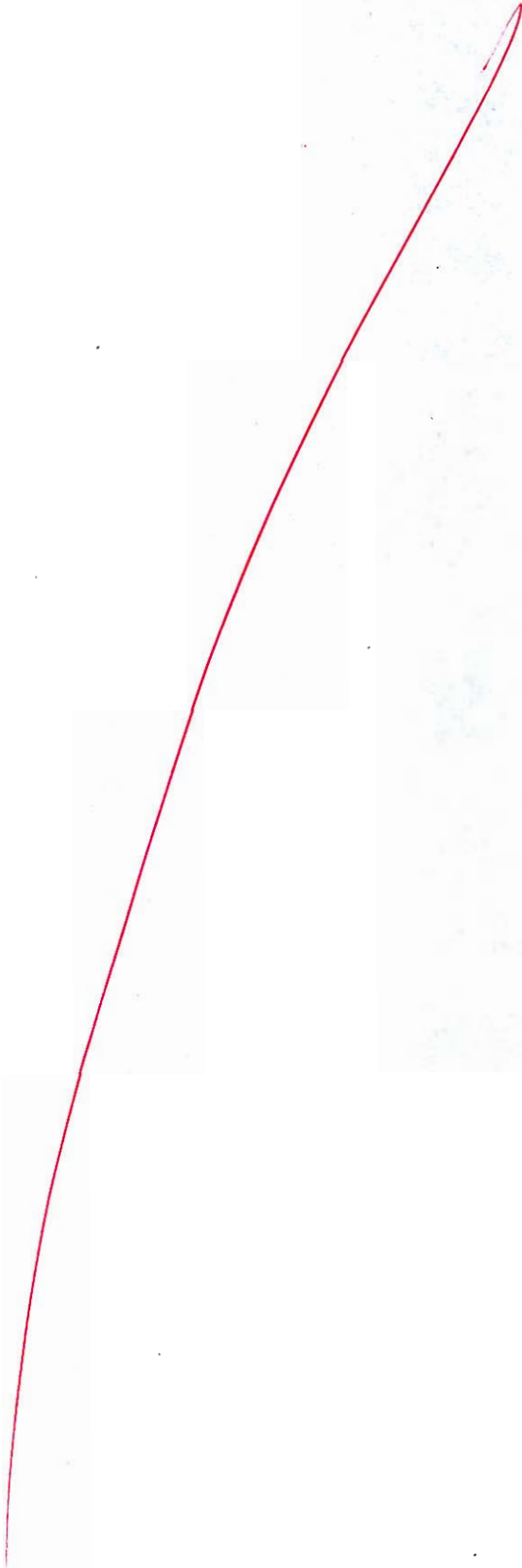

- (a) Given is the list of 50 different numbers which are stored in consecutive memory locations starting from 1000H. Write a program to search the given byte which is stored in the register 'C'. If the byte is found, then store the location of the byte in memory location 1100H and 1101H. If the byte is not found, then store the value 00H at 1100H and 1101H. Also, draw the flow chart for the given program which is to be written for 8085 microprocessor.

[20 marks]

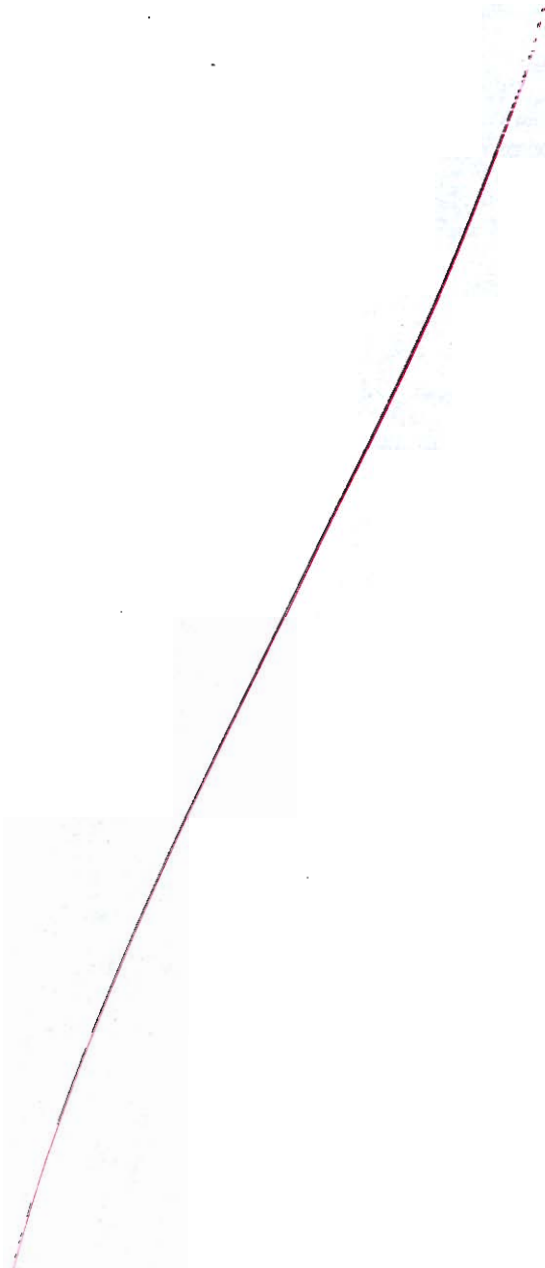

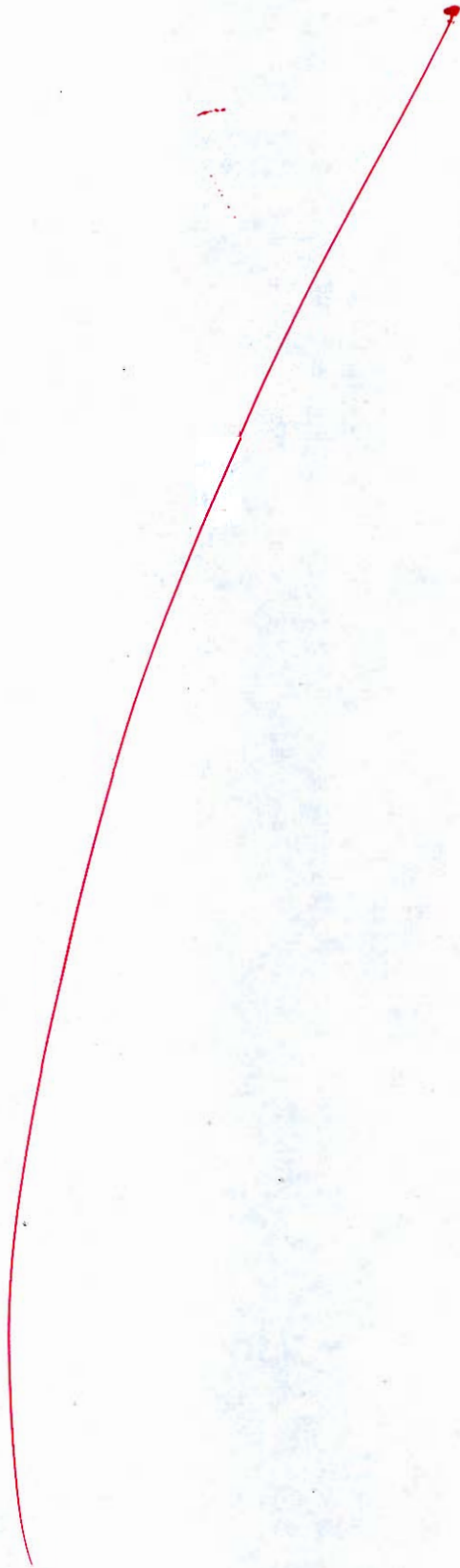

- b) (i) In a linear circuit consisting of  $R = 9 \Omega$  and  $L = 8 \text{ mH}$ , a current,  $i = 5 + 100\sin(1000t + 45^\circ) + 100 \sin(3000t + 60^\circ)\text{A}$  is flowing. Find the equation of applied voltage.
- (ii) Calculate the impedance consisting of  $R$  and  $L$  and the power factor of a circuit whose expression for voltage and current are  $v(t) = 250 \sin 314t + 50 \sin(942t + 30^\circ)\text{(V)}$  and  $i(t) = 17.7 \sin(314t - 45^\circ) + 1.583 \sin(942t - 41.6^\circ)\text{(A)}$ .

[10 + 10 marks]

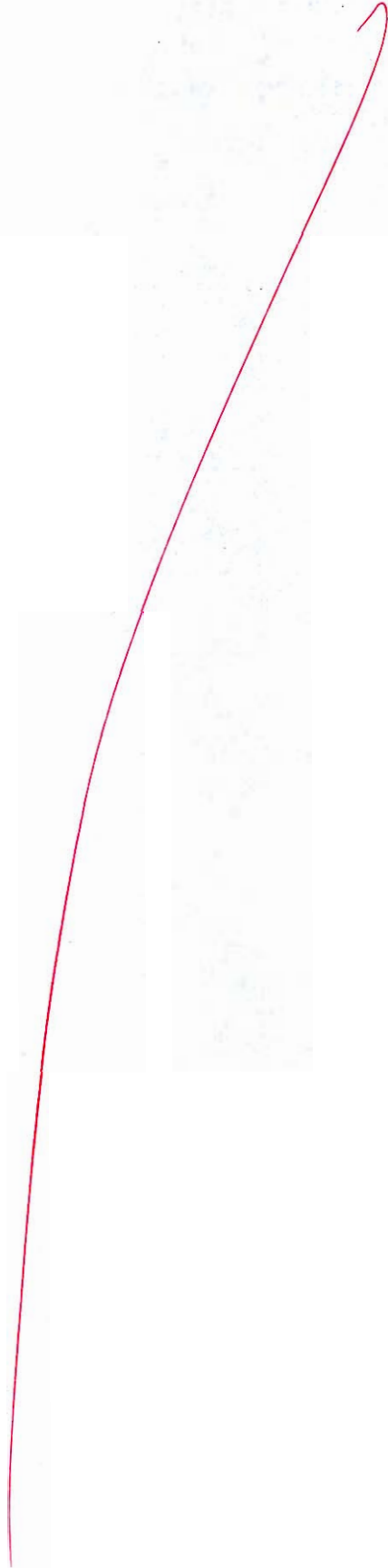

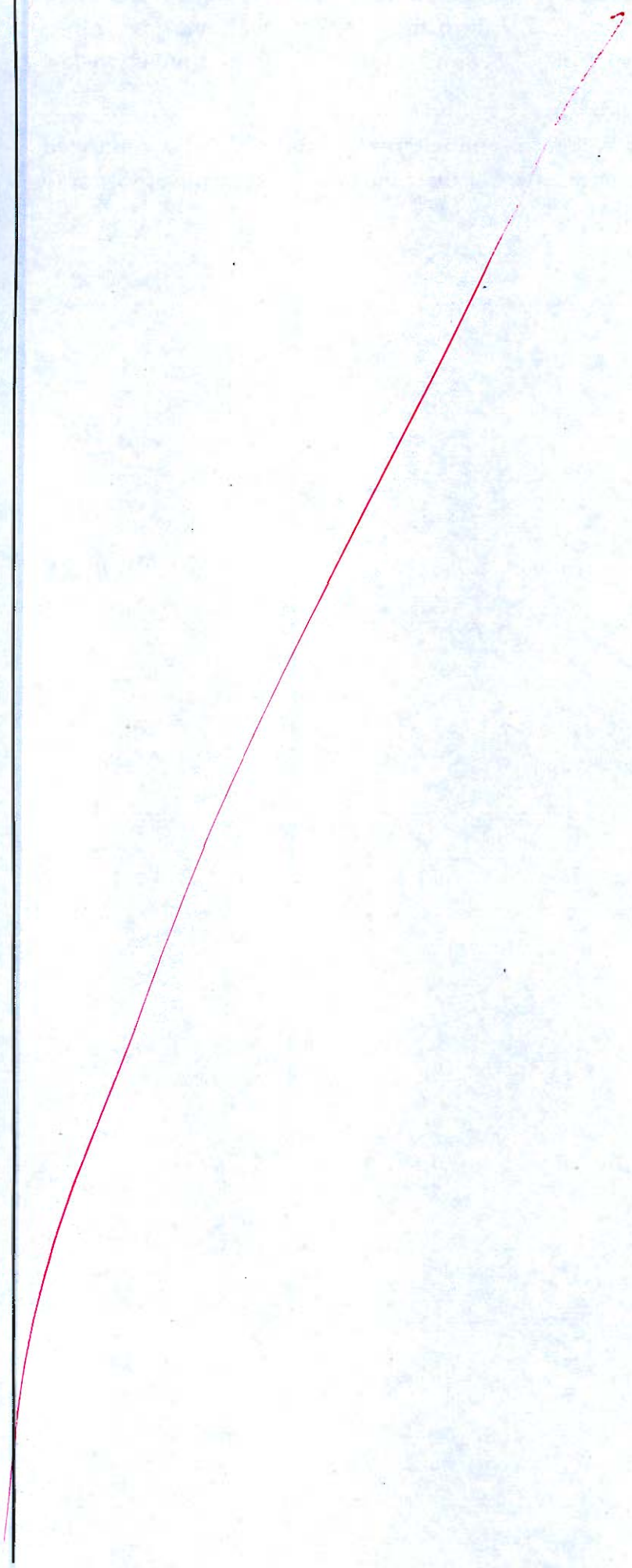

Q.8 (c) (i) Design a combinational circuit with three inputs  $x$ ,  $y$  and  $z$  and three outputs  $A$ ,  $B$  and  $C$ . When the binary input is 0, 1, 2 and 3, the binary output is one greater than the input. When the binary input is 4, 5, 6 and 7, then the binary output is two less than the input.

(ii) The 8085-microprocessor system has an external crystal of 5 MHz connected between its X1 and X2 pin terminals. Calculate the time taken by the processor to execute the following delay program.

```
DELAY: MVI D, 10 H
```

```
Loop 2: LXI B, 2030 H
```

```
Loop 1: DCX B
```

```
MOV A, C
```

```
ORA B
```

```
JNZ Loop 1
```

```
DCR D
```

```
JNZ Loop 2
```

```
RET
```

[10 + 10 marks]

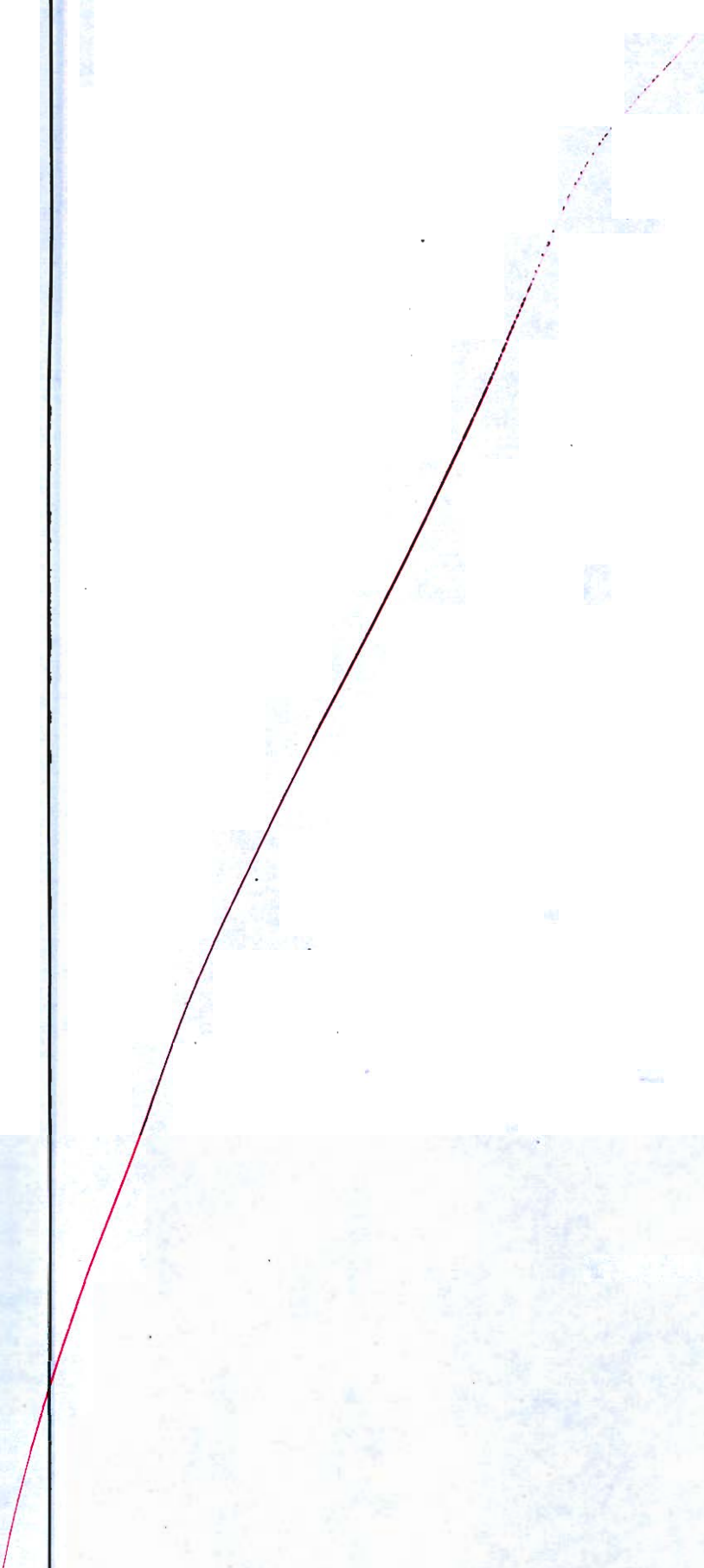



**Space for Rough Work**

---

**Space for Rough Work**

---

## Space for Rough Work

---

$$H(x) = \frac{\log_2 p_{xi}^0}{p_{xi}^0 (\log_2 \frac{1}{p_{xi}^0})}$$