



MADE EASY
India's Best Institute for IES, GATE & PSUs

Detailed Solutions

ESE-2024
Mains Test Series

Mechanical Engineering
Test No : 4

Section A : Theory of Machines [All Topics]

Section B : Fluid Mechanics & Turbo Machinery-1 [Part Syllabus]
Heat Transfer-2 + Refrigeration and Air-conditioning-2 [Part Syllabus]

Section : A

1. (a) (i)

Machine and Mechanism: If a number of bodies are assembled in such a way that the motion of one causes constrained and predictable motion to the others, it is known as a mechanism. A mechanism is a fundamental unit. A mechanism transmits and modifies a motion.

A machine is mechanism or a combination of mechanism which, apart from imparting definite motions to the parts, also transmits and modifies the available mechanical energy into some kind of desired work.

According to Grashof's Law of four-bar mechanism has at least one link to make a full revolution if the sum of the lengths of the largest and the shortest links is less than the sum of lengths of the other two links.

i.e. $S + L < P + Q$

Further, if the link adjacent to the shortest link is fixed, the chain acts as Crank-rocker mechanism in which the shortest link will revolve and the link adjacent to the fixed link will oscillate.

and if the shortest link is fixed, the chain will act as a double-crank mechanism in which the links adjacent to the fixed link will have complete revolutions.

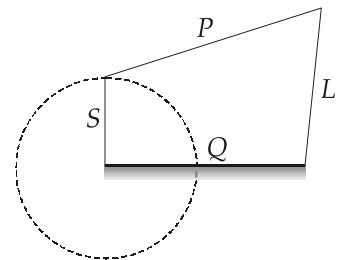

1. (a) (ii)

- **Double Slider-Crank Chain**

A kinematic chain consisting of two turning pairs and two sliding pairs is called double slider-crank chain as shown.

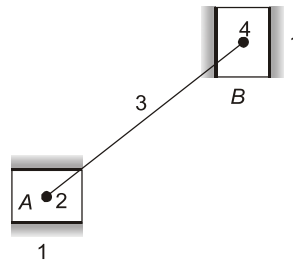

Double Slider-Crank chain

Inversions of Double slider crank chain

1. **First Inversion (Elliptical Trammel)** : It is a device to draw ellipses in which two grooves are cut at right angles in a plate that is fixed. The plate forms the fixed link 1. Two sliding blocks are fitted into the grooves. The slides form two sliding links 2 and 4. The link joining slides form the link 3. Any point on link 3 or on its extension traces out an ellipse on the fixed plate, when relative motion occurs.

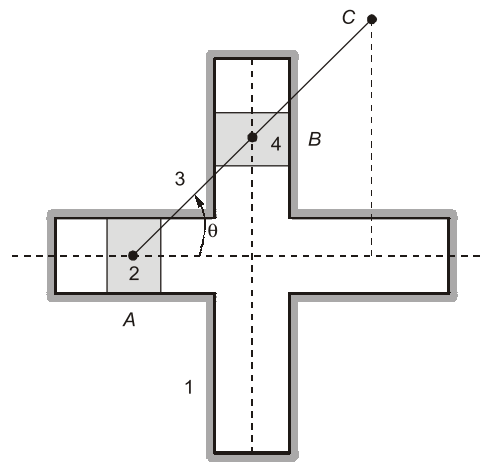

Elliptical Trammel

2. **Second Inversion (Scotch Yoke)** : If any of the slide-blocks of the first inversion is fixed, the second inversion of the double-slider-crank chain is obtained as shown in figure. This mechanism gives SHM. Its early application was on steam pumps, but it is now used as a mechanism on a test machine to produce vibrations. It is also used as a sine-cosine generator for computing elements.

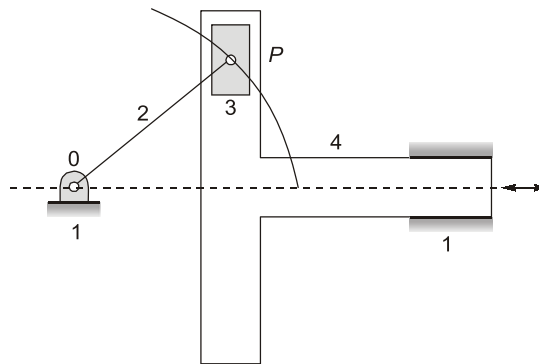

Scotch Yoke

3. **Third Inversion (Oldham's coupling) :** The Oldham's coupling is used to connect two parallel shafts, the distance between whose axes is small and variable. The shafts have flanges at the ends, in which slots are cut. These form links 2 and 4. An intermediate piece circular in shape and having tongues at right angles on opposite sides, is fitted between the flanges of the two shafts in such a way that the tongues of the intermediate piece get fitted in the slots of the flanges. The intermediate piece forms link 3, which slides or reciprocates in links 2 and 4. The link 1 is fixed.

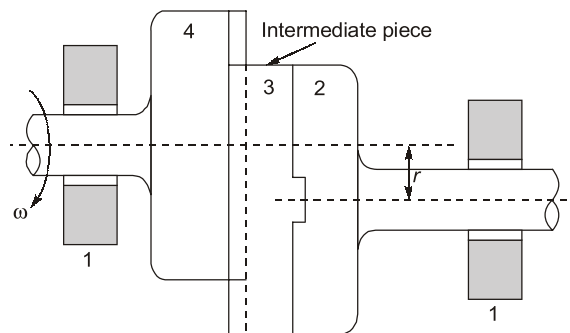

Oldham's coupling

1. (b)

$$D = 45 \text{ mm}; C_s = 0.035; t = 35 \text{ mm}; \text{Stroke} = 100 \text{ mm}; v = 25 \text{ m/s}$$

As 8 holes are punched in one minute, time required to punch one hole is 7.5s.

Energy required per hole or energy supplied by the motor in 7.5 seconds

$$= \text{Area of hole} \times \text{energy required} / \text{mm}^2$$

$$= \pi \times D \times t \times 9$$

$$= \pi \times 45 \times 35 \times 9 = 44532.07 \text{ Nm}$$

∴ Energy supplied by the motor in 1 seconds = $\frac{44532.07}{7.5} = 5937.61 \text{ Nm}$

∴ Power of the motor, $P = 5937.61 \text{ W}$ or 5.937 kW **Ans.**

The punch travels a distance of 200 mm in 7.5 seconds

∴ Actual time required to punch a hole in 35 mm thick plate = $\frac{7.5}{200} \times 35 = 1.3125\text{s}$

Assuming uniform velocity of the punch throughout energy supplied by the motor in actual time = $5937.61 \times 1.3125 = 7793.11 \text{ Nm}$

Energy supplied by the flywheel,

$$e = \text{Energy required per hole} - \text{Energy supplied by the motor in actual time.}$$

$$= 44532.07 - 7793.11$$

$$= 36738.96 \text{ Ns}$$

or $2C_s E = 36738.96$

$$2 \times 0.035 \times E = 36738.96$$

$$\Rightarrow E = 524842.28 \text{ Nm}$$

$$\Rightarrow \frac{1}{2} m V^2 = 524842.28$$

$$\Rightarrow m = \frac{2 \times 524842.28}{25^2}$$

$$\Rightarrow m = 1679.49 \text{ kg}$$

Ans.

1. (c) (i)

Flywheel	Governor
1. Function of a flywheel is to control the cyclic variation of speed due to the variation in power produced by an engine in a cycle.	1. Function of a governor is to control the speed of an engine due to variation in external load on the engine by changing the energy supply in the form of fuel
2. Flywheel regulates the speed during each cycle of engine operation.	2. Governor regulates the speed of engine when load varies over a time period.
3. Flywheel is operative in every cycle of the engine.	3. Governor operates only when load changes over the engine.
4. Flywheel stores the energy itself and gives out to engine during each cycle.	4. Governor regulates the fuel supply to the engine as per the load.
5. Flywheel has nothing to do for the quantity and quality of working medium.	5. Governor controls the speed by either quality or quantity variation of the working medium.
6. Mathematically a flywheel control the $\delta N / \delta t$.	6. A governor basically controls the δN .

1. (c) (ii)

Interference: A gear tooth has involute profile only outside the base circle. In fact, the involute profile begins at the base circle. In some cases, the dedendum is so large that it extends below this base circle. In such situations, the portion of the tooth below the base circle is not involute. The tip of the tooth on the mating gear, which is involute, interferes with this non-involute portion of the dedendum. This phenomenon of tooth profiles overlapping and cutting into each other is called 'interference'.

The following methods can eliminate interferences:

- **Increase Pressure Angle:** This results in smaller base circle so that more portion of the tooth profile becomes involute.
- **To use stub gears:** Reduced tooth depth gear, so that the addendum of gears is decreased.
- **Increase the centre distance between gear and pinion:** This will decrease the contacts of the addendums with the non-involute parts.

Undercutting : It is the phenomenon of cutting the non-involute root of the gear, due to interference. The non-involute part of gear is cut off during this process, which results in lowering the strength of teeth.

1. (d)

For N number of cylinders, the frequency of pressure vibration is given as =

$$\frac{N}{2} \times \text{Speed of engine} = \frac{1}{2} \times 540 \text{ rpm} = 270 \text{ rpm}$$

$$\omega = \frac{2\pi \times 270}{60} = 28.274 \text{ rad/s}$$

$$\text{Frequency of manometer} = \frac{28.274}{3.25} = 8.7 \text{ rad/s}$$

Kinetic energy of manometric fluid,

$$T = \frac{1}{2} m \dot{x}^2 = \frac{1}{2} \frac{\rho A l}{g} \dot{x}^2$$

$$\text{Potential energy, } V = \rho A x^2$$

where, ρ = weight per unit volume, A = cross-section area, l = length of fluid column

$$\text{Total energy} = T + V = \text{constant}$$

$$\text{So, } \frac{d}{dt}(T + V) = 0$$

$$\Rightarrow \frac{d}{dt} \left[\frac{1}{2} \frac{\rho A l \dot{x}^2}{g} + \rho A x^2 \right] = 0$$

$$\Rightarrow \frac{1}{2} \times \frac{\rho A l^2 \ddot{x}}{g} + \rho A 2x \dot{x} = 0$$

$$\Rightarrow \frac{l}{g} \dot{x} + 2x = 0$$

$$\Rightarrow \ddot{x} + \frac{2g}{l} x = 0$$

$$\Rightarrow \omega_n = \sqrt{\frac{2g}{l}}$$

But, we have,
$$\omega_n = 8.7 = \sqrt{\frac{2 \times 9.81}{l}}$$

$$l = 0.259 \text{ m}$$

Ans.

1. (e)

Force can only be transmitted from cam to follower or vice versa along the common normal or axis of transmission which is perpendicular to the axis of slip, or common tangent as shown below. The pressure angle ϕ is the angle between the direction of motion (velocity) of the follower and the direction of the axis of transmission. When $\phi = 0$, all the transmitted force goes into motion of the follower and none into slip velocity. When ϕ becomes 90° there will be no motion of the follower.

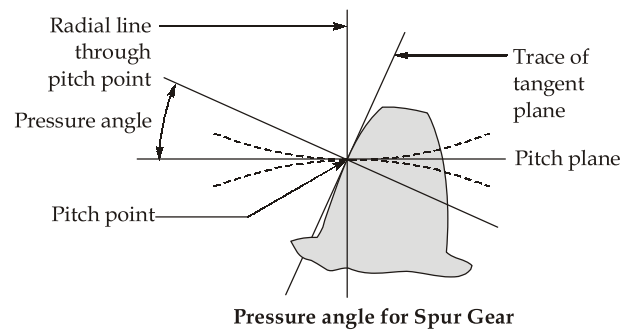
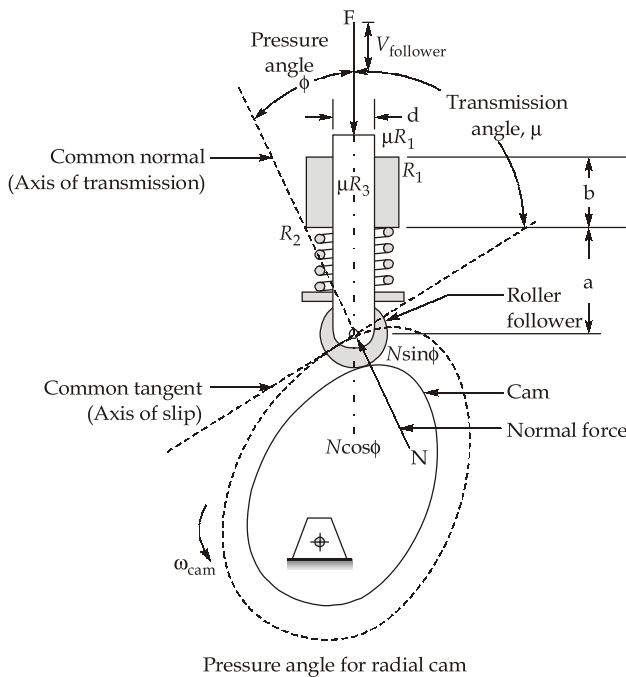

Pressure angle in relation to gear teeth, also known as the angle of obliquity, is the angle between the tooth face and the gear wheel tangent. It is more precisely the angle at

a pitch point between the line of pressure (which is normal to the tooth surface) and the plane tangent to the pitch surface. The pressure angle gives the direction normal to the tooth profile. The pressure angle is equal to the profile angle at the standard pitch circle and can be termed the "standard" pressure angle at that point.

2. (a)

$$M = 120 \text{ kg}; m_r = 2 \text{ kg}; L = 90 \text{ mm}; r = 45 \text{ mm}; F_T = \frac{1}{25} \times F_0; N = 900 \text{ rpm}$$

$$\omega = \frac{2 \times \pi \times 900}{60} = 94.25 \text{ rad/s}$$

Neglecting damping $\xi = 0$

$$\text{Transmissibility, } \epsilon_T = \frac{F_T}{F_0} = \frac{\sqrt{1 + \left(\frac{2\xi\omega}{\omega_n}\right)^2}}{\sqrt{\left(1 - \left(\frac{\omega}{\omega_n}\right)^2\right)^2 + \left(\frac{2\xi\omega}{\omega_n}\right)^2}}$$

$$\frac{1}{25} = \frac{1}{\pm \left[1 - \left(\frac{\omega}{\omega_n}\right)^2\right]}$$

$$\Rightarrow \pm \left[1 - \left(\frac{\omega}{\omega_n}\right)^2\right] = 25$$

Taking positive sign into consideration,

$$\Rightarrow 1 - \left(\frac{\omega}{\omega_n}\right)^2 = 25$$

$$\Rightarrow \frac{\omega}{\omega_n} = \sqrt{-24} \text{ which is not possible}$$

Taking negative sign into consideration,

$$\Rightarrow - \left[1 - \left(\frac{\omega}{\omega_n}\right)^2\right] = 25$$

$$\Rightarrow -1 + \left(\frac{\omega}{\omega_n}\right)^2 = 25$$

$$\Rightarrow \left(\frac{\omega}{\omega_n} \right)^2 = 26$$

$$\Rightarrow \frac{\omega}{\omega_n} = \sqrt{26} = 5.1$$

$$\Rightarrow \omega_n = \frac{94.25}{5.1} = 18.48 \text{ rad/s}$$

$$\omega_n = \sqrt{\frac{s_{eq}}{M}}$$

$$\Rightarrow s_{eq} = 18.48^2 \times M = 18.48^2 \times 120$$

$$\Rightarrow s_{eq} = 40981.25 \text{ N/m}$$

Ans.

The unbalance force on the machine due to reciprocating part,

$$(i) F_0 = m_r \cdot r \cdot \omega^2 = 2 \times 0.045 \times 94.25^2 = 799.47 \text{ N}$$

$$\frac{x_0}{x_1} = \frac{1}{0.70} = e^\delta \text{ (Given)}$$

$$\Rightarrow \ln\left(\frac{1}{0.7}\right) = \ln e^\delta$$

$$\Rightarrow \delta = 0.3567$$

Also, logarithmic decrement, $\delta = \frac{2\pi\xi}{\sqrt{1-\xi^2}}$

$$\Rightarrow 0.3567 = \frac{2\pi\xi}{\sqrt{1-\xi^2}}$$

Solving above equation, we get

$$\xi = 0.0567$$

$$\therefore \text{Transmissibility, } \epsilon_T = \frac{F_T}{F_0} = \frac{\sqrt{1 + (2 \times 0.0567 \times 5.1)^2}}{\sqrt{(1 - 5.1^2)^2 + (2 \times 0.0567 \times 5.1)^2}}$$

$$\Rightarrow \frac{F_T}{799.47} = 0.04617$$

$$\Rightarrow F_T = 36.91 \text{ N}$$

Ans.

(ii) The unbalance force on the machine due to reciprocating machining at resonance,

$$(F_0)_{\text{reso}} = m_r \cdot r \cdot \omega_n^2 = 2 \times 0.045 \times 18.48^2 = 30.73 \text{ N}$$

$$(\epsilon_T)_{\text{reso}} = \frac{\sqrt{1 + (2\xi)^2}}{\sqrt{(2\xi)^2}} = \frac{\sqrt{1 + (2 \times 0.0567)^2}}{2 \times 0.0567}$$

$$\Rightarrow \frac{(F_T)_{reso}}{30.73} = 8.875$$

$$\Rightarrow (F_T)_{reso} = 272.73 \text{ N} \quad \text{Ans.}$$

(iii) Amplitude of forced vibration at resonance,

$$A_{reso} = \frac{F_0/s}{2\xi} = \frac{30.73/40981.25}{2 \times 0.0567}$$

$$= 6.612 \times 10^{-3} \text{ m} \quad \text{Ans.}$$

2. (b) (i)

The arc of contact is the distance travelled by a point on either pitch circle of the two wheels during the period of contact of a pair of teeth.

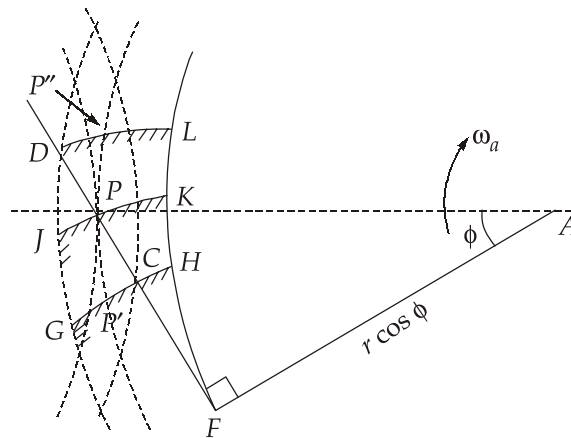

In figure, at the beginning of engagement, the driving involute is shown as GH; when the point of contact is at P, it is shown as JK and when at the end of engagement, it is DL. The arc of contact is P'P'' and it consists of the arc or approach P'P and the arc of recess PP''.

Let the time to traverse the arc of approach is t_a .

Then Arc of approach = P'P = Tangential velocity of P' \times Time of approach

$$= \omega_a r \times t_a \quad (t_a = \text{time of approach})$$

$$= \omega_a (r \cos \phi) \frac{1}{\cos \phi} t_a$$

$$= (\text{Tang. velocity of H}) t_a \frac{1}{\cos \phi}$$

$$= \frac{\text{Arc HK}}{\cos \phi} = \frac{\text{Arc FK} - \text{Arc FH}}{\cos \phi}$$

$$= \frac{FP - FC}{\cos\phi} = \frac{CP}{\cos\phi}$$

Arc FK is equal to the path FP as the point P is on the generator FP that rolls on the base circle FHK to generate the involute PK. Similarly, arc FH = Path FC

$$\text{Arc of recess} = PP'' = \text{Tang. velocity of P} \times \text{Time of recess}$$

$$= \omega_a r \times t_r \quad (t_r = \text{time of recess})$$

$$= \omega_a (r \cos\phi) \frac{1}{\cos\phi} t_r$$

$$= (\text{Tang. velocity of K}) t_r \frac{1}{\cos\phi}$$

$$= \frac{\text{Arc KL}}{\cos\phi} = \frac{\text{Arc FL} - \text{Arc FK}}{\cos\phi}$$

$$= \frac{FP - FC}{\cos\phi} = \frac{CP}{\cos\phi}$$

$$PP'' = \frac{FD - FP}{\cos\phi} = \frac{PD}{\cos\phi}$$

$$\text{Arc of contact} = \frac{CP}{\cos\phi} + \frac{PD}{\cos\phi} = \frac{CP + PD}{\cos\phi} = \frac{CD}{\cos\phi}$$

or

$$\text{Arc of contact} = \frac{\text{Path of contact}}{\cos\phi}$$

2. (b) (ii)

Given : $\phi = 20^\circ$; $t = T = 54$; $m = 8$ mm; $R = r = \frac{mT}{2} = \frac{8 \times 54}{2} = 216$ mm

$$\text{Arc of contact} = 2.3 \times \text{Circular pitch}$$

$$= 2.3 \times \pi \times 8$$

$$= 57.805 \text{ mm}$$

$$\text{Path of contact} = \text{Arc of contact} \times \cos\phi$$

$$= 57.805 \times \cos 20^\circ$$

$$= 54.32 \text{ mm}$$

Since, both gears having equal numbers of teeth so, the path approach is equal to path of recess.

$$\therefore \text{Path of contact} = 2 \times \left[\sqrt{R_A^2 - (R \cos\phi)^2} - R \sin\phi \right]$$

$$\Rightarrow 54.32 = 2 \times \left[\sqrt{R_A^2 - (216 \times \cos 20^\circ)^2} - 216 \times \sin 20^\circ \right]$$

$$\Rightarrow R_A = 226.73 \text{ mm}$$

$$\therefore \text{Addendum} = R_A - R = 226.73 - 216 = 10.73 \text{ mm}$$

Ans.**2. (c)**

Given : $I_2 = 3 \text{ g-m}^2 = 3 \times 10^{-3} \text{ kg-m}^2$; $\alpha = 25^\circ$; $N_1 = 2700 \text{ rpm}$; $T_{\text{mean}} = 280 \text{ Nm}$

Angular velocity of driving shaft,

$$\omega_1 = \frac{2\pi N_1}{60} = \frac{2\pi \times 2700}{60} = 282.74 \text{ rad/s}$$

For angular acceleration to be maximum or minimum

$$\Rightarrow \cos 2\theta = \frac{2 \sin^2 \alpha}{2 - \sin^2 \alpha} = \frac{2 \sin^2 25^\circ}{2 - \sin^2 25^\circ}$$

$$2\theta = 78.69^\circ; 281.31^\circ$$

$$\theta = 39.345^\circ; 140.655^\circ$$

Taking $\theta_1 = 39.345^\circ$ and $\theta_2 = 140.655^\circ$

Angular velocity at driven shaft,

$$\omega_2 = \frac{\omega_1 \cos \alpha}{1 - \cos^2 \theta \sin^2 \alpha}$$

$$(\omega_2)_{\theta_1} = \frac{282.74 \times \cos 25^\circ}{1 - \cos^2(39.345^\circ) \sin^2 25^\circ}$$

$$(\omega_2)_{\theta_1} = 286.89 \text{ rad/s}$$

Similarly at $\theta_2 = 140.655^\circ$

$$(\omega_2)_{\theta_2} = \frac{282.74 \times \cos 25^\circ}{1 - \cos^2(140.655^\circ) \sin^2 25^\circ}$$

$$(\omega_2)_{\theta_2} = 286.89 \text{ rad/s}$$

At $\theta_1 = 39.345^\circ$

Angular acceleration at driven shaft,

$$\begin{aligned} \alpha_2 &= \frac{-\omega^2 \cos \alpha \sin 2\theta \sin^2 \alpha}{(1 - \cos^2 \theta \sin^2 \alpha)^2} \\ &= \frac{-282.74^2 \cos 25^\circ \sin(2 \times 39.345^\circ) \sin^2(25^\circ)}{(1 - \cos^2 39.345^\circ \sin^2 25^\circ)^2} \\ &= -15905.56 \text{ rad/s}^2 \end{aligned}$$

$$\begin{aligned} \text{Inertia torque at driven shaft} &= I_2 \alpha_2 \\ &= 3 \times 10^{-3} \times (-15905.56) \\ &= -47.72 \text{ Nm} \end{aligned}$$

$$\begin{aligned} \text{Total torque} \Rightarrow T_2 - T_{\text{mean}} &= I_2 \alpha_2 \\ \Rightarrow (T_2)_{\text{min}} &= T_{\text{mean}} + I_2 \alpha_2 \\ &= 280 + (-47.72) = 232.28 \text{ Nm} \end{aligned} \quad \text{Ans.}$$

$$\begin{aligned} \text{For } \eta = 100\% \Rightarrow T_1 \omega_1 &= T_2 \omega_2 \\ (T_1)_{\text{min}} &= \frac{(T_2)_{\text{min}} \times \omega_2}{\omega_1} = \frac{232.28 \times 286.89}{282.74} \\ &= 235.69 \text{ Nm} \end{aligned} \quad \text{Ans.}$$

Similarly at $\theta_2 = 140.655^\circ$

$$\begin{aligned} \alpha_2 &= \frac{-282.74^2 \times \cos 25^\circ \times \sin(2 \times 140.655^\circ) \times \sin^2(25^\circ)}{(1 - \cos^2 140.655^\circ \sin^2 25^\circ)^2} \\ &= 15905.56 \text{ rad/s}^2 \end{aligned}$$

$$\begin{aligned} \text{Inertia torque at driven shaft} &= I_2 \alpha_2 \\ &= 3 \times 10^{-3} \times 15905.56 \\ &= 47.72 \text{ Nm} \end{aligned}$$

$$\begin{aligned} \therefore T_2 - T_{\text{mean}} &= I_2 \alpha_2 \\ \Rightarrow (T_2)_{\text{max}} &= 280 + 47.72 = 327.72 \text{ Nm} \end{aligned} \quad \text{Ans.}$$

$$\begin{aligned} (T_1)_{\text{max}} &= \frac{(T_2)_{\text{max}} \times \omega_2}{\omega_1} = \frac{327.72 \times 286.89}{282.74} \\ &= 332.53 \text{ Nm} \end{aligned} \quad \text{Ans.}$$

3. (a)

Given : $H = 220 \text{ cm} = 2.2 \text{ m}$; $B = 80 \text{ cm} = 0.8 \text{ m}$; $t = 5 \text{ cm} = 0.05 \text{ m}$; $m = 40 \text{ kg}$;

$k_t = 2 \text{ kg-cm/radian} = 2 \times 9.81 \times 10^{-2} = 0.1962 \text{ N-m/radian}$

For a critically damped system the equation of motion can be written as,

$$x = (A_1 + A_2 t) e^{-\omega_n t} \quad \dots(\text{i})$$

Differentiating above equation w.r.t. time, we get

$$\dot{x} = \frac{dx}{dt} = -\omega_n (A_1 + A_2 t) e^{-\omega_n t} + e^{-\omega_n t} \cdot A_2$$

$$\Rightarrow \dot{x} = e^{-\omega_n t} [A_2 - \omega_n (A_1 + A_2 t)] \quad \dots(\text{ii})$$

As given in question, at $t = 0$, $x = \frac{\pi}{2}$ and $\dot{x} = 0$

$$\frac{\pi}{2} = (A_1 + A_2 \times 0) \times e^{-\omega_n \times 0}$$

$$\Rightarrow A_1 = \frac{\pi}{2}$$

$$0 = e^{-\omega_n \times 0} [A_2 - \omega_n (A_1 + A_2 \times 0)]$$

$$\Rightarrow A_2 = \frac{\pi \omega_n}{2}$$

So, substituting the values of A_1 and A_2 in equation (i), we get

$$x = \left(\frac{\pi}{2} + \frac{\pi \omega_n t}{2} \right) \times e^{-\omega_n t} = \frac{\pi}{2} (1 + \omega_n t) e^{-\omega_n t}$$

Also,
$$2^\circ \times \frac{\pi}{180^\circ} = \frac{\pi}{2} (1 + \omega_n t) e^{-\omega_n t}$$

$$\frac{1}{45} = (1 + \omega_n t) e^{-\omega_n t}$$

Solving above equation, we get

$$\omega_n t = 5.71$$

The frequency of vibration is given by,

$$\omega_n = \sqrt{\frac{k_t}{I_{xx}}} = \sqrt{\frac{0.1962}{19.25}} = 0.10095 \text{ rad/s}$$

We know that,

$$\omega_n t = 5.71$$

$$\Rightarrow t = \frac{5.71}{0.10095} = 56.56 \text{ sec}$$

Ans.

3. (b)

Given : $N_{BO_1} = 40 \text{ rpm}$

$$\omega_{BO_1} = \frac{2\pi N_{BO_1}}{60} = \frac{2\pi \times 40}{60} = 4.18 \text{ rad/s}$$

The point B is one the crank O_1B .

The velocity of point B w.r.t. O_1 ,

$$V_{OB_1} = \omega_{BO_1} \times O_1B = 4.18 \times 0.3 = 1.254 \text{ m/s}$$

The point C is on the link O_2D as shown in figure.

The velocity diagram are shown below.

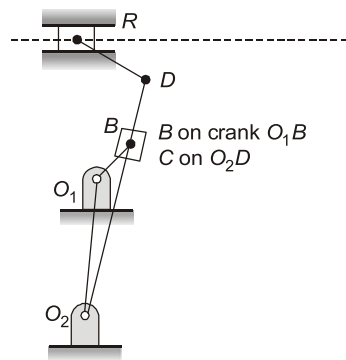

(b) Line diagram

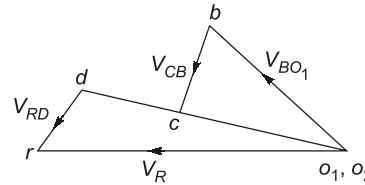

(c) Velocity diagram

The following procedures are followed to construction velocity diagram:

- (a) The point O_1 and O_2 are fixed on the configuration diagram, so they may be taken as one (o_1o_2) on the velocity diagram.
- (b) Draw point o_1b perpendicular to O_1B with magnitude 1.254 m/s (taking suitable scale).
- (c) The velocity of point C with respect to B, V_{CB} is along O_2D , the path of motion of the sliding block. Thus, draw vector bc representing V_{CB} from point b . It contains point c .
- (d) The velocity of point C with respect to fixed point O_2 , V_{CO_2} is perpendicular to O_2C from o_1 draw vector o_1c representing V_{CO_2} . It intersects vector bc at point c . Extend vector o_1c to o_1d such that

$$\frac{o_2c}{o_2d} = \frac{o_1c}{o_1d} = \frac{O_2C}{O_2D}$$

- (e) The velocity of point R with respect to D, V_{RD} is perpendicular to DR. From draw vector dr representing V_{RD} . It contains point r .
- (f) The velocity of point R on the ram with respect to fixed point O_1 or O_2 , V_{RO_1} or V_R is along the path of the slider R. From point o_1 draw vector o_1r representing V_R . It intersect dr at r .

- (g) Join r to o_1 . Thus $o_1r = V_R$. By measurement $o_1r = V_R = 1.42$ m/s **Ans**

Angular velocity of link O_2D ,

$$\omega_{O_2D} = \frac{V_{O_2D}}{O_2D} = \frac{o_2d}{O_2D} = \frac{1.3}{1.3} = 1 \text{ rad/s} \quad \text{Ans.}$$

[$\because o_2d = 1.3$ m/s by measuring]

3. (c)

$$\text{Given : } l = 240 \text{ mm; } L_s = 120 \text{ mm; } r = \frac{L_s}{2} = \frac{120}{2} = 60 \text{ mm; } m_{\text{reci}} = 1.2 \text{ kg; } n = \frac{l}{r} = \frac{240}{60} = 4$$

The position of the two cylinders is shown below:

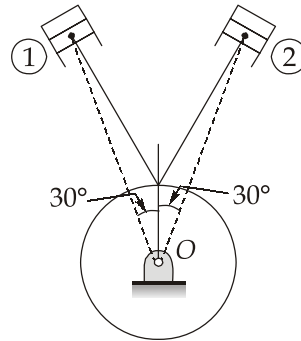

Primary direct crank

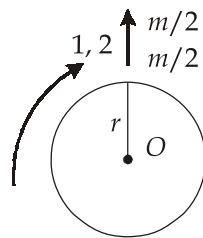

Primary reverse crank

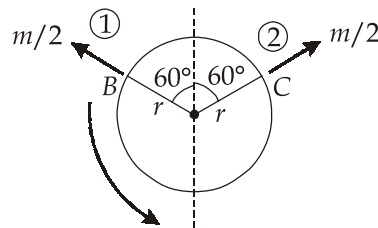

$$\therefore \omega = \frac{2\pi N}{60} = \frac{2\pi \times 3000}{60} = 314.16 \text{ rpm}$$

$$\begin{aligned} \text{Primary force due to direct cranks} &= 2 \times \left(\frac{m}{2}\right) r \omega^2 \\ &= 2 \times \left(\frac{1.2}{2}\right) \times 0.06 \times (314.16)^2 = 7106.15 \text{ N} \end{aligned}$$

$$\begin{aligned} \text{Primary force due to reverse crank} &= 2 \times \left(\frac{m}{2}\right) r \omega^2 \times \cos 60^\circ \\ &= 2 \times \left(\frac{1.2}{2}\right) \times 0.06 \times (314.16)^2 \times \cos 60^\circ \\ &= 3553.07 \text{ N} \end{aligned}$$

$$\begin{aligned} \therefore \text{Total primary force} &= 7106.12 + 3553.07 \\ &= 10659.19 \text{ N} \end{aligned}$$

Ans

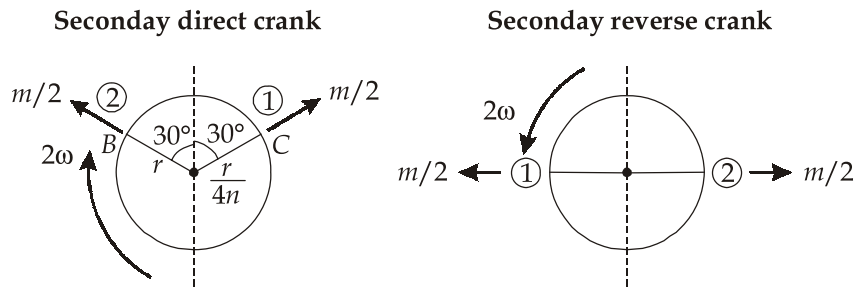

Thus, the secondary unbalanced force

$$\begin{aligned}
 &= 2 \times \left(\frac{mr\omega^2 \cos 30^\circ}{2n} \right) \\
 &= \frac{1.2 \times 0.06 \times 314.16^2 \cos 30^\circ}{4} = 1538.52 \text{ N}
 \end{aligned}$$

4. (a)

Given : $I_w = 2.5 \text{ kgm}^2$; $I_e = 1.25 \text{ kgm}^2$; $m = 2500 \text{ kg}$; $r = 0.32 \text{ m}$; $h = 0.56 \text{ m}$; $w = 1.6 \text{ m}$;

$$G = \left(\frac{\omega_e}{\omega_w} \right) = 3; R = 80 \text{ m}$$

(i) Reaction due to weight, $R_w = \frac{mg}{4} = \frac{2500 \times 9.81}{4} = 6131.25 \text{ N (upward)}$

(ii) Reaction due to gyroscopic couple,

$$C_w = 4I_w \omega_w \omega_p$$

$$C_w = \frac{4I_w V^2}{rR} = 4 \times 2.5 \times \frac{V^2}{0.32 \times 80} = 0.3906 \times V^2$$

$$C_e = I_e \omega_e \omega_p$$

$$C_e = 1.25 \times 3 \times \frac{V^2}{0.32 \times 80} = 0.1465 \times V^2$$

$$\therefore C_G = C_w + C_e = 0.3906 \times V^2 + 0.1465V^2 = 0.5371V^2$$

Reaction on each outer wheel,

$$R_{Go} = \frac{C_G}{2w} = \frac{0.5371 \times V^2}{2 \times 1.6} = 0.1678V^2 \text{ (upwards)}$$

Reaction on each inner wheel,

$$R_{Gi} = 0.1678V^2 \text{ (downwards)}$$

(iii) Reaction due to centrifugal couple,

$$C_c = \frac{mV^2}{R} \times h = \frac{2500 \times V^2}{80} \times 0.56 = 17.5V^2$$

Reaction on each outer wheel,

$$R_{Co} = \frac{C_c}{2w} = \frac{17.5V^2}{2 \times 1.6} = 5.4687 \times V^2 \text{ (upwards)}$$

Reaction on each inner wheel,

$$R_{Ci} = 5.4687 \times V^2 \text{ (downwards)}$$

For maximum safe speed, the condition,

$$R_w = R_{Gi} + R_{Ci}$$

$$\Rightarrow 6131.25 = 5.4687 \times V^2 + 0.1678V^2$$

$$V = 32.98 \text{ m/s or } 32.98 \times \frac{3600}{1000} = 118.73 \text{ km/h}$$

4. (b)

$$\omega = \frac{2\pi \times 390}{60} = 40.84 \text{ rad/s}$$

(i) Considering the friction at the mid-position

$$mr\omega_1^2 \times a = \frac{1}{2}(Mg + F_s + f) \times b$$

Since, $a = b$

$$\Rightarrow m \times 0.08 \times (40.84 \times 1.01)^2 = \frac{1}{2} \times (6 \times 9.81 + F_s + 36) \quad \dots(i)$$

Also,
$$mr\omega_2^2 \times a = \frac{1}{2}(Mg + F_s - f)b$$

$$\Rightarrow m \times 0.08 \times (40.84 \times 0.99)^2 = \frac{1}{2} \times (6 \times 9.81 + F_s - 36) \quad \dots(ii)$$

Subtracting equation (ii) and (i), we get

$$\Rightarrow m \times 0.08 \times 40.84^2 \times [(1.01)^2 - (0.99)^2] = \frac{1}{2} \times (36 + 36)$$

$$\Rightarrow m \times 5.337 = 36$$

$$\Rightarrow m = 6.745 \text{ kg} \quad \text{Ans.}$$

(ii) In extreme positions,

$$mr_2\omega_2^2 \times a = \frac{1}{2}(mg + F_{s2} + f) \times b$$

Since, $a = b$

$$\Rightarrow 6.745 \times (0.08 + 0.02) \times (40.84 \times 1.05)^2 = \frac{1}{2}(6 \times 9.81 + F_{s_2} + 35)$$

$$F_{s_2} = 2386.77 \text{ N}$$

Similarly,

$$m_1 r_1 \omega_1^2 \times a = \frac{1}{2}(mg + F_{s_1} - f) \times b$$

$$6.745 \times (0.08 - 0.02) \times (40.84 \times 0.95)^2 = \frac{1}{2}(6 \times 9.81 + F_{s_1} - 35)$$

$$F_{s_1} = 1194.52 \text{ N}$$

$$\text{Spring stiffness, } s = \frac{F_{s_2} - F_{s_1}}{\Delta h} = \frac{2386.77 - 1194.52}{0.04}$$

$$= 29806.25 \text{ N/m}$$

Ans.

(iii) Initial compression, $x_1 = \frac{F_{s_1}}{s} = \frac{1194.52}{29806.25}$

$$= 0.04007 \text{ m or } 40.076 \text{ mm}$$

Ans.

4. (c)

(i)

Cycloidal Teeth	Involute Teeth
1. Pressure angle varies from maximum at the beginning of engagement, reduces to zero at pitch point and again increases to maximum at the end of engagement resulting in less smooth running of the gears.	1. Pressure angle is constant throughout the engagement of teeth. This results in smooth running of the gears.
2. It involves double curve for the teeth, epicycloid & hypocycloid. This complicates the manufacture.	2. It involves single curve for the teeth resulting in simplicity of manufacturing and of tools.
3. Owing to difficulty of manufacture, these are costlier.	3. These are simple to manufacture and thus are cheaper.
4. Exact centre-distance is required to transmit a constant velocity ratio.	4. A little variation in the centre distance does not affect the velocity ratio.
5. Phenomenon of interference does not occur at all.	5. Interference can occur if the condition of minimum number of teeth on a gear is not followed.
6. The teeth have spreading flanks and thus are stronger.	6. The teeth have radial flanks and thus are weaker as compared to the cycloidal form for the same pitch.
7. In this, a convex flank always has contact with a concave face resulting in less wear.	7. Two convex surfaces are in contact and thus there is more wear.

(ii)

Given : $T_s = 18$; $T_p = 24$; $T_c = 12^\circ$; $T_A = 72$; $N_s = 840 \text{ rpm}$; $\eta = 95\%$; $P = 6 \text{ kW}$

Action	arm(a)	s	P/C	A
(i) Arm a is fixed, S is given $+x$ rev	0	$+x$	$-x \times \frac{18}{24}$	$-x \times \frac{18}{24} \times \frac{12}{72}$
(ii) arm a is given y rev	y	$x + y$	$y - \frac{3x}{4}$	$y - \frac{x}{8}$

Annular gear A is fixed, $N_A = 0$

$$\Rightarrow y - \frac{x}{8} = 0$$

$$\Rightarrow y = \frac{x}{8} \quad \dots(i)$$

$$N_s = y + x = \frac{x}{8} + x = 840$$

$$\Rightarrow \frac{9x}{8} = 840$$

$$\Rightarrow x = 746.67 \text{ rpm}$$

$$y = \frac{x}{8} = \frac{746.67}{8} = 93.334 \text{ rpm}$$

$$N_a = y = 93.334 \text{ rpm}$$

Ans

By power balance, $T_i \times N_i \times \eta + T_0 \times N_0 = 0$

$$\text{Input torque, } T_i = \frac{P \times 10^3 \times 60}{2\pi N_i} = \frac{6 \times 10^3 \times 60}{2\pi \times 840} = 68.21 \text{ Nm}$$

$$\Rightarrow 68.21 \times 840 \times 0.95 + T_0 \times 93.334 = 0$$

$$T_0 = -583.19 \text{ Nm}$$

$$\Sigma T = 0$$

$$\Rightarrow T_i + T_0 + T_{\text{fixing}} = 0$$

$$\Rightarrow 68.21 - 583.19 + T_{\text{fixing}} = 0$$

$$\Rightarrow T_{\text{fixing}} = 514.98 \text{ Nm}$$

Ans.

$$\text{Now, } N_A = y - \frac{x}{8} = 100 \quad \dots(ii)$$

$$N_s = y + x = 840 \quad \dots(iii)$$

Solving equation (ii) and (iii), we get

$$y = 182.22 \text{ rpm}$$

$$\text{and } x = 657.78 \text{ rpm}$$

$$\therefore \text{New speed of arm } a = y = 182.22 \text{ rpm}$$

Ans.

Section : B

5. (a)

Refer to figure,

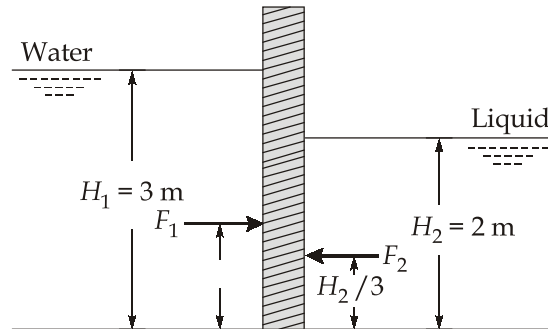

Total pressure on left side of the gate,

$$F_1 = \rho g A \bar{h}_1$$

$$F_1 = 10^3 \times 9.81 \times (3 \times 3) \times \frac{3}{2} = 132.435 \text{ kN}$$

This force acts at a distance of $y_1 = \frac{H_1}{3}$ i.e. $y_1 = \frac{3}{3} = 1$ m from the bottom.

Similarly, total pressure on right side of gate,

$$F_2 = \rho g A \bar{h}_2$$

$$= 10^3 \times 0.85 \times 9.81 \times (3 \times 2) \times \frac{2}{2} = 50.031 \text{ kN}$$

and

$$y_2 = \frac{H_2}{3} = \frac{2}{3} = 0.667 \text{ m}$$

$$\text{Resultant force, } F = F_1 - F_2 = 132.435 - 50.031$$

$$= 82.404 \text{ kN}$$

Ans.

Let the resultant pressure force at a distance y from the bottom. Then taking moments about the bottom.

$$F \times y = F_1 y_1 - F_2 y_2$$

$$82.404 \times y = 132.435 \times 1 - 50.031 \times 0.667$$

 \therefore

$$y = 1.2022 \text{ m}$$

The resultant force acts at a distance of 1.2022 m from the bottom.

5. (b)

At the time of start, the fluid velocities are zero and accordingly the head due to change of kinetic energy or relative velocity is not available. Hence, the centrifugal or pressure

head caused by the centrifugal force on the rotating water will be $\frac{(u_2^2 - u_1^2)}{2g}$.

Pumping action would start, i.e. flow of liquid will commence when the speed of pump is such that the centrifugal head $\frac{(u_2^2 - u_1^2)}{2g}$ is sufficient to counter balance the manometric head (total external head) H_m against which the pump has to work. The pump starting condition is then governed by

$$\frac{(u_2^2 - u_1^2)}{2g} \geq H_m \quad \dots(i)$$

It may be recalled that:

$$H_m = (h_s + h_d) + (h_{fs} + h_{fd}) + \frac{V_d^2}{2g}$$

In the absence of flow, $V_d = 0$ and if there are no friction losses in the suction and discharge pipes, the manometric head then equals the static head, i.e.

$$H_m = h_s + h_d$$

The manometric (hydraulic) efficiency η_m represents the ratio of manometric head H_m available from the pump and the Euler head H_e actually imparted by the impeller to the liquid $\left(\eta_m = \frac{H_m}{H_e}\right)$. Then for determining the minimum starting speed required for pump to commence flow, equation (i) may be written as

$$\frac{u_2^2 - u_1^2}{2g} = \eta_m H_e = \eta_m \frac{V_{u_2} u_2}{g} \quad \dots(ii)$$

or
$$\left(\frac{\pi D_2 N}{60}\right)^2 - \left(\frac{\pi D_1 N}{60}\right)^2 = 2g H_e \times \eta_m$$

or
$$\left(\frac{\pi N}{60}\right)^2 (D_2^2 - D_1^2) = 2g H_e \times \eta_m$$

As given, $D_1 = 0.5D_2$ and $\eta_m = 0.75$

$$\left(\frac{\pi N}{60}\right)^2 \times 0.75 D_2^2 = 14.715 H_e$$

$\therefore D_2 = \left[\frac{14.715 H_e \times 60^2}{\pi^2 N^2 \times 0.75} \right]^{1/2}$

$$= \frac{84.6\sqrt{H_e}}{N} \quad \dots(iii)$$

The above expression represents minimum outer diameter of the impeller to enable the pump to start delivery of liquid at its normal rotational speed.

5. (c)

Lambert’s Cosine Law : Lambert states that for a diffuse radiating surface the total emissive power, E_θ in any direction is directly proportionate to cosine of the angle of emission of radiation θ . That is

$$E_\theta \propto \cos\theta$$

or $E_\theta = C \cos\theta$, where C is a constant ... (i)

To understand this law clearly, consider a hemisphere as shown in figure.

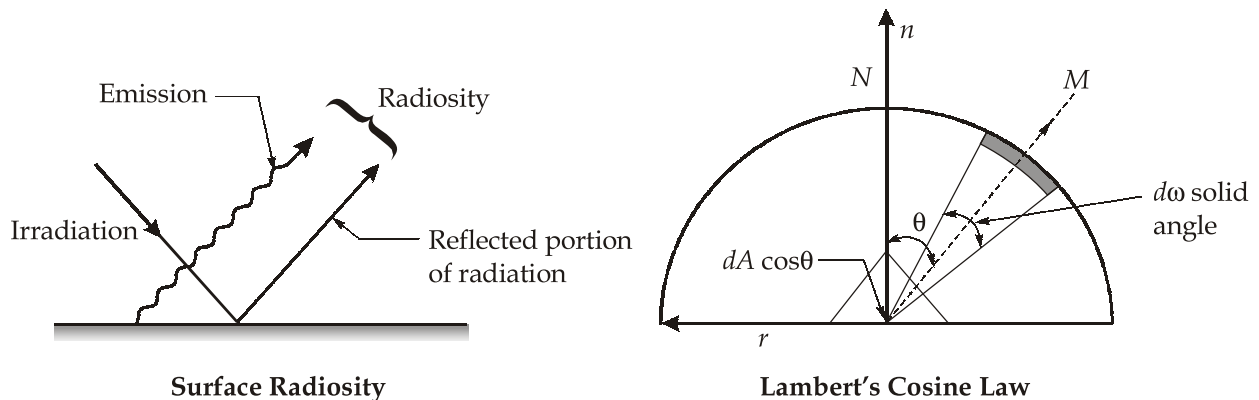

Let an element of a diffused radiating surface be placed at the centre and marked as dA . The rate of energy radiated by dA in the direction of OM is proportional to the cosine of the angle θ between OM and ON , the normal to dA , because M as eye point, a surface ($dA \cos\theta$) is seen which is at equal space distribution of known appears as bright as the area (dA) seen from N . This is known as Lambert’s cosine law.

Let E_n be total emissive power in the normal direction, then

$$\frac{E_\theta}{E_N} = \frac{\cos\theta}{\cos 0^\circ} = \cos\theta$$

Note that the above equation is true only for diffuse radiation surface. A true diffuse radiating surface is one which does not reflects incident radiation as a mirror reflects light but from which the reflected radiation waves are dispersed equally in all directions. Diffuse radiation is not possible from perfectly smooth surfaces but it is possible from most practical surfaces containing a large number of small irregularities.

It is possible to prove that the intensity of radiation I_∞ in any direction is the same for surfaces which obey the Lambert's cosine law. That is

$$I_\infty = I_n = \text{constant}$$

Proof : In order to prove the above result consider the rate of emission of radiation by a surface dA in the normal direction.

$$\therefore \text{Rate of emission} = dA \cdot E_n$$

Now, suppose that this radiation is contained within a solid angle $d\omega$, then rate of emission $= I_n(dA \cos\theta) d\omega$. Since both rate of emission is the same, hence

$$dAE_n = I_n dA d\omega \quad \dots(\text{ii})$$

Again, consider the rate of emission of radiation from dA in direction of θ .

$$\therefore \text{Rate of emission} = dAE_\theta$$

If this radiation is contained within a solid angle $d\omega$, then

$$\text{Rate of emission} = I_\theta (dA \cos\theta) d\omega$$

$$\therefore dA \cdot E_\theta = I_\theta (dA \cos\theta) d\omega \quad \dots(\text{iii})$$

$$\text{or} \quad E_\theta = I_\theta d\omega$$

From equation (ii) and (iii), we get

$$\frac{E_\theta}{E_n} = \frac{I_\theta \cos\theta}{I_n}$$

$$\text{But} \quad E_\theta = E_n \cos\theta, \text{ hence}$$

$$\frac{E_n \cos\theta}{E_n} = \frac{I_\theta \cos\theta}{I_n}$$

$$\text{or} \quad I_\theta = I_n \quad \text{Proved}$$

5. (d)

Construction and working : The vortex tube is a simple device for producing cold and warm air simultaneously.

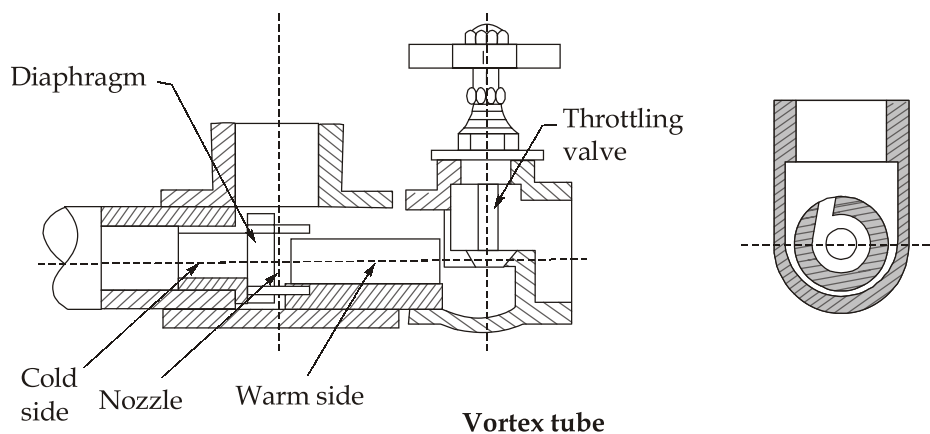

Figure shows the cross-section of a vortex tube that consists of the following parts:

1. Nozzle
2. Diaphragm
3. Cold air side
4. Hot air side
5. Throttling valve

At room temperature and about 5 bar is passed through the nozzle (which is located between warm and cold ends). After expansion through the nozzle it (air) flows tangentially into the vortex chamber. The diaphragm forces the vortex to deviate towards the warm side. When the throttle valve is adjusted let only a fraction of the air leave at warm side, it is found that two streams of air emerge, one at the warm end and another at cold end. The warm side temperature is higher than that of air at inlet and cold side temperature lower. By controlling the opening of valve, the quantity of cold and its temperature can be varied.

Coefficient of Performance (COP) of Vortex Tube

The COP of the vortex tube is defined as the ratio of the cooling effect to the work input to the air compressor.

The expression of COP of the vortex tube is given as:

$$\text{COP} = \eta_{isen} \eta_{comp} \left(\frac{p_a}{p_i} \right)^{\frac{\gamma-1}{\gamma}}, \text{ with perfect heat exchanger}$$

where,

η_{isen} = Vortex tube isentropic efficiency

$$= \frac{\text{Actual cooling}}{\text{Ideal cooling}}$$

η_{isen} = Compressor efficiency,

p_i = Pressure of air at inlet to the nozzle, and

p_a = Ambient pressure

If isothermal compression is considered,

$$(\text{COP})_{\text{isothermal}} = \frac{\gamma}{\gamma-1} \eta_{isen} \eta_{comp} \frac{\left[1 - \left(\frac{p_a}{p_i} \right)^{\frac{\gamma-1}{\gamma}} \right]}{\ln \left(\frac{p_i}{p_a} \right)}$$

The general expression for COP is given as,

$$\text{COP} = \frac{m_c c_p \Delta T_c}{\frac{m_i c_p}{\eta_{\text{comp}}} \left[\left(\frac{p_i}{p_a} \right)^\gamma - 1 \right]}$$

where suffices i and c stand for inlet to nozzle, and cold end respectively and $\Delta T_c = T_i - T_c$

5. (e)

$$\begin{aligned} \text{Total weight of the system, } W &= 1250 + \rho g V \\ &= 1250 + 10^3 \times 9.81 \times (2 \times 2.5 \times 3) = 148.4 \text{ kN} \end{aligned}$$

Force required to move the tank,

$$F = \mu W = 0.015 \times 148.4 = 2.226 \text{ kN}$$

This force is provided by the change of momentum

$$\therefore 2.226 \times 10^3 = \rho Q (V_2 - V_1)$$

where V_2 is the velocity of water as it leaves the hole, V_1 is the velocity of main bulk of water in the tank and practically $V_1 = 0$

$$\therefore 2226 = \rho A V_2^2$$

$$\text{or } V_2 = \sqrt{\frac{2226}{10^3 \times 7.5 \times 10^{-4}}} = 54.48 \text{ m/s}$$

To determine air pressure in the tank we employ Bernoulli's equation between the centre line of jet (suffix 2) and the surface of water (suffix 1) in the tank.

$$\frac{P_1}{\rho g} + \frac{V_1^2}{2g} + z_1 = \frac{P_2}{\rho g} + \frac{V_2^2}{2g} + z_2$$

$$\text{or } \frac{P_1}{\rho g} + 0 + 3 = 0 + \frac{54.48^2}{2g} + 0.02$$

$$\text{or } \frac{P_1}{\rho g} = 148.3$$

$$\therefore P_1 = 1454.8 \text{ kPa} \quad \text{Ans.}$$

6. (a)

$$H = 25 \text{ m}; Q = 10 \text{ m}^3/\text{s}; N = 250 \text{ rpm}; \beta_1 = 115^\circ; V_{F_1} = 6.5 \text{ m/s}; V_{w_2} = 0; V_2 = 6 \text{ m/s};$$

$$\eta_H = 0.90\%; \eta_m = 0.95$$

Now, refer to figure,

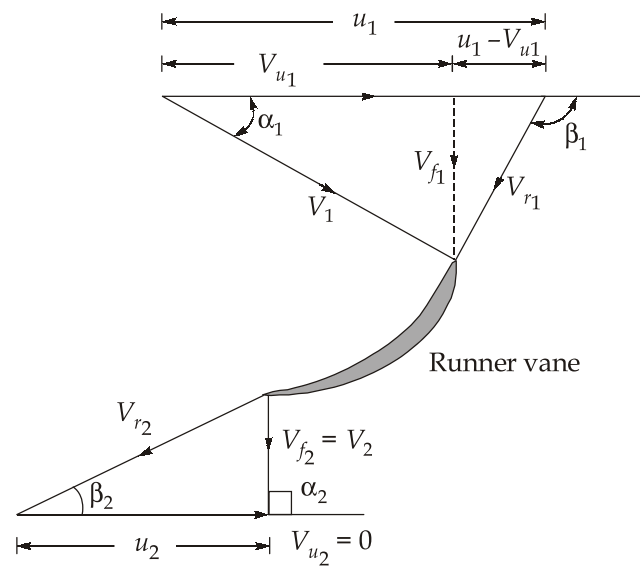

$$u_1 - V_{w1} = \frac{V_{f1}}{\tan(180^\circ - 115^\circ)}$$

$$\therefore u_1 = V_{w1} + \frac{6.5}{\tan 65^\circ} = V_{w1} + 3.03 \quad \dots(i)$$

$$\text{Hydraulic efficiency, } \eta_h = \frac{V_{w1}u_1 + V_{w2}u_2}{gH} \quad (\because V_{w2} = 0)$$

$$\therefore 0.9 = \frac{V_{w1}u_1}{gH}$$

$$\therefore V_{w1}(V_{w1} + 3.03) = 0.9 \times 9.81 \times 25$$

$$\text{or } V_{w1}^2 + 3.03V_{w1} = 220.725$$

On solving, we get

$$V_{w1} = 13.42 \text{ m/s}$$

$$\therefore u_1 = 13.42 + 3.03 = 16.45 \text{ m/s}$$

Also,
$$u_1 = \frac{\pi d_1 N}{60}$$

$$\therefore d_1 = \frac{16.45 \times 60}{\pi \times 250} = 1.257 \text{ m} \quad \text{Ans. (i)}$$

Absolute velocity at entry to runner,

$$V_1 = \sqrt{V_{f1}^2 + V_{w1}^2} = \sqrt{6.5^2 + 13.42^2} = 14.91 \text{ m/s}$$

With datum at the tail race, the total head across the turbine is

$$H = \frac{P_1}{\rho g} + \frac{V_1^2}{2g} + z_1$$

or
$$\frac{P_1}{\rho g} = H - \frac{V_1^2}{2g} - z_1$$

$$\frac{P_1}{\rho g} = 25 - \frac{14.91^2}{2 \times 9.81} - 1.5 = 12.17 \text{ m of water} \quad \text{Ans. (ii)}$$

Considering energy balance at the inlet and outlet of the turbine runner.

$$\frac{P_1}{\rho g} + \frac{V_1^2}{2g} + z_1 = \frac{P_2}{\rho g} + \frac{V_2^2}{2g} + z_2 + H_e + H_L$$

or
$$25 = \frac{P_2}{\rho g} + \frac{6^2}{2g} + 1.2 + 0.9 \times 25 + 0.9$$

$\therefore \frac{P_2}{\rho g} = 25 - 26.435 = -1.435 \text{ m of water} \quad \text{Ans. (ii)}$

Power available at the turbine shaft,

$$P = \rho g Q H \times \eta_0$$

$$P = 10^3 \times 9.81 \times 10 \times 25 \times 0.9 \times 0.95 \\ = 2096.88 \text{ kW}$$

$\therefore N_s = \frac{N\sqrt{P}}{H^{5/4}} = \frac{250\sqrt{2096.88}}{(25)^{5/4}} \\ = 204.78 \quad \text{Ans. (iii)}$

6. (b)

(i)

Nusselt's analysis of film condensation makes the following simplifying assumptions:

1. The film of the liquid formed flows under the action of gravity.
2. The condensate flow is laminar and the fluid properties are constant.
3. The liquid film is in good thermal contact with the cooling surface and, therefore, temperature at the inside of the film is taken equal to the surface temperature t_s .

Further, the temperature at the liquid-vapour interface is equal to the saturation temperature t_{sat} at the prevailing pressure.

4. Viscous shear and gravitational forces are assumed to act on the fluid; thus normal viscous force and inertia forces are neglected.
5. The shear stress at the liquid-vapour interface is negligible. This means there is no

velocity gradient at the liquid-vapour interface $\left[\text{i.e.} \left(\frac{\partial y}{\partial y} \right)_{y=\delta} = 0 \right]$.

6. The heat transfer across the condensate layer is by pure conduction and temperature distribution is linear.
7. The condensing vapour is entirely clean and free from gases, air and non-condensing impurities.
8. Radiation between vapour and liquid film; horizontal component of velocity at any point in the liquid film; and curvature of the film are considered negligibly small.

(ii)

$d = 1.5 \text{ mm}; l = 250 \text{ mm}; V = 20 \text{ V}; I = 45 \text{ A}$

Now, electrical energy input to the wire

$$Q = VI$$

$$Q = 20 \times 45 = 900 \text{ W}$$

Surface area of the wire, $A_s = \pi dl = \pi \times 1.5 \times 10^{-3} \times 0.25$

$$\therefore A_s = 1.178 \times 10^{-3} \text{ m}^2$$

$$\therefore \text{Heat flux, } q = \frac{Q}{A} = \frac{900}{1.178 \times 10^{-3}}$$

$$\therefore q = 764.01 \text{ kW/m}^2$$

Ans.

Using the correlation,

$$1.58(764.01 \times 10^3)^{0.75} = 5.62(\Delta t_e)^3$$

$$\therefore \Delta t_e = (7265.16)^{1/3}$$

$$\therefore \Delta t_e = 19.37^\circ\text{C}$$

Ans.

6. (c)

$t_{db1} = 40^\circ\text{C}; t_{wb1} = 27^\circ\text{C}; t_{db2} = 27^\circ\text{C}; \phi_2 = 50\%; Q_{SH} = 25 \text{ kW}; t_{db4} = 7^\circ\text{C}$

The states and Psychrometric processes shown in figure are discussed below:

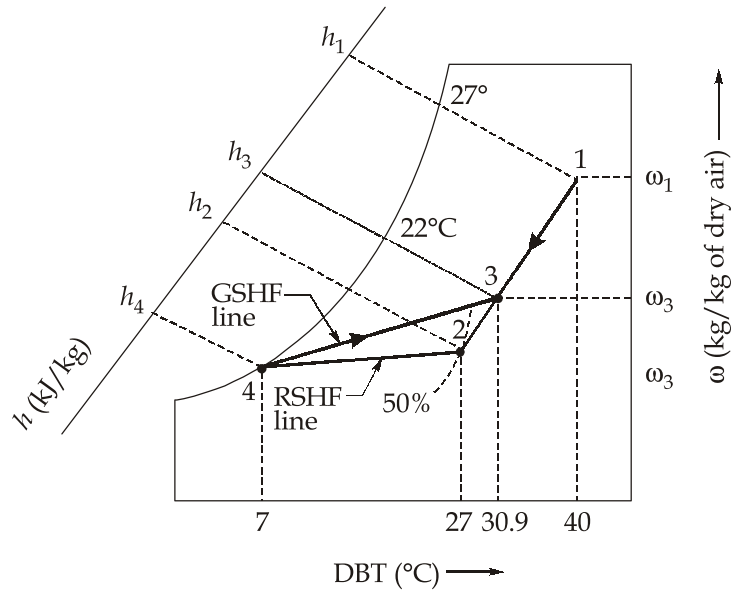

- Locate point 1 at the intersection of 40°C DBT and 27°C WBT.
- Locate point 2 at the intersection of 27°C DBT and 50% RH lines. Join points 1 and 2

Now, $t_{db3} = 0.7 \times 27 + 0.3 \times 40 = 30.9^\circ\text{C}$

From the Psychrometric chart, we find:

$$h_1 = 85.2 \text{ kJ/kg.d.a.; } h_2 = 55.9 \text{ kJ/kg.d.a.}$$

$\therefore h_3 = 0.7 \times 55.9 + 0.3 \times 85.2 = 64.7 \text{ kJ/kg.d.a.}$

Also $h_4 = 22.8 \text{ kJ/kg.d.a.; } \omega_1 = 0.0172 \text{ kg/kg.d.a.}$

$$\omega_2 = 0.0112 \text{ kg/kg.d.a.; } \omega_4 = 0.0062 \text{ kg/kg.d.a.}$$

- Locate point 4 (7°C) on the saturation curve as shown in figure. Join points 3 and 4 and points 2 and 4.

Now, mass of dry air supplied to the space,

$$m_a = \frac{Q_{SH}}{c_{p_m}(t_{db2} - t_{db4})} = \frac{25}{1.022(27 - 7)} = 1.223 \text{ kg/s}$$

\therefore Mass of moist air supplied to space

$$= m_a(1 + \omega_4) = 1.223 \times (1 + 0.0062)$$

$$= 1.2305 \text{ kg/s}$$

Ans.

or

$$= 4429.8 \text{ kg/h}$$

Latent heat gain of space, $Q_{LH} = m_a(\omega_2 - \omega_4) \times 2500$

$$= 1.223(0.0112 - 0.0062) \times 2500$$

$$= 15.2875 \text{ kW}$$

Ans.

$$\begin{aligned}
 \text{Cooling load of air washer, } Q_C &= m_a (h_3 - h_4) \\
 &= 1.223(64.7 - 22.8) \\
 &= 51.24 \text{ kW}
 \end{aligned}$$

Ans.

7. (a)

Given : $d_i = 0.025 \text{ m}$; $d_o = 0.05 \text{ m}$; $\dot{m}_c = 0.2 \text{ kg/s}$; $\dot{m}_h = 0.5 \text{ kg/s}$; $t_{h1} = 90^\circ\text{C}$; $t_{h2} = 60^\circ\text{C}$; $t_{c1} = 25^\circ\text{C}$

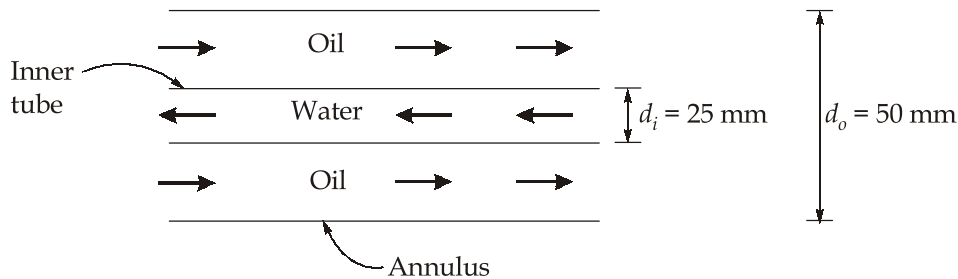

Now,

$$Q = \dot{m}_h c_{ph} (t_{h1} - t_{h2}) = \dot{m}_c c_{pc} (t_{c2} - t_{c1})$$

or

$$0.5 \times 2120(90 - 60) = 0.2 \times 4180 \times (t_{c2} - 25)$$

∴

$$t_{c2} = 63.04^\circ\text{C}$$

LMTD is given by,

$$\theta_m = \frac{\theta_1 - \theta_2}{\ln\left(\frac{\theta_1}{\theta_2}\right)}$$

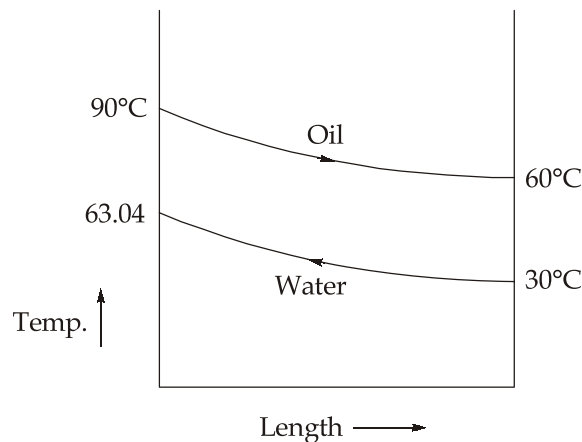

where, $\theta_1 = 90 - 63.04 = 26.96^\circ\text{C}$; $\theta_2 = 60 - 30 = 30^\circ\text{C}$

$$\therefore \theta_m = \frac{26.96 - 30}{\ln\left(\frac{26.96}{30}\right)} = 28.45^\circ\text{C}$$

Reynolds number for flow of water through the tube is

$$\text{Re} = \frac{4\dot{m}_c}{\pi d \mu} = \frac{4 \times 0.2}{\pi \times 0.025 \times 725 \times 10^{-6}} = 14049.54$$

Since the flow is turbulent, $\text{Nu} = \frac{h_i d_i}{k} = 0.023 \times \text{Re}^{0.8} \times \text{Pr}^{0.4}$

$$\therefore \frac{h_i \times 0.025}{0.625} = 0.023 \times (14049.54)^{0.8} \times (4.85)^{0.4}$$

$$\therefore h_i = 2249.54 \text{ W/m}^2\text{K}$$

For annulus,

$$D_h = d_o - d_i = 0.05 - 0.025 = 0.025 \text{ m}$$

$$\therefore \text{Re} = \frac{4\dot{m}_h}{\pi(d_o + d_i) \cdot \mu} = \frac{4 \times 0.5}{\pi \times (0.05 + 0.025) \times 0.0325}$$

$$\therefore \text{Re} = 261.18$$

Since $\text{Re} < 2300$, hence the flow of oil is laminar in the annular portion of tube.

$$\therefore \text{Nu} = \frac{h_o D_h}{k} = 3.66$$

$$\text{or } h_o = \frac{3.66 \times 0.14}{0.025} = 20.496 \text{ W/m}^2\text{K}$$

\therefore Overall heat transfer coefficient,

$$\frac{1}{U} = \frac{1}{h_i} + \frac{1}{h_o}$$

$$U = \frac{2249.54 \times 20.496}{2249.54 + 20.496} = 20.31 \text{ W/m}^2\text{K}$$

Ans.

Also,

$$Q = \dot{m}_h c_{p_h} (t_{h_1} - t_{h_2}) = UAQ_m$$

$$0.5 \times 2120 \times (90 - 60) = 20.31 \times (\pi \times 0.025 \times L) \times 28.45$$

$$\therefore L = 700.72 \text{ m}$$

Ans.

7. (b)

Given : $t_{db_1} = 12^\circ\text{C}$; $\phi_1 = 70\%$; $t_{db_4} = 36.5^\circ\text{C}$; $t_{wb_4} = 21^\circ\text{C}$

- Locate point 1 at the intersection of 12°C DBT and 70% RH lines.
- Locate point 4 at the intersection of 36.5°C DBT and 21°C WBT lines.

- From point 1 draw a horizontal line to represent sensible heating and from point 4 draw horizontal line to intersect 70% RH curve at point 3. Now from point 3, draw a constant WBT line which intersects the horizontal line drawn through point 1 at point 2. The line 1-2 represents preheating of air, line 2-3 represents humidification and line 3-4 represents reheating to final condition.

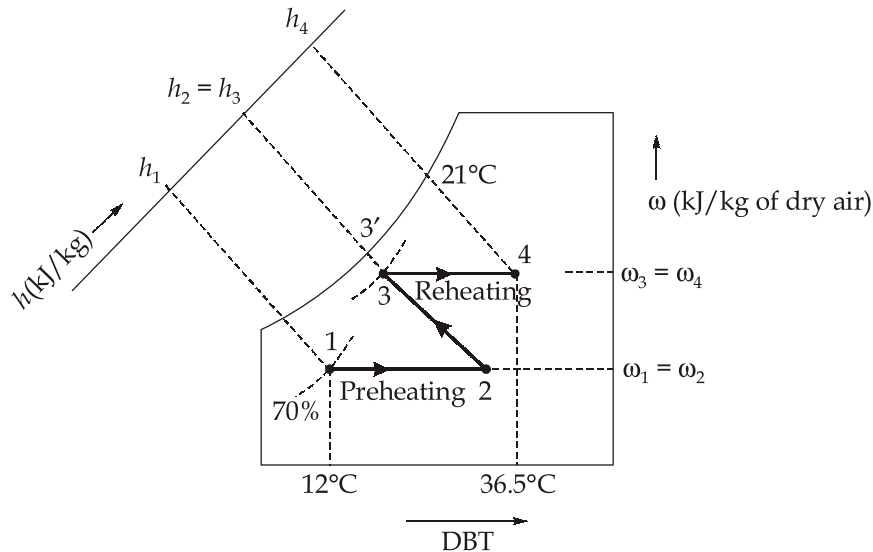

From Psychrometric chart:

$$t_{db2} = 26.6^\circ\text{C} \quad \text{Ans.}$$

$$h_1 = 26.9 \text{ kJ/kg.d.a.}; h_2 = h_3 = 42.3 \text{ kJ/kg.d.a. and}$$

$$h_4 = 61 \text{ kJ/kg.d.a.}; \omega_1 = \omega_2 = 0.006 \text{ kg/kg.d.a.};$$

$$\omega_4 = \omega_3 = 0.0092 \text{ kg/kg.d.a.}$$

$$\text{Total heat required, } Q_T = (h_2 - h_1) + (h_4 - h_3)$$

$$= h_4 - h_1 = 61 - 26.9 = 34.1 \text{ kJ/kg.d.a.} \quad \text{Ans.}$$

Make up water required in the air washer,

$$= (\omega_3 - \omega_2) = (\omega_4 - \omega_1) = 0.0092 - 0.006$$

$$= 0.0032 \text{ kg/kg.d.a.} \quad \text{Ans.}$$

From Psychrometric chart, $t_{db3} = 18.5^\circ\text{C}; t_{db3'} = 15^\circ\text{C}$

∴ Humidifying efficiency of the air washer,

$$\eta_H = \frac{t_{db2} - t_{db3}}{t_{db2} - t_{db3'}} = \frac{26.6 - 18.5}{26.6 - 15}$$

$$= 0.6983 \text{ or } 69.83\% \quad \text{Ans.}$$

7. (c)

Refer to figure,

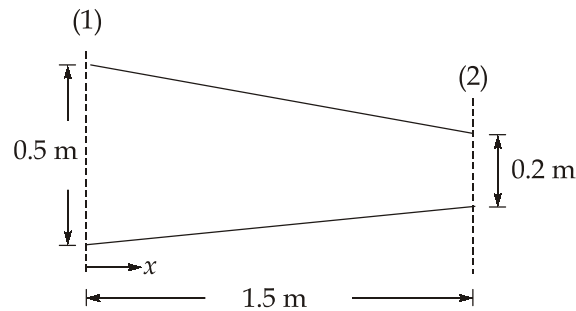
At distance x -metre from the inlet,

$$d_x = 0.5 - \left(\frac{0.5 - 0.2}{1.5} \right) x = 0.5 - 0.2x$$

$$\text{Flow velocity, } u = \frac{Q}{A} = \frac{Q}{(0.5 - 0.2x) \cdot 1} = \frac{Q}{(0.5 - 0.2x)}$$

$$\begin{aligned} \text{Velocity gradient, } \frac{\partial u}{\partial x} &= \frac{\partial}{\partial x} \left(\frac{Q}{0.5 - 0.2x} \right) = \frac{Q \times 0.2}{(0.5 - 0.2x)^2} \\ &= \frac{0.2Q}{(0.5 - 0.2x)^2} \end{aligned}$$

Case (a) : The discharge is constant and the flow is steady

$$\therefore \text{Acceleration, } a_x = u \frac{\partial u}{\partial x} = \frac{Q}{(0.5 - 0.2x)} \times \frac{0.2Q}{(0.5 - 0.2x)^2}$$

$$\text{or } a_x = \frac{0.2Q^2}{(0.5 - 0.2x)^3}$$

At $x = 0.3$

$$a_x|_{x=0.3} = \frac{0.2 \times 0.95^2}{(0.5 - 0.2 \times 0.3)^3} = 2.12 \text{ m/s}^2$$

Ans.

Case (b) : Flow is unsteady and increases,

$$Q = A \cdot u = (0.5 - 0.2x) \times u$$

$$\frac{\partial Q}{\partial t} = \frac{\partial u}{\partial t} (0.5 - 0.2x) = 0.18 \quad (\text{Given})$$

$$\therefore \frac{\partial u}{\partial t} = \frac{0.18}{(0.5 - 0.2x)}$$

At $x = 0.3$

$$\left. \frac{\partial u}{\partial t} \right|_{x=0.3} = \frac{0.18}{0.5 - 0.2 \times 0.3} = 0.409 \text{ m/s}^2$$

Thus for unsteady flow, the total acceleration is :

$$a_T = 2.12 + 0.409 = 2.53 \text{ m/s}^2$$

Ans.

8. (a)

Refer figure for nomenclature and velocity vector diagrams.

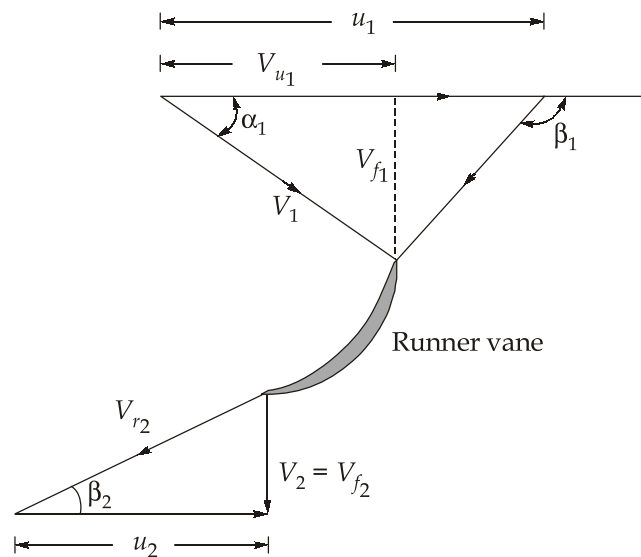

$$P = 25000 \text{ kW}; H = 25 \text{ m}; N = 160 \text{ rpm}; \eta_h = 0.92; \eta_o = 0.88; D_o = 5 \text{ m}; D_b = 2 \text{ m}$$

Now,

$$P = \rho g Q H \times h_o$$

$$\therefore Q = \frac{25 \times 10^6}{10^3 \times 9.81 \times 25 \times 0.88}$$

$$\therefore Q = 115.84 \text{ m}^3/\text{s}$$

Also,

$$Q = \frac{\pi}{4} (D_o^2 - D_b^2) \times V_{f1}$$

$$115.84 = \frac{\pi}{4} (5^2 - 2^2) \times V_{f1}$$

$$V_{f1} = 7.02 \text{ m/s}$$

Analysis at hub section :

$$u_1 = \frac{\pi D_b N}{60} = \frac{\pi \times 2 \times 160}{60} = 16.76 \text{ m/s}$$

$$\text{Hydraulic efficiency, } \eta_H = \frac{V_{w_1} u_1}{gH}$$

$$\Rightarrow 0.92 = \frac{V_{w_1} \times 16.76}{9.81 \times 25}$$

$$\therefore V_{w_1} = 13.46 \text{ m/s}$$

$$\tan(180 - \beta_1) = \frac{V_{f_1}}{u_1 - V_{w_1}} = \frac{7.02}{16.76 - 13.46}$$

$$\therefore \beta_1 = 180 - \tan^{-1}\left(\frac{7.02}{16.76 - 13.46}\right) = 180^\circ - 64.82^\circ = 115.18^\circ$$

$$\text{At exit, } \tan\beta_2 = \frac{V_{f_2}}{u_2} = \frac{7.02}{16.76}$$

$$\therefore \beta_2 = 22.73^\circ$$

Analysis at extreme edge of the runner;

$$u_1 = \frac{\pi D_0 N}{60} = u_2$$

$$\therefore u_1 = u_2 = \frac{\pi \times 5 \times 160}{60} = 41.89 \text{ m/s}$$

$$\text{Again, } \eta_h = 0.92 = \frac{V_{w_1} u_1}{gH}$$

$$\therefore V_{w_1} = \frac{0.92 \times 9.81 \times 25}{41.89} = 5.39 \text{ m/s}$$

$$\therefore \tan(180 - \beta_1) = \frac{V_{f_1}}{u_1 - V_{w_1}} = \frac{7.02}{41.89 - 5.39}$$

$$\therefore \beta_1 = 180^\circ - \tan^{-1}\left(\frac{7.02}{41.89 - 5.39}\right) = 180^\circ - 10.89^\circ$$

$$\beta_1 = 169.11^\circ$$

From exit velocity diagram,

$$\tan\beta_2 = \frac{V_{f_2}}{u_2} = \frac{7.02}{41.89}$$

$$\therefore \beta_2 = 9.51^\circ$$

Hence, runner vane angles

At hub : $\beta_1 = 115.18^\circ$ and $\beta_2 = 22.73^\circ$

At outer tip : $\beta_1 = 169.11^\circ$ and $\beta_2 = 9.51^\circ$

8. (b)

Given : $T_1 = 1200$ K; $\epsilon_1 = 0.7$; $T_2 = 300$ K; $\epsilon_2 = 0.6$; $\epsilon_{3h} = 0.1$; $\epsilon_{3c} = 0.3$

Without shield, heat transfer rate is

$$Q = \frac{\sigma(T_1^4 - T_2^4)}{\frac{1}{\epsilon_1} + \frac{1}{\epsilon_2} - 1} = \frac{5.67 \times 10^{-8} \times (1200^4 - 300^4)}{\frac{1}{0.7} + \frac{1}{0.6} - 1}$$

$\therefore Q = 55.895$ kW/m²

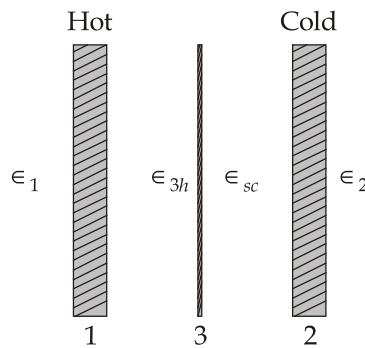

When a radiation shield is kept between two plates, then for thermal equilibrium we can write

$$Q' = \frac{\sigma(T_1^4 - T_3^4)}{\frac{1}{\epsilon_1} + \frac{1}{\epsilon_{3h}} - 1} = \frac{\sigma(T_3^4 - T_2^4)}{\frac{1}{\epsilon_{3c}} + \frac{1}{\epsilon_2} - 1}$$

where T_3 is the temperature of the shield and ϵ_{3h} and ϵ_{3c} are the emissivities of the shield towards hot plate surface and cold plate surface. Substituting the given values, we get

$$\frac{12^4 - x^4}{\frac{1}{0.7} + \frac{1}{0.1} - 1} = \frac{x^4 - 3^4}{\frac{1}{0.6} + \frac{1}{0.3} - 1}, \quad \text{where } x = \frac{T_3}{100}$$

$$\frac{20736 - x^4}{10.428} = \frac{x^4 - 81}{4}$$

or $20736 - x^4 = 2.607x^4 - 211.167$

$\therefore x^4 = \frac{20736 + 211.167}{3.607} = 5807.365$

$$\therefore x = 8.729$$

$$\Rightarrow T_3 = 872.9 \text{ K}$$

The heat flow per m^2 area with shield is

$$Q' = \frac{\sigma(T_1^4 - T_3^4)}{\frac{1}{\epsilon_1} + \frac{1}{\epsilon_{3h}} - 1} = \frac{5.67 \times 10^{-8} (1200^4 - 872.9^4)}{\frac{1}{0.7} + \frac{1}{0.1} - 1}$$

$$\therefore Q' = 8.117 \text{ kW/m}^2$$

\(\therefore\) Percentage reduction in heat flow,

$$= \frac{Q - Q'}{Q} \times 100 = \frac{55.895 - 8.117}{55.895} \times 100$$

$$= 85.48\%$$

Ans.

8. (c)

Given : $D = 0.2 \text{ m}$; $l = 0.5 \text{ m}$; $N = 40 \text{ rpm}$; $h_s = 1 \text{ m}$; $d_s = 0.1 \text{ m}$; $l_s = 2.5 \text{ m}$; $h_d = 35 \text{ m}$;
 $d_d = 0.1 \text{ m}$; $l_d = 40 \text{ m}$; $\theta = 60^\circ$; $f = 0.0075$

$$\text{Crank radius, } r = \frac{0.5}{2} = 0.25 \text{ m}$$

$$\text{Area of plunger, } A_p = \frac{\pi}{4} \times 0.2^2 = 0.0314 \text{ m}^2$$

Area of suction and delivery pipe

$$A_d = A_s = \frac{\pi}{4} \times 0.1^2 = 7.854 \times 10^{-3} \text{ m}^2$$

$$\text{Angular velocity, } \omega = \frac{2\pi N}{60} = \frac{2 \times \pi \times 40}{60} = 4.189 \text{ rad/s}$$

Acceleration head in suction pipe,

$$h_{as} = \frac{l_s}{g} \frac{A_p}{A_s} \omega^2 r \cos \theta$$

$$= \frac{2.5}{9.81} \times \frac{0.0314}{7.854 \times 10^{-3}} \times 4.189^2 \times 0.25 \cos 60^\circ$$

$$h_{as} = 2.235 \text{ m}$$

Frictional head in suction pipe,

$$h_{fs} = \frac{4fl_s}{2gd_s} \left(\frac{A_p}{A_s} \omega r \sin \theta \right)^2$$

$$= \frac{4 \times 0.0075 \times 2.5}{2 \times 9.81 \times 0.1} \left(\frac{0.2^2 \times 4.189 \times 0.25 \times \sin 60^\circ}{0.1^2} \right)^2$$

$$\therefore h_{fs} = 0.503 \text{ m}$$

\therefore Pressure head on the piston on suction side,

$$\begin{aligned} H_s &= H_{\text{atm}} - (h_s + h_{as} + h_{fs}) \\ &= 10.3 - (1 + 2.235 + 0.503) = 6.562 \text{ m (Absolute)} \end{aligned}$$

\therefore Force on the piston from suction side,

$$\begin{aligned} F_s &= \rho g A H_s \\ &= 10^3 \times 9.81 \times 0.0314 \times 6.562 = 2021.32 \text{ N} \end{aligned}$$

Now, corresponding the angular displacement of 60° from the inner dead centre for the suction stroke, the angular displacement from the outer dead centre for the delivery stroke will be

$$\theta = 180^\circ - 60^\circ = 120^\circ$$

Now, acceleration head in delivery pipe,

$$\begin{aligned} h_{ad} &= \frac{l_d}{g} \frac{A_p}{A_d} \omega^2 r \cos \theta \\ &= \frac{40}{9.81} \times \frac{0.0314}{7.854 \times 10^{-3}} \times 4.189^2 \times 0.25 \cos 120^\circ \\ &= -35.757 \text{ m} \end{aligned}$$

Friction head in delivery pipe,

$$\begin{aligned} h_{fd} &= \frac{4 f l d}{2 g d a} \left[\frac{A_p}{A_d} \omega r \sin \theta \right]^2 \\ \therefore h_{fd} &= \frac{4 \times 0.0075 \times 40}{2 \times 9.81 \times 0.1} \left[\frac{0.2^2 \times 4.189 \times 0.25 \sin 120^\circ}{0.1^2} \right]^2 \\ &= 8.05 \text{ m} \end{aligned}$$

\therefore Pressure head on the piston on delivery side,

$$\begin{aligned} H_d &= H_{\text{atm}} + (h_d + h_{fd} + h_{ad}) \\ &= 10.3 + (35 - 35.757 + 8.05) = 17.6 \text{ m (Absolute)} \end{aligned}$$

\therefore Force on the piston from delivery side,

$$\begin{aligned} F_d &= \rho g A H_d = 10^3 \times 9.81 \times 0.0314 \times 17.6 \\ &= 5421.4 \text{ N} \end{aligned}$$

\therefore Net force on the piston, $F = F_d - F_s$

$$\begin{aligned} &= 5421.4 - 2021.32 \\ &= 3400.08 \text{ N} \end{aligned}$$

Ans.

