



GATE 2023

**CIVIL
ENGINEERING**

**Memory based
Questions
& Solutions**



Corporate Office: 44-A/1, Kalu Sarai, New Delhi-110016
MADE EASY Centres : Delhi , Hyderabad , Jaipur, Bhopal,
Lucknow, Bhubaneswar, Pune, Kolkata



9021300500



www.madeeasy.in

**Exam held
on 12th Feb, 2023
Afternoon
Session**

SECTION - A

GENERAL APTITUDE

Reasoning Aptitude

- Q.1 If $4^{8^x} = 256$, then, $x = \underline{\hspace{1cm}}$?
- (a) $\log_{16}8$ (b) $\log_4 8$
(c) $\frac{1}{2}$ (d) $\frac{2}{3}$

Ans. (d)

$$4^{8^x} = 256$$

$$\Rightarrow 4^{8^x} = 4^4$$

$$\Rightarrow 8^x = 4$$

$$\Rightarrow (2^3)^x = 2^2$$

So, $x = \frac{2}{3}$

End of Solution

- Q.2 Three husband-wife pairs are to be seated at a circular table that has six identical chairs. Seating arrangements are defined only by the relative position of the people. How many seating arrangements are possible such that every husband sits next to his wife?
- (a) 720 (b) 120
(c) 4 (d) 16

Ans. (d)

$H_1 W_1, H_2 W_2, H_3 W_3$

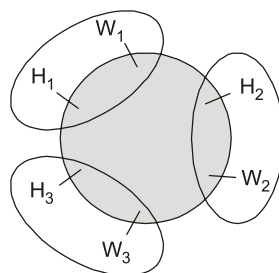

Treat every husband-wife pairs as one block
There are three pair
So all three pair can be arrange by $(3 - 1)!$ ways and in all pair husband and wife can be arranged by $2!$ ways.
So required number of ways are $2! \times 2^3 = 16$

End of Solution

Q.3 One box had 4 red, 5 green and 6 blue balls, N number of balls were asked to take out simultaneously so that it's gives guarantee that atleast 2 balls are of same colour then, minimum no of N.

- (a) 4 (b) 3
(c) 2 (d) 5

Ans. (a)

Given: 4 Red, 5 Green and 6 Blue

We select three balls in worst case

1 Red, 1 Green and 1 Blue

If we select fourth ball then we found two balls are of same colour.

End of Solution

Q.4 In how many ways can cells in a 3×3 grid be shaded such that each column and each row have exactly one shaded cell?

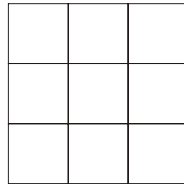

- (a) 3 (b) 6
(c) 2 (d) 9

Ans. (b)

$$\begin{aligned} \text{Possible ways} &= 3 \times 2 \times 1 \\ &= 6 \end{aligned}$$

End of Solution

English

Q.5 Kind : _____ : : Often : Seldom

- (a) Cruel (b) Kindness
(c) Variety (d) Type

Ans. (a)

End of Solution

Q.6 The line ran _____ the page, right through the centre, and divided the page into two

- (a) between (b) about
(c) of (d) across

Ans. (d)

End of Solution



SECTION - B

TECHNICAL

Mathematics

Q.7 Which of the following probability distribution function has the mean greater than the median?

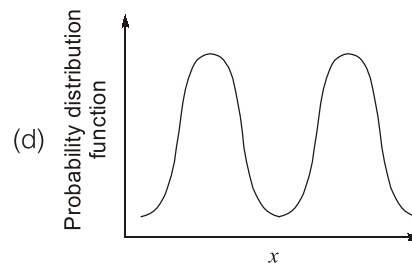
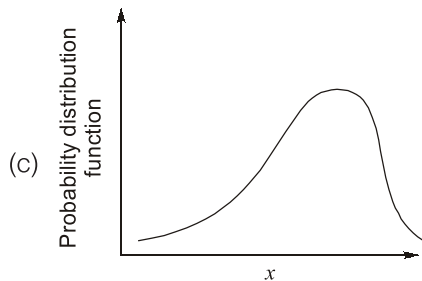
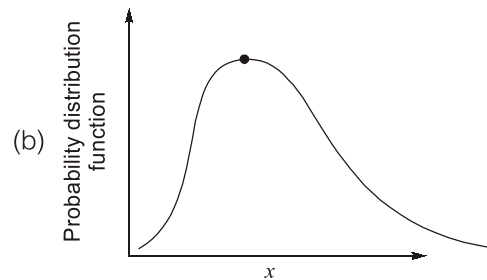
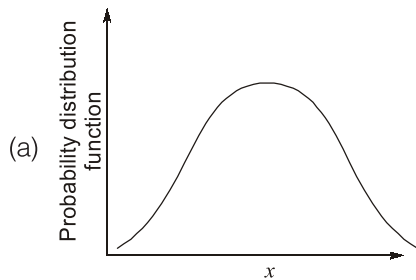

Ans. (b)

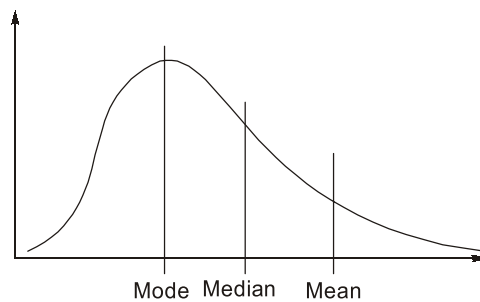

Mode < Median < Mean

End of Solution

Q.8 For the matrix A given by $A = \begin{bmatrix} 1 & -1 & 0 \\ -1 & 2 & -1 \\ 0 & -1 & 1 \end{bmatrix}$. The number of linearly independent eigen vector is _____.

Ans. (3)

As $|A| = 0$

So, one of the eigen value is zero.

$$|A - \lambda I| = 0$$

$$\begin{bmatrix} 1-\lambda & -1 & 0 \\ -1 & 2-\lambda & -1 \\ 0 & -1 & 1-\lambda \end{bmatrix} = 0$$

$$(1-\lambda)[(2-\lambda)(1-\lambda)-1]+1[\lambda-1] = 0$$

$$(1-\lambda)[(2-\lambda)(1-\lambda)-1-1] = 0$$

$$\lambda(1-\lambda)(3-\lambda) = 0$$

$$\lambda = 0, 1, 3$$

As there are three eigen values so number of linearly independent eigen vector are 3.

End of Solution

Q.9 If ϕ is a scalar field and μ is a vector field, then $\text{div}(\phi\vec{\mu})$ is

- (a) $\text{div}(\phi\mu) = \phi \text{grad}(\mu) + \mu \cdot \text{grad}(\phi)$ (b) $\text{div}(\phi\mu) = \text{div}(\mu) + \mu \times \text{grad}(\phi)$
 (c) $\text{div}(\phi\mu) = \phi \text{div}(\mu) + \mu \cdot \text{grad}(\phi)$ (d) $\text{div}(\phi\mu) = \phi \text{grad}(\mu) + \mu \times \text{grad}(\phi)$

Ans. (c)

It is special property of vector, $\text{div}(\phi\mu) = \phi \text{div}(\mu) + \mu \cdot \text{grad}(\phi)$

End of Solution

Q.10 The solution of the differential equation:

$$\left\{ \frac{d^3y}{dx^3} - 5.5 \frac{d^2y}{dx^2} + 9.5 \frac{dy}{dx} - 5y \right\} = 0$$

is given by $y = C_1 e^{m_1 x} + C_2 e^{m_2 x} + C_3 e^{m_3 x}$.

If $m_3 = 2.5$, then m_1 and m_2 is given by

- (a) -2, -3 (b) 2, 3
 (c) 1, 2 (d) -1, -2

Ans. (c)

Auxillary equation is,

$$m^3 - 5.5m^2 + 9.5m - 5 = 0$$

By solving above equation, we get

$$m = 2.5, 1, 2$$

So, m_1 and m_2 are 1 and 2.



NST-2 NATIONAL SCHOLARSHIP TEST 2024

For **ESE, GATE & PSUs 2024**
Offline & Online Long-Term Courses

Register at : www.madeeasy.in

Last Date to Register (Online) : **21st Feb, 2023**

Test Date (Online) : **27th Feb, 2023**

Time Duration 45 Minutes	Total Questions 50 Questions	Total Marks 100 Marks	Negative Marking 0.66 Marks	Streams CE, ME, EE, EC, CS, CH
-----------------------------	---------------------------------	--------------------------	--------------------------------	-----------------------------------

9021300500

nst@madeeasy.in

nst.madeeasy.in

Scan to
Register 

Scholarship applicable on batches commencing between
1st March, 2023 to 31st May, 2023

Delhi Centre : 44 - A/1, Kalu Sarai, Near Hauz Khas Metro Station, New Delhi - 110016 | **Ph** : 9021300500

MADE EASY Centres : Delhi | Hyderabad | Jaipur | Bhopal | Lucknow | Bhubaneswar | Pune | Kolkata | www.madeeasy.in

Q.11 Cholesky Decomposition

$$A = \begin{bmatrix} 8 & -5 \\ -5 & a_{22} \end{bmatrix}$$

L_{22} of matrix $[L] = 1.968$

$a_{22} = ?$

- (a) 1 (b) 7
(c) 5 (d) 9

Ans. (b)

$$LL^T = A$$

$$\begin{bmatrix} L_{11} & 0 \\ L_{21} & L_{22} \end{bmatrix} \begin{bmatrix} L_{11} & L_{21} \\ 0 & L_{22} \end{bmatrix} = \begin{bmatrix} 8 & -5 \\ -5 & a_{22} \end{bmatrix}$$

$$L_{11} = 2\sqrt{2}, L_{21} = -\frac{5}{2\sqrt{2}} \text{ and } L_{21}^2 + L_{22}^2 = a_{22}$$

$$a_{22} = \left(-\frac{5}{2\sqrt{2}}\right)^2 + 1.968 = 6.99 \simeq 7$$

End of Solution

Q.12 For a matrix, $A_{4 \times 4}$ rank of A is 2, $X = [2 \ 1 \ 0 \ 3]^T$; $Y = [1 \ 0 \ 1 \ 2]^T$; $K_1X + K_2Y \neq 0$;

- (a) $[0 \ -2 \ 1 \ -1]^T$ (b) $[1 \ 1 \ -1 \ 1]^T$
(c) $[2 \ 0 \ 1 \ 2]^T$ (d) $[3 \ 1 \ 1 \ 2]^T$

Ans. (b)

$$\rho(A_{2 \times 2}) = 2$$

$$N(A) = 2$$

Eigen vectors of matrix A , $\begin{bmatrix} 2 \\ 1 \\ 0 \\ 3 \end{bmatrix}$ and $\begin{bmatrix} 1 \\ 0 \\ 1 \\ 2 \end{bmatrix}$

As these are linearly independent eigen vectors so remaining eigen vectors must be linearly dependent.

Hence, $X - Y = \begin{bmatrix} 1 \\ 1 \\ -1 \\ 1 \end{bmatrix}$

End of Solution

Highway

- Q.13** Which of the following is equal to the stopping sight distance?
- (a) Braking distance required to stop + distance travelled during the perception reaction time
 - (b) Braking distance required to stop
 - (c) Distance travelled during the perception reaction time
 - (d) Braking distance required to stop = Distance travelled during perception reaction time

Ans. (a)

$$SSD = \underbrace{0.278Vt_R}_{\text{Lag distance}} + \underbrace{\frac{V^2}{254(f \pm s)}}_{\text{Braking distance}}$$

End of Solution

- Q.14** As per IRC guidelines (IRC 86 : 2018), extra widening depends on which of the following parameters?
- (a) Number of lanes
 - (b) Longitudinal gradient
 - (c) Super Elevation
 - (d) Horizontal curve radius

Ans. (a, d)

$$W_E = \frac{nl^2}{2R} + \frac{V}{9.5\sqrt{R}}$$

$$\therefore W_E \propto n$$

$$W_E \propto \frac{1}{R}$$

End of Solution

- Q.15** In Marshall mix design, with increase in Bitumen content, which of the following are correct?
- (a) The air voids increases initially and then decreases
 - (b) The VFB increases monotonically
 - (c) The stability decreases initially and then increases
 - (d) The flow increases monotonically

Ans. (b, d)

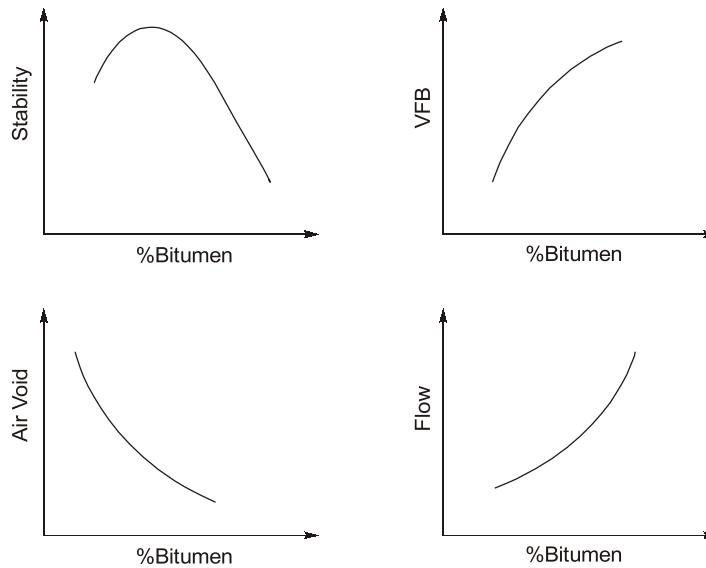

End of Solution

Surveying

Q.16 A ground area of 6 km × 3 km, is drawn as 30 cm × 15 cm on a map. The scale of the photograph is _____?

Ans. (20000)

$$\begin{aligned} (\text{Scale})^2 &= \left(\frac{\text{Area of map}}{\text{Area on ground}} \right) \\ &= \frac{(30 \times 15)}{6 \times 3} = \frac{30 \times 15}{(6 \times 3) \times (100000)^2} \end{aligned}$$

$$\Rightarrow \text{Scale} = \sqrt{\frac{25}{(100000)^2}}$$

$$\therefore S = \frac{1}{20000}$$

End of Solution

Q.17 A delivery agent is at a location R. To deliver the order, she is instructed to travel to location P along the straight line paths of RC, CA, AB and BP of 5 km each. The direction of each path is given in the table below as WCB. Assume that the latitude L and departure D of R as (0, 0) km. What is latitude and departure of P in km?

Path	RC	CA	AB	BP
Direction	120	0	90	240

- (a) L = 0.0, D = 5.0
 (b) L = 0.0, D = 0.0
 (c) L = 2.5, D = 5.0
 (d) L = 5.0, D = 2.5

Ans. (a)

Path (l)	Direction (θ)	Latitude (l cosθ)	Departure (l sinθ)
RC	120°	-2.5	4.33
CA	0°	5	0
AB	90°	0	5
BP	240°	-2.5	-4.33

Length of each path (l) = 5 km

Latitude of P in km = Σlatitude = 0

Departure of P in km = Σdeparture = 5

End of Solution

Q.18 The magnetic bearing of the sun for a location at noon is 183°30'. If the sun is exactly on the geographical meridian at noon, the magnetic declination of the location is _____.

- (a) 93° 30'E
 (b) 3° 30'W
 (c) 3° 30'E
 (d) 93° 30'W

Ans. (b)

$$\begin{aligned} \text{Declination} &= \text{True bearing} - \text{Magnetic bearing} \\ &= 180^\circ - 183^\circ 30' \\ &= -3^\circ 30' = 3^\circ 30' \text{ W} \end{aligned}$$

End of Solution

Strength of Materials

Q.19 Find the reaction at P

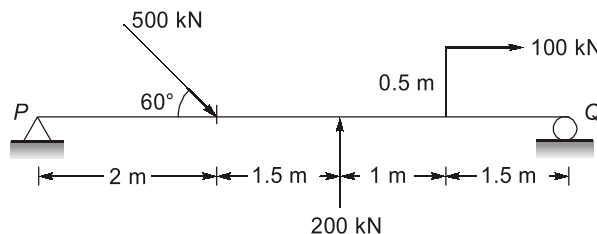



Announcing

FOUNDATION COURSES for **ESE 2024 • GATE 2024**

The Foundation Batches are taught comprehensively which cover the requirements of all technical-syllabus based examinations.

- ✓ Classes by experienced & renowned faculties.
- ✓ Exam oriented learning ecosystem.
- ✓ Systematic subject sequence & timely completion of syllabus.
- ✓ Result oriented teaching with comprehensive coverage.
- ✓ Comprehensive & updated study material.
- ✓ Concept of problems solving through workbooks.
- ✓ Regular performance assessment through class tests.
- ✓ Similar teaching pedagogy in online and offline classes.

OFFLINE BATCHES AT DELHI

Commencing from

- 14th Mar, 2023 • 11th April, 2023
- 4th May, 2023 • 25th May, 2023

LIVE-ONLINE BATCHES

Commencing from

- 15th Feb, 2023 • 14th Mar, 2023
- 15th Apr, 2023 • 15th May, 2023

Admissions open

Delhi Centre : 44 - A/1, Kalu Sarai, Near Hauz Khas Metro Station, New Delhi - 110016 | **Ph :** 9021300500

MADE EASY Centres : Delhi | Hyderabad | Jaipur | Bhopal | Lucknow | Bhubaneswar | Pune | Kolkata | www.madeeasy.in

Ans. (197.01)

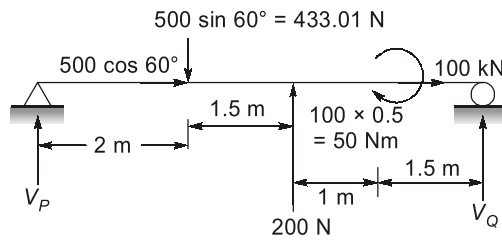

Taking moment at P

$$\Sigma M_P = 0$$

$$\Rightarrow 433.01 \times 2 - 200 \times 3.5 + 50 - V_Q \times 6 = 0$$

$$\Rightarrow V_Q = 36.00 \text{ N}$$

Also, $\Sigma F_y = 0$

$$\Rightarrow V_P + 200 + V_Q = 433.01$$

$$V_P = 433.01 - 200 - 36.00$$

$$V_P = 197.01 \text{ N}$$

End of Solution

Q.20 For the stress element shown below, σ_x and σ_y is given by

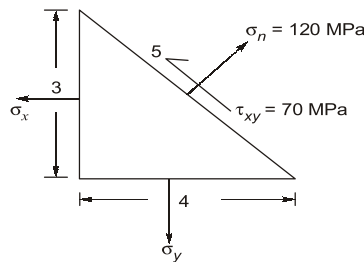

(a) $\sigma_x = 54 \text{ MPa}$, $\sigma_y = 128.5 \text{ MPa}$

(b) $\sigma_x = 26.7 \text{ MPa}$, $\sigma_y = 172.5 \text{ MPa}$

(c) $\sigma_x = 16 \text{ MPa}$, $\sigma_y = 138.5 \text{ MPa}$

(d) $\sigma_x = 67.5 \text{ MPa}$, $\sigma_y = 213.3 \text{ MPa}$

Ans. (d)

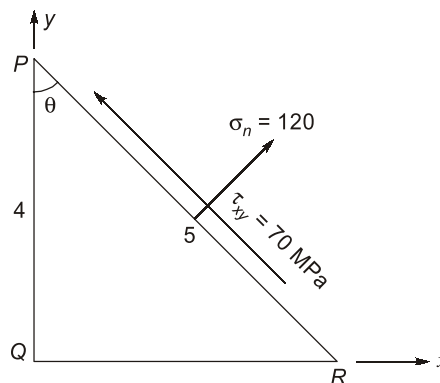

$$\cos\theta = \frac{4}{5} \text{ and } \sin\theta = \frac{3}{5}; \theta = 36.87^\circ$$

\therefore

$$\sigma_n = \sigma_x \cos 2\theta + \sigma_y \sin^2\theta$$

$$\Rightarrow 120 = \sigma_x \times \left(\frac{4}{5}\right)^2 + \sigma_y \left(\frac{3}{5}\right)^2$$

$$25 \times 120 = 16\sigma_x + 9\sigma_y \quad \dots (i)$$

Also,

$$\tau_{xy} = (\theta_y - \theta_x) \sin\theta \cos\theta$$

$$\Rightarrow 70 = (\sigma_y - \sigma_x) \left(\frac{4}{5}\right) \left(\frac{3}{5}\right)$$

$$70 \times 25 = 12\sigma_y + 12\sigma_x \quad \dots (ii)$$

Solving (i) and (ii), $\sigma_x = 67.5 \text{ MPa}$ and $\sigma_y = 213.3 \text{ MPa}$

End of Solution

- Q.21** A circular solid shaft of span $L = 5 \text{ m}$ is fixed at one end and free at the other end. A torsion of 100 kNm is applied at the free end. The shear modulus and polar moment of inertia of the section are denoted as G and J respectively. The torsional rigidity GJ is 50000 kNm^2 . The following are reported for this shaft:
Statement I : The rotation at the free end is 0.01 rad .
Statement II : The torsional strain energy is 1.0 kNm
With reference to the above statements, which of the following is true?
(a) Both statements are wrong
(b) Both statements are correct
(c) Statement I is correct statement II is wrong
(d) Statement I is wrong and statement II is correct

Ans. (c)

Statement 1:

$$\text{Rotation at free end } (\theta) = \frac{\tau L}{GJ} = \frac{100 \times 5 (\text{kNm}^2)}{50000 (\text{kNm}^2/\text{rad})}$$

$$= 0.01 \text{ rad}$$

Statement 2:

$$\text{Torsional strain energy} = \frac{1}{2} \times T \times \theta = \frac{1}{2} \times 100 \times 0.01$$

$$= 0.5 \text{ kN-m}$$

End of Solution

Q.22 An inclined frame supports a load as shown in figure.

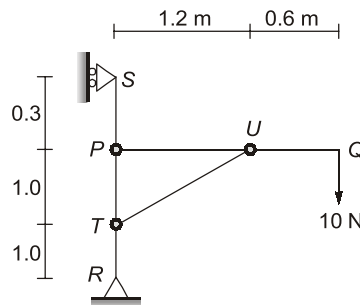

The horizontal component of force transferred from horizontal member PQ to the vertical member RS at P is _____.

Ans. (7.826)

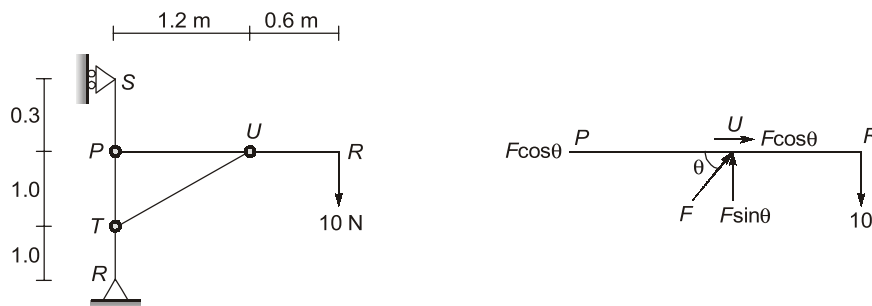

$$\Sigma M_A = 0$$

$$\Rightarrow F \sin \theta \times 1.2 = 10 \times 1.8$$

$$F = \frac{18}{1.2 \sin \theta} = 23.4307$$

Horizontal force at P = 18 N

End of Solution

Geotechnical (Soil)

Q.23 A circular pile of diameter 0.6 m, and length 8 m was constructed in a cohesive soil stratum having the following properties $\gamma_0 = 19 \text{ kN/m}^3$, $\phi = 0^\circ$ and $C = 25 \text{ kPa}$. The allowable load the pile can carry with FOS = 3 is in _____ kN ($\alpha = 1.0$, $N_C = 9.0$)

Ans. (146.87)

$$\begin{aligned} Q_{up} &= 9c \left(\frac{\pi}{4} D^2 \right) + \alpha \bar{c} (\pi DL) \\ &= 9 \times 25 \left(\frac{\pi}{4} \times (0.6)^2 \right) + 1 \times 25 (\pi \times 0.6 \times 8) \end{aligned}$$

$$\therefore Q_{up} = 440.608 \text{ kN}$$

$$\begin{aligned} \therefore \text{Allowable load} &= Q_{ap} = \frac{Q_{up}}{\text{FOS}} = \frac{440.608}{3} \\ &= 146.87 \text{ kN} \end{aligned}$$

End of Solution

Q.24 For an unconfined compressive strength test, if the deviator stress at failure is 76 kPa. Find cohesion of the soil.

Ans. (38)

$$\therefore \sigma_3 = 0 \quad (\text{UCS test})$$

$$\text{So,} \quad \sigma_1 = \sigma_3 \tan^2 \left(45 + \frac{\phi}{2} \right) + 2c \tan \left(45 + \frac{\phi}{2} \right)$$

$$\Rightarrow \quad 76 = 2c \tan \left(45 + \frac{0}{2} \right)$$

$$\Rightarrow \quad c = \frac{76}{2} = 38 \text{ MPa}$$

End of Solution

Q.25 A compound symmetrical open channel section as shown in figure has a maximum of ____ critical depths.

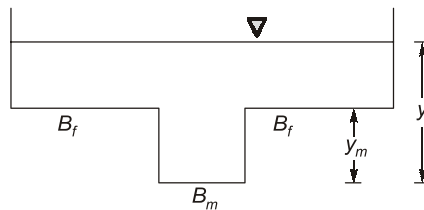

- (a) 2
(c) 4

- (b) 1
(d) 3

Ans. (b)

End of Solution



Conventional Questions Practice Programme for ESE & State Services Exams

Commencing from
1st March, 2023

Teaching Hours :
300 to 350 hours

Course Duration :
100 days

**OFFLINE
& ONLINE
COURSE**

Streams :
CE, ME, EE, EC

Key Features

- ✓ In-depth discussion on conventional questions.
- ✓ Beneficial to develop numerical question-solving techniques.
- ✓ Helps to improve answer writing & presentation skills.
- ✓ Discussion on probable questions.
- ✓ Updated Mains workbook with wide range of practice questions.
- ✓ ESE Mains test series will be conducted on every Sunday in synchronization with the subjects.

Note : Offline classes will be conducted at Delhi Centre.

Delhi Centre : 44 - A/1, Kalu Sarai, Near Hauz Khas Metro Station, New Delhi - 110016 | **Ph :** 9021300500

MADE EASY Centres : Delhi | Hyderabad | Jaipur | Bhopal | Lucknow | Bhubaneswar | Pune | Kolkata | www.madeeasy.in

Q.26 In the given figure point P indicates the stress point of soil element at initial non-hydrostatic stress condition. For the stress path (OP) which of the following coding condition is correct?

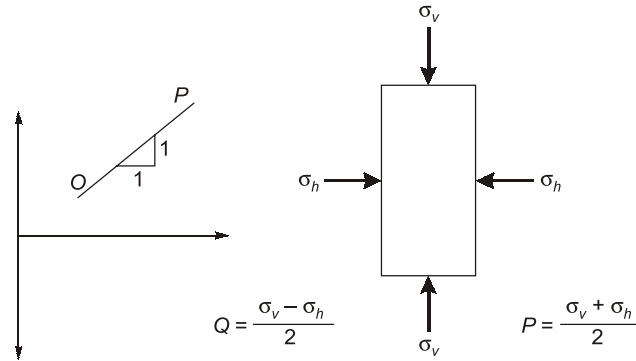

- (a) σ_v is decreasing and σ_h is increasing
- (b) σ_v is increasing and σ_h is decreasing
- (c) σ_v is constant and σ_h is increasing
- (d) σ_v is increasing and σ_h is constant

Ans. (c)

σ_v = Major principal stress

σ_h = Minor principal stress

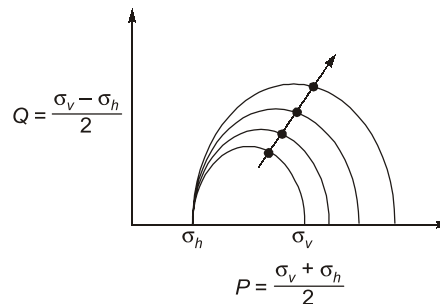

So, σ_h is constant and σ_v is increasing.

End of Solution

Q.27 A vertical sheet pile is installed in an anisotropic soil having coefficient of horizontal permeability, K_H and coefficient of vertical permeability, K_V . In order to draw the flow net for the isotropic condition, embedment depth of the wall should be scaled by a factor of _____ without changing the horizontal scale.

- (a) 1.0
- (b) $\frac{K_H}{K_V}$
- (c) $\sqrt{\frac{K_V}{K_H}}$
- (d) $\sqrt{\frac{K_H}{K_V}}$

Ans. (a)

End of Solution

- Q.28** The reason(s) of the non-uniform elastic settlement profile below a flexible footing, resting on a cohesionless soil subjected to uniform loading.
- Variation of soil stiffness along the depth of footing
 - Variation of friction angle along the depth of the footing.
 - Variation of soil stiffness along the width of the footing.
 - Variation of friction angle along the width of the footing.

Ans. (a, c, d)

The non-uniform elastic settlement profile below a flexible footing resting on cohesionless soil subjected to uniform loading is due to the non-linear behaviour of the soil. When a flexible footing is placed on cohesionless soil, the soil deforms non-linearly due to the soil's low shear strength. This leads to a differential settlement, where the soil settles more near the edges of the footing than in the centre. The non-uniform settlement profile is also influenced by the size and shape of the footing, as well as the intensity and distribution of the applied load. Additionally, the soil's compressibility and deformation characteristics play a crucial role in determining the magnitude and distribution of the settlement. The soil's compressibility, characterized by its compression index, affects the rate of settlement, while its shear strength, characterized by its friction angle, affects the distribution of the settlement.

End of Solution

- Q.29** A square footing is to be designed to carry a column load of 500 kN which is resting on a soil stratum having the following average properties: $\gamma_b = 19 \text{ kN/m}^3$, angle of internal friction, $\phi = 0^\circ$ and $c = 25 \text{ kPa}$. Considering the depth of footing as 1 m and adopting Meyerhoff's bearing capacity theory with a FOS = 3, the width of footing in m is _____.

Ans. (3.48)

As per Meyerhoff's theory,

$$q_u = CN_c s_c d_c i_c + qN_q s_q d_q i_q + 0.5B_r N_r s_r d_r i_r$$

$$\Rightarrow q_u = 5.14 \times 24 + \gamma_{Df}$$

$$\Rightarrow q_{nu} = q_u - \gamma_{Df} = 5.14 \times 24$$

$$\Rightarrow q_{ns} = \frac{q_{nu}}{FOS} = \frac{5.14 \times 24}{3} = 41.12 \text{ kN/m}^2$$

Also, $Q_{ns} = 500 \text{ kN} = q_{ns} \times B^2$

$$\Rightarrow 41.12 \times B^2 = 500$$

$$\Rightarrow B = 3.48 \text{ m}$$

End of Solution

- Q.30** A SPT was carried out at a location by using manually operated hammer dropping system with 50% efficiency, the recorded SPT values at a particular depth is 28, if an automatic hammer dropping system with 70% efficiency is used at the same location, the recorded SPT value will be _____.
- 25
 - 40
 - 28
 - 20

Ans. (d)

$$\text{Efficiency} \propto \frac{1}{\text{Number of blows}} \propto \frac{1}{\text{SPT value}}$$

⇒

$$\eta_1 N_1 = \eta_2 N_2$$

⇒

$$0.5 \times 28 = 0.7 \times N_2$$

⇒

$$N_2 = \frac{0.5 \times 28}{0.7} = 20$$

End of Solution

Q.31 Find the total head at the junction of both the soils. $k_1 = 10 \text{ mm/s}$, $k_2 = 1 \text{ mm/s}$.

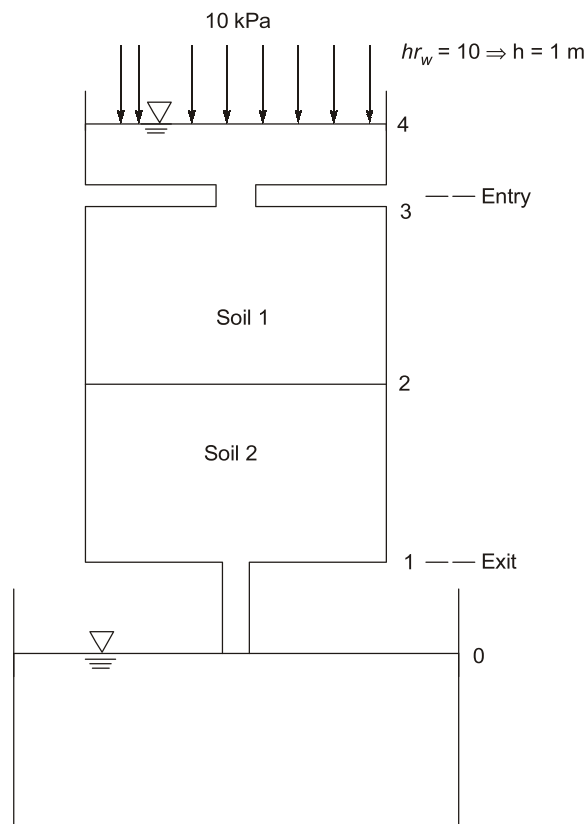

Ans. (4.54)

$$(TH)_{\text{entry}} = D.H + P.H = 3 + 2 = 5 \text{ m}$$

$$(T.H)_2 = (TH)_{\text{entry}} - h_{L1}$$

Now, soil is in series,

$$\text{So, } \frac{\sum z_i}{\sum k_i} \times \left(\frac{H_L}{L} \right)_{\text{Total}} \times A = k_1 \times \frac{h_{L1}}{L_1} \times A$$

$$\Rightarrow \frac{1+1}{\frac{1}{10} + \frac{1}{1}} \times \left(\frac{5}{2} \right) \times A = 10 \times \frac{h_{L1}}{1} \times A$$

$$\Rightarrow h_{L1} = 0.4545$$

$$\therefore (T.H)_2 = 5 - 0.4545 = 4.54 \text{ m}$$

End of Solution

RCC

Q.32 The ultimate moment of resistance, of the beam section is

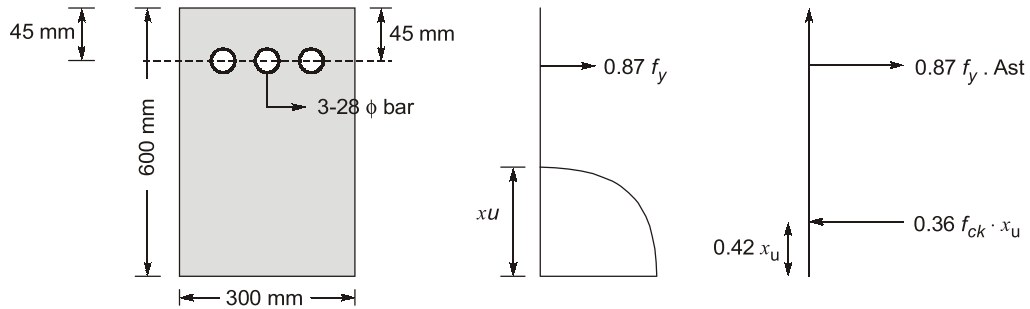

Take M25 concrete and Fe415 steel reinforcement.

Ans. (300)

Given: $B = 300 \text{ mm}$, $d = 600 - 45 = 555 \text{ mm}$

$$\text{Area of steel} = 3 \times \frac{\pi}{4} \times 28^2 = 1847.256 \text{ mm}^2$$

Depth of N.A.:

$$0.36 f_{ck} b x_u = 0.87 f_y A_{st}$$

$$0.36 \times 25 \times 300 \times x_u = 0.87 \times 415 \times 1847.256$$

$$x_u = \frac{0.87 \times 415 \times 1847.256}{0.36 \times 25 \times 300} = 247.02 \text{ mm}$$

$$x_{u,lim} = 0.48d = 0.48 \times 555 = 266.4 \text{ mm} > x_u$$

\therefore Under reinforced section.

$$\begin{aligned} \text{M.R.} &= 0.36 f_{ck} b x_u (d - 0.42 x_u) \\ &= 0.36 \times 25 \times 300 \times 247.02 (555 - 0.42 \times 247.02) \\ &= 300964059.6 \text{ N-mm} \end{aligned}$$

\therefore M.R. = 300.96 kN-m

End of Solution

Q.33 M20 concrete as per IS : 456 : 2000 refer to the concrete with a design mix having.

- An average cylinder strength of 20 MPa.
- A 5 percentile cylindrical strength of 20 MPa.
- A 5 percentile cube strength of 20 MPa.
- An average cube strength of 20 MPa.

Ans. (c)

End of Solution



Rank Improvement Course for **GATE 2024**

Commencing from
1st May, 2023

Teaching Hours :
300 to 350 hours

Course Validity :
Till GATE 2024 Exam

**LIVE-ONLINE
COURSE**

Streams :
CE, ME, EE, EC, CS

Key Features

- ✓ Comprehensive problem-solving sessions by India's top faculties.
- ✓ Focus on improving accuracy & speed.
- ✓ Practice all types of questions to brush up on your concepts.
- ✓ Newly develop workbooks (e-copy) in line with recent trends in GATE.
- ✓ Highly useful for repeaters candidates.

**Download
the App**



Android



iOS

 **9021300500**

 **www.madeeasyprime.com**

Environment

Q.34 For the elevation and temperature data given in the table, the existing lapse rate in the environment is _____ °C/100 m.

Elevation from ground level	Temp (°C)
5 m	14.2
325 m	16.9

Ans. (0.84)

$$\begin{aligned} \text{The existing lapse rate in the environment} &= -\frac{\Delta T}{\Delta H} = -\frac{16.9 - 14.2}{3.25 - 5} \text{ } ^\circ\text{C/m} \\ &= 2.7 \times \frac{100}{320} \text{ } ^\circ\text{C/100 m} \\ &= 0.84 \text{ } ^\circ\text{C/100 m} \end{aligned}$$

End of Solution

Q.35 Which of the following is/are not active disinfectants in water treatment plant?

- (a) Cl^- (b) O_3
(c) OCl^- (d) Hydroxyl radical

Ans. (a)

End of Solution

Q.36 Match the following :

List-I : Air Pollutants

(P) Aromatic Hydrocarbon

(Q) Carbon Monoxide

(R) Sulphur Dioxide

(S) Ozone

List-II : Effect on Health

(I) Reduce the capacity of blood to carry oxygen

(II) Bronchitis and Pulmonary Emphysema

(III) Damages chromosomes

(IV) Carcinogenic effect

Ans. (P-III, Q-I, R-II, S-IV)

End of Solution

Q.37 In the context of water and waste water treatment the correct statements are :

- (a) Ammonia decreases chlorine demand
(b) Phosphorous stimulates algal and adquatic growth.
(c) Ca and Mg increases hardness and TDS
(d) Particulate matter may shield micro-organisms during disinfection.

Ans. (b, c, d)

End of Solution

Q.38 The theoretical aerobic oxidation of bio mass ($C_5H_7O_2N$) is given below :

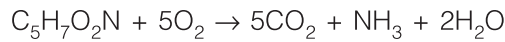

The biochemical oxidation of biomass is assumed as first order reaction with a rate constant is 0.23 day^{-1} at 20°C (base e). Neglecting the second stage oxygen demand from its biochemical oxidation, the ratio of BOD_5 at 20°C to total organic carbon (TOC) is biomass is _____. Atomic weight of C, H, O as 12 g/mol, 1 g/mol, 16 g/mol and for N = 14 g/mol respectively.

Ans. (1.822)



Molar mass of $C_5H_7O_2N = 113\text{g}$

$$TOC = 5 \times 12 = 60\text{g}$$

$$\text{Ultimate BOD} = 5 \times 32 = 160\text{g}$$

$$BOD_5(20^\circ\text{C}) = 160(1 - e^{-0.23 \times 5})$$

$$BOD_5(20^\circ\text{C}) = 109.34\text{g}$$

$$\frac{BOD_5(20^\circ\text{C})}{TOC} = \frac{109.34}{60} = 1.822$$

End of Solution

Q.39 Which of the following statements is/are true for aerobic composting of sewage sludge?

- (a) Bulking agent is added during the composting process to reduce the porosity of the solid mixture.
- (b) In-vessel composting systems cannot be operated in the plug flow mode.
- (c) Antinonocytes are involved in the process.
- (d) Leachate can be generated during composting.

Ans. (c, d)

End of Solution

Fluid Mechanics

Q.40 Which of the following statement(s) is/are correct?

- (a) For curved surface, vertical component of force is equal to the weight of fluid above the surface.
- (b) Momentum correction factor for laminar flow is greater than Momentum correction factor for turbulent flow in pipe flow.
- (c) If the stream line and equipotential line of a source are inter-changed then it will be a sink.
- (d) The thickness of boundary layer in turbulent flow over a flat plate, kept in the direction of flow is directly proportional to square root of the distance from the edge.

Ans. (a, b)

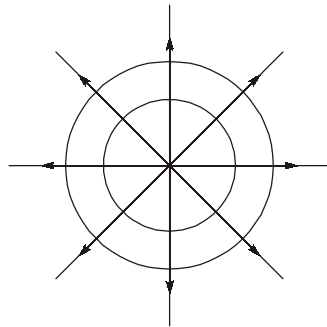

Source

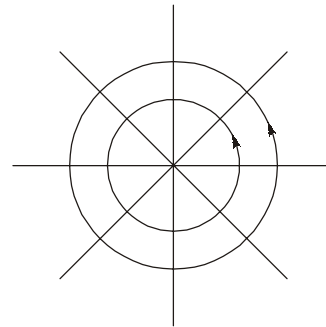

Free-vortex flow

Thickness of boundary layer in turbulent flow:

$$\frac{\delta}{x} = \frac{0.376}{Re_x^{1/5}} = \frac{0.376}{\left(\frac{\rho u_\infty x}{\mu}\right)^{1/5}}$$

$$\Rightarrow \delta = \frac{0.376 x^{4/5}}{\left(\frac{\rho u_\infty}{\mu}\right)^{1/5}}$$

$$\Rightarrow \delta \propto x^{4/5}$$

End of Solution

- Q.41** The pressure in a pipe at X is to be measured by an open manometer as shown in figure. Fluid A is oil with a specific gravity of 0.8 and Fluid B is mercury with a specific gravity of 13.6. The absolute pressure of X is _____ kN/m^2 (rounded off to one decimal place) [Assume density of water as 1000 kg/m^3 and acceleration due to gravity as 9.81 m/s^2 and atmospheric pressure as 101.3 kN/m^2]

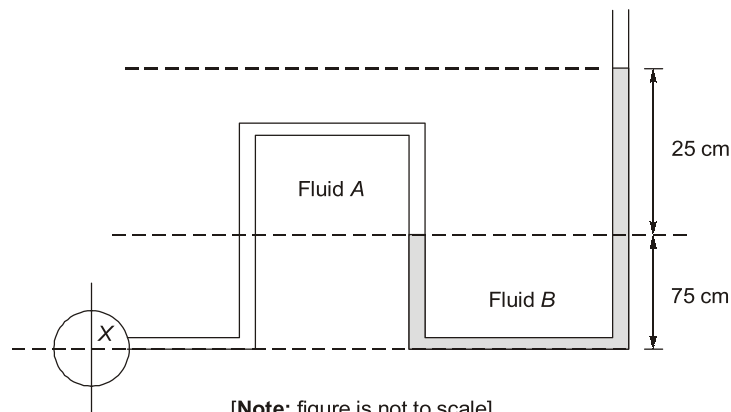

Ans. (140.5)

$$P_x - (800 \times 9.81 \times 0.75) - (13600 \times 9.81 \times 0.25) = P_{\text{atm}}$$

$$P_x = (101.3 \times 10^3) + (800 \times 9.81 \times 0.75) + (13600 \times 9.81 \times 0.25)$$

$$P_x = 140540 \text{ N/m}^2$$

$$P_x = 140.54 \text{ kN/m}^2$$

End of Solution

Steel Structural

Q.42 Two plates are connected by fillet welds of size 10 mm and subjected to tension, as shown in figure. The thickness of each plate is 12 mm. The yield stress and ultimate stress of steel under tension are 250 MPa and 410 MPa respectively. The welding is done in the workshop $\gamma_{mw} = 1.25$. As per limit state method of IS 800 : 2007 what is the minimum length required of each weld to transmit a factored force $P = 275$ kN?

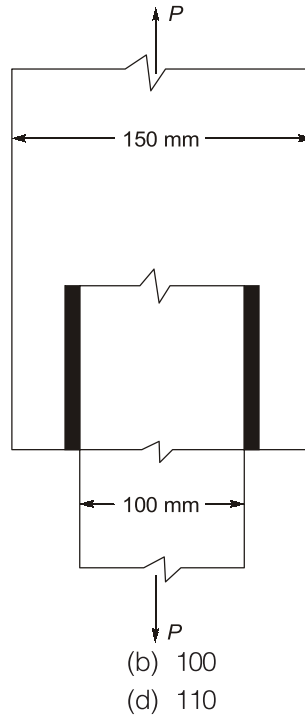

- (a) 115
- (c) 105

- (b) 100
- (d) 110

Ans. (c)

$$P = L_w(ks) \frac{f_u}{\sqrt{3}\gamma_{mw}}$$

$$275 \times 10^3 = L_w \times 0.7 \times 10 \times \frac{410}{\sqrt{3} \times 1.25}$$

$$L_w = 207.45 \text{ mm}$$

$$\text{Length of each weld} = \frac{207.45}{2} = 103.73 \text{ mm} \approx 105 \text{ mm}$$

End of Solution



Live-Online Classes for **SSC-JE 2023**

Batches are live

Validity: **Till 31st July, 2023**

**TECHNICAL &
NON-TECHNICAL
SYLLABUS**

Streams :
CE, ME, EE

Course Details

CE Only Technical	ME Only Technical	EE Only Technical	Non-Tech (RA + GS)
Teaching Hrs : 650 Hrs	Teaching Hrs : 450 Hrs	Teaching Hrs : 300 Hrs	Teaching Hrs : 260 Hrs
Total No. of Books : 16	Total No. of Books : 15	Total No. of Books : 10	Total No. of Books : 03

Key Features

- ✓ Live Classes by experienced and renowned faculties having experience in SSC-JE field.
- ✓ Systematic subject sequence for Paper-I and Paper-II.
- ✓ Comprehensive coverage of Technical & Non-technical syllabus for Prelims & Mains.
- ✓ Well-researched study materials.
- ✓ Facility of watching video thrice, i.e., 1 Live session + 2 Recorded sessions.

📞 **9021300500**

🌐 **www.madeeasyprime.com**

Hydrology

Q.43 Match the column:

Column-I

- (P) Horton's equation
- (Q) Muskingum's equation
- (R) Penmen's equation

Column-II

- (I) Precipitation
- (II) Flood frequency
- (III) Evapotranspiration
- (IV) Infiltration
- (V) Channel Routing
- (b) P-III, Q-I, R-IV
- (d) P-IV, Q-III, R-II

- (a) P-II, Q-IV, R-I
- (c) P-IV, Q-V, R-III

Ans. (c)

End of Solution

Q.44 A circular area of radius 30 km have 5 rain gauges.

Gauge	G ₁	G ₂	G ₃	G ₄	G ₅
Rainfall (mm)	910	930	925	895	905

Using Theissens polygon method, the average rainfall over the catchment is given by

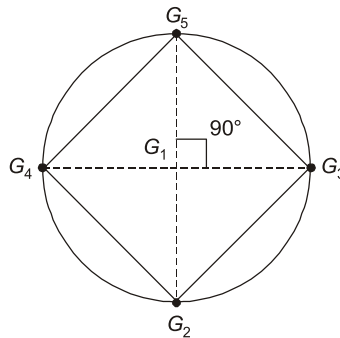

Ans. (912.5)

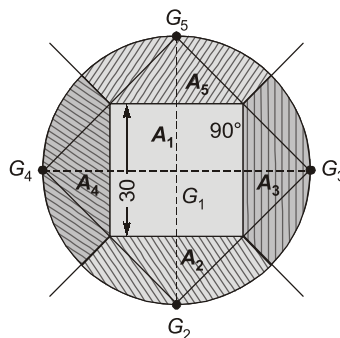

Area of circle (A) = $\pi \times (30)^2$ km²

$A_1 = 30 \times 30 = 900$ km²

$A_2 = A_3 = A_4 = A_5 = \frac{\pi \times 30^2 - 900}{4} = 481.858$ km²

$$\begin{aligned} \therefore \text{Average rainfall, } \bar{P} &= \frac{G_1A_1 + G_2A_2 + G_3A_3 + G_4A_4 + G_5A_5}{A} \\ &= \frac{910 \times 900 + 481.858(930 + 925 + 895 + 905)}{\pi \times 30^2} \\ &= 912.555 \text{ mm} \end{aligned}$$

End of Solution

Irrigation

Q.45 Identify the CD works in the figure:

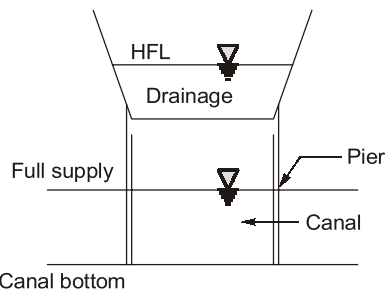

- (a) Super passage (b) Syphon Aqueduct
(c) Level crossing (d) Aqueduct

Ans. (a)

End of Solution

Q.46 The critical flow condition in a channel is given by, α = kinetic energy correction factor.

- (a) $\frac{\alpha Q}{g} = \frac{A_C^3}{T_c^2}$ (b) $\frac{\alpha Q^2}{g} = \frac{A_C^3}{T_c^2}$
(c) $\frac{\alpha Q^2}{g} = \frac{A_C^3}{T_c}$ (d) None of these

Ans. (c)

Froude number, $F_r = \frac{v}{\sqrt{gD}}$; where D = hydraulic depth = $\frac{A}{T}$

$$\Rightarrow F_r^2 = \frac{v^2}{gD}$$

$$\Rightarrow F_r^2 = \frac{Q^2 T}{gA^2 A} = \frac{Q^2 T}{gA^3}$$

For critical condition, $F_r = 1$

$$\Rightarrow \frac{Q^2 T_c}{gA^3} = 1$$

$$\Rightarrow \frac{Q^2}{g} = \frac{A_C^3}{T_c}$$

Now, taking into account, kinetic energy correction factor,

$$\frac{\alpha Q^2}{g} = \frac{A_c^3}{T_c}$$

End of Solution

Structural Analysis

Q.47 For the frame shown in the figure, all members AB, BC, CD, GB and CH have the same length L and flexural rigidity EI . B and C are rigid joints and A and D are fixed supports.

Beam CB and CH carry UDL and the moment of reaction at A is $\frac{wL^2}{k}$. k is ____.

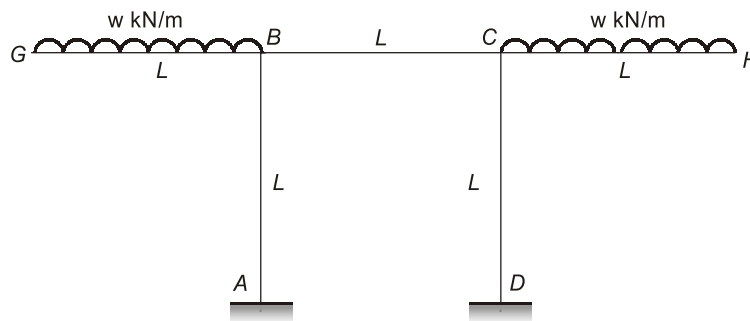

Ans. (6)

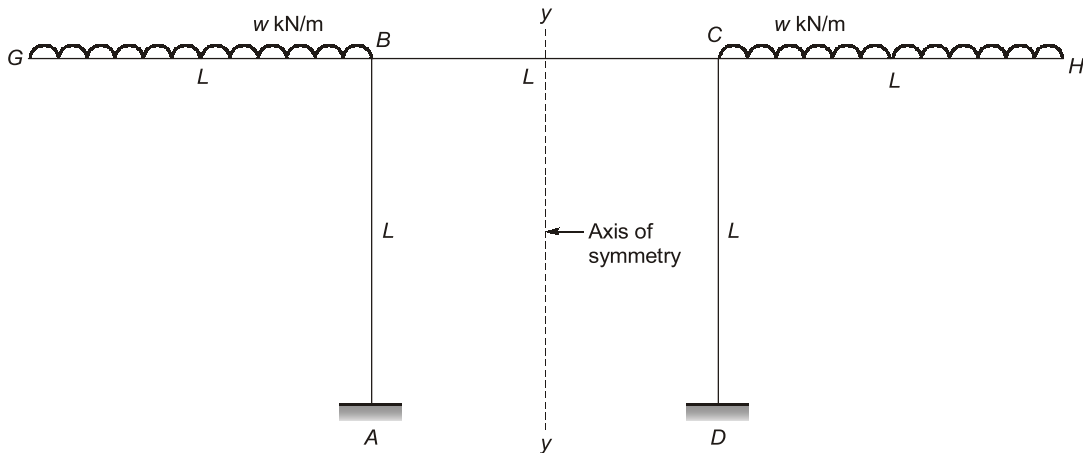

Distribution factors

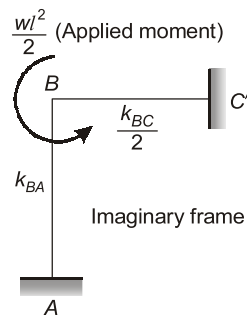

Joint	Member	k	Σk	D.F = $k/\Sigma k$
B	BA	$\frac{1}{L}$	$\frac{3I}{2L}$	$\frac{2}{3}$
	BC'	$\frac{1}{2}(\frac{1}{L})$		$\frac{1}{3}$

End moment distribution

Joint	A	B	C'	
D.F.	0	$\frac{2}{3}$	$\frac{1}{3}$	—
Balance		$-\frac{wl^2}{3}$	$-\frac{wl^2}{6}$	
C.O.M.	$-\frac{wl^2}{6}$			—
Final end moments	$-\frac{wl^2}{6}$	$-\frac{wl^2}{3}$	$-\frac{wl^2}{6}$	—

\therefore Moment at A = $\frac{wl^2}{6}$

$\therefore \alpha = 6$

**Alternatively,
1st method**

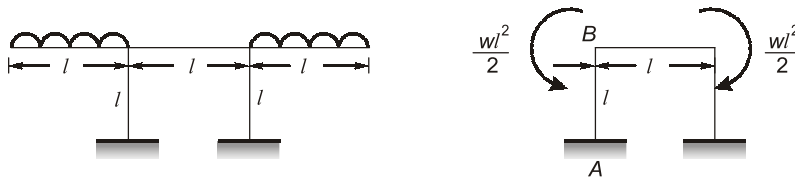

$D_k = 1$ (i.e. θ_3)
 $\theta_c = f(\theta_B)$

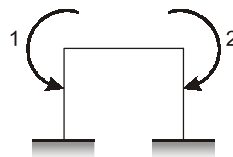

Stiffness matrix

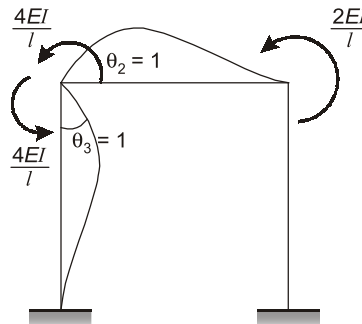

$$[k] = \begin{bmatrix} \frac{8EI}{l} & \frac{2EI}{l} \\ \frac{2EI}{l} & \frac{8EI}{l} \end{bmatrix} = \frac{2EI}{l} \begin{bmatrix} 4 & 1 \\ 1 & 4 \end{bmatrix}$$

Now, $[P] = [P_L] + [k][\Delta]$

$$\Rightarrow 0 = \begin{bmatrix} -wl^2 \\ 2 \\ wl^2 \\ 2 \end{bmatrix} + \frac{2EI}{l} \begin{bmatrix} 4 & 1 \\ 1 & 4 \end{bmatrix} \begin{bmatrix} \theta_B \\ \theta_C \end{bmatrix}$$

$$\frac{wl^2}{2} = \frac{8EI}{l}\theta_B + \frac{2EI}{l}\theta_C$$

$$\frac{wl^2}{2} = \frac{6EI}{l}\theta_B \quad (\because \theta_B = -\theta_C)$$

$$\therefore \theta_B = \frac{wl^2}{12EI}$$

$$\therefore M_{BA} = \frac{4EI}{l}\theta_B = \frac{4EI}{l} \frac{wl^2}{12EI} = \frac{wl^2}{3}$$

$$\therefore M_{BA} = \frac{M_{BA}}{2} = \frac{wl^2}{6}$$

2nd method

Slope deflection method

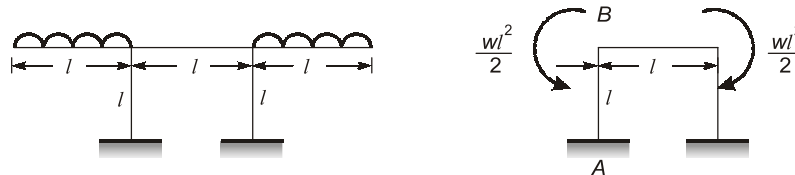

$$M_{BA} = \frac{2EI}{l}(2\theta_B + \theta_A) = \frac{4EI}{l}\theta_B \quad \dots(1)$$

$$M_{BC} = \frac{2EI}{l}(2\theta_B + \theta_C)$$

$$\theta_B = -\theta_C \quad \text{due to symmetry}$$

$$\therefore M_{BC} = \frac{2EI}{l}\theta_B + \frac{4EI}{l}\theta_B$$

Joint equation compliting

$$M_{BA} + M_{BC} = \frac{wl^2}{2}$$

$$\frac{6EI}{l}\theta_B = \frac{wl^2}{2}$$



Live-Online Course for **General Studies** for **State Engineering** and **SSC Exams**

**FULL
FLEDGED
COURSE FOR
GENERAL
STUDIES**

Subject Covered : History, General Science, Polity, Environment, Geography, General Knowledge, Economy & Current Affairs

Duration : 3 Months | **Validity :** 6 Months

Batches commencing from **22nd Feb, 2023**

Key Features

- ✓ 250 Hrs of quality teaching by renowned teachers of MADE EASY.
- ✓ Printed study material will be dispatched to your address.
- ✓ Comprehensive coverage as per latest syllabus and trends of various competitive exams.

$$\Rightarrow \theta_B = \frac{+wl^2}{12EI}$$

$$M_{BA} = \frac{4EI}{l} + \frac{wl^2}{12EI} = \frac{+wl^2}{3EI}$$

$$\therefore M_B = \frac{M_{BA}}{2} = \frac{M_{BA}}{2} = \frac{wl^2}{6EI}$$

End of Solution

Q.48 Muller Breslau's principle is used in analysis of structure for?

- Writing the virtual work expression to get the equilibrium equation.
- Superimposing the load effects to get the total force response in the structure.
- Drawing an ILD for any force response.
- Relating the deflection between two points in a member with the curvature diagram.

Ans. (c)

End of Solution

Q.49 In the frame shown in figure (not to scale) all four members (AB, BC, CD and AD) have the same length and same constant flexural rigidity. All the joints A, B, C and D are rigid. The midpoints of AB, BC, CD, and AD are denoted by E, F, G and H respectively. The frame is in stable equilibrium under the shown forces P acting at E and G. Which of the following statement is/are correct?

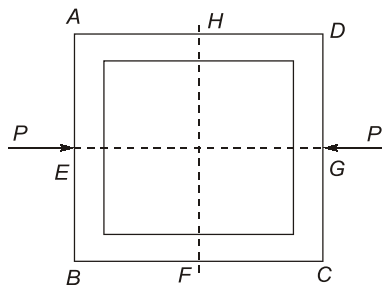

- Slopes at E, F, G, H are zero.
- Vertical displacement H and F are zero
- Shear forces at H and F are zero
- Horizontal displacements at H and F are zero

Ans. (a, c, d)

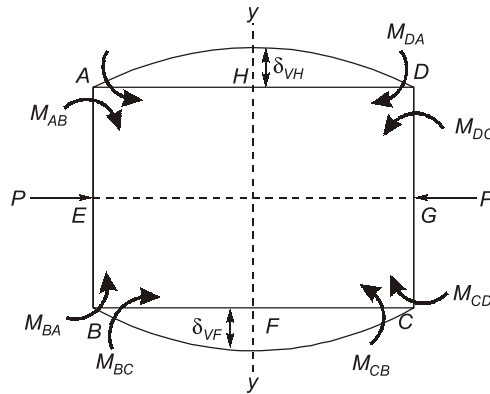

Shear forces at H and F are zero since it is subjected to pure bending.
Horizontal displacements at H and F are zero since axial deformations are neglected.
At the axis of symmetry, slopes must be zero for the deflection profile to be symmetrical.
 \therefore Slopes at E, F, G, H are zero.

End of Solution

