

POSTAL
Study Package

2021

**Production and
Industrial Engineering**

Objective Practice Sets

General Engineering
Volume - III

Machine Design



MADE EASY
Publications

Note: This book contains copyright subject matter to MADE EASY Publications, New Delhi. No part of this book may be reproduced, stored in a retrieval system or transmitted in any form or by any means. Violators are liable to be legally prosecuted.

Machine Design

- Q.1** A single block brake with a torque capacity of 250 Nm is shown in figure. The brake drum rotates at 100 rpm and the friction coefficient is 0.35. The hinge-pin reaction for clockwise rotation of the drum is

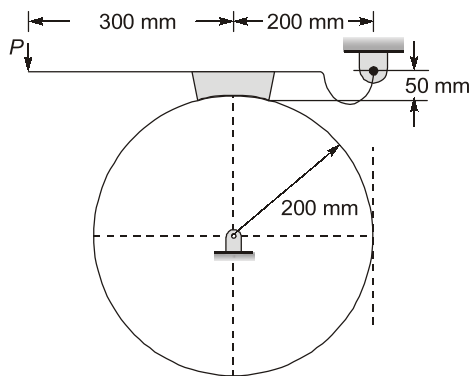

- (a) 2373.66 N (b) 2589.53 N
(c) 3216.82 N (d) 3728.88 N
- Q.2** A compressive force P is applied to a column. The minimum slenderness ratio for which the buckling is considered as the design criteria is _____.
Use: Critical strength for the material = 350 MPa, Young's modulus = 210 GPa.
- Q.3** A solid shaft is subjected to a torque of 22 kNm. What will be the diameter of the shaft if the allowable shear stress is 64 MPa and allowable twist is 1° for 2.2 m length of shaft? Use $G = 98$ GPa
(a) 60 mm (b) 120 mm
(c) 270 mm (d) 130 mm
- Q.4** Which of the following is not type of failure in rivet design?
(a) Shear failure of the rivet.
(b) Shear failure of the plate between two consecutive rivets.
(c) Shear failure of the plate in the margin area.
(d) Tearing of the plate in the margin area.

- Q.5** The longitudinal joint in a boiler shell is usually
(a) butt joint
(b) lap joint
(c) double strap butt joint
(d) single strap butt joint

- Q.6** For an anti friction bearing normal life is 14282 hour at some load, the life of the same bearing at the same load for 40% reliability is
(a) 14282 hour (b) 28162 hour
(c) 48126 hour (d) 54986 hour

- Q.7** Match **List-I** with **List-II** and select the correct answer using the codes given below the lists:

List-I

- A.** Boundary lubricated bearing
B. Ball and roller bearing
C. Hydrostatic lubrication
D. Hydrodynamic lubrication

List-II

1. Thick film lubrication
2. Thin film bearing
3. Antifriction bearing
4. Starting friction is low

Codes:

	A	B	C	D
(a)	2	3	1	4
(b)	3	2	1	4
(c)	2	3	4	1
(d)	3	2	4	1

- Q.8** A disk brake has to be applied on wheel of a motorcycle. Outer diameter of brake pads is 300 mm. Brake pad makes an angle of 80° with the center of rotation of wheels and have an area of 8460 mm^2 . What is the inner diameter of brake pad?
(a) 203.8 mm (b) 201.9 mm
(c) 101.9 mm (d) Insufficient data

- Q.9** An electric motor weighing 10 kN is lifted by means of an eye bolt. The eyebolt is screwed in

to the frame of motor. It is made of plain carbon steel ($S_{yt} = 400 \text{ N/mm}^2$) and factor of safety is 6. The size of bolt is ____ mm.

Q.10 The life of a taper roller bearing at a load of 10 kN is 27000 hr. If the load is increased to 30 kN, keeping all other conditions same, its life is _____ hrs.

Q.11 The standard cross-section for a flat key, which is fitted on a 50 mm diameter shaft, is 16 mm × 10 mm. The key is transmitting 400 Nm torque from the shaft to the hub. The key is made of commercial steel ($S_{yc} = 220 \text{ N/mm}^2$). The length of the key is _____ mm.

Q.12 A circular shaft, 50 mm in diameter, is welded to the support by means of circumferential fillet weld. It is subjected to torsional moment of 2500 N-m. What is the minimum size of the weld, if permissible shear stress in the weld is limited to 140 N/mm^2 ?

- (a) 7 mm (b) 10 mm
(c) 5 mm (d) 14 mm

Q.13 The dynamic load capacity of a ball bearing is 22 kN. The maximum radial load in kN. If it can sustain to operate at 600 rpm, for 2000 hr, is

- (a) 4.16 (b) 3.60
(c) 6.08 (d) 5.29

Q.14 The gears whose diameter is 200 mm rotating with 300 rpm. If tangential load acting on the tooth of gears is 100 N. Service factor is 0.2,

and velocity factor is given by $C_V = \frac{8.5}{5.6 + \sqrt{V}}$.

The effective load between two meshing teeth is _____ N.

Q.15 A conical clutch with angle of cone as 110° supports a load of 20 kN. The external radius is 2.5 times the internal radius. If shaft rotates at 150 rpm. Pressure is 300 kN/m^2 and uniformly distributed coefficient of friction as 0.04. The external diameter of clutch is _____ mm.

Q.16 A steam cylinder has an effective diameter of 300 mm. Cylinder cover is fixed to cylinder by means of bolt. Maximum pressure of steam

is 1.5 MPa. The pitch circle diameter of bolt is 500 mm. The permissible tensile stress in bolt is limited to 30 MPa. What is the circumferential pitch of bolts? Diameter of bolt = 20 mm.

- (a) 130.9 mm (b) 150.5 mm
(c) 120.3 mm (d) 140.63 mm

Q.17 A hollow shaft having outer diameter 100 mm and inner diameter 50 mm. The maximum shear stress is 50 MPa. This shaft is replaced by a solid shaft made of same material which undergoes same torque and same maximum stress. The ratio of weight of hollow shaft to the solid shaft is

- (a) 0.6 (b) 0.5
(c) 0.8 (d) 0.9

Q.18 The permissible stress in a fillet weld is 100 N/mm^2 . The fillet weld has equal leg lengths of 15 mm each. The allowable shearing load on per cm length of the weld is

- (a) 22.5 kN (b) 15.0 kN
(c) 10.6 kN (d) 7.5 kN

Q.19 Two rigid plates are clamped by means of bolt and nut with an initial force N . After tightening, a separating force $P (P < N)$ is applied to the lower plate, which in turn acts on nut. The tension in the bolt after this is

- (a) $(N + P)$ (b) $(N - P)$
(c) P (d) N

Q.20 In the welded joint shown in the given figure if the weld at B has thicker fillets than at A then load carrying capacity P_0 of the joint will

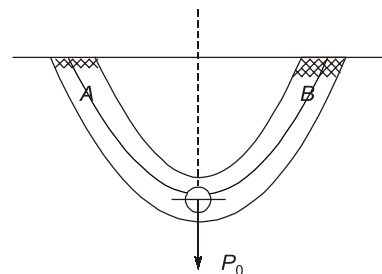

- (a) increase
(b) decrease
(c) remain unaffected
(d) exactly get doubled

Answers Machine Design

1. (b) 2. (76.95) 3. (d) 4. (b) 5. (c) 6. (d) 7. (c) 8. (a)
 9. (17.27) 10. (693.36) 11. (14.54) 12. (a) 13. (d) 14. (576.47) 15. (317.73) 16. (a)
 17. (c) 18. (c) 19. (d) 20. (c) 21. (a) 22. (a) 23. (b) 24. (b)
 25. (b) 26. (d) 27. (b) 28. (c) 29. (d) 30. (c) 31. (b) 32. (a)
 33. (d) 34. (d) 35. (d) 36. (b) 37. (c) 38. (a) 39. (a) 40. (b)
 41. (a) 42. (c) 43. (c) 44. (a) 45. (b) 46. (b) 47. (d) 48. (a)
 49. (a) 50. (d) 51. (d) 52. (b) 53. (a) 54. (a) 55. (b) 56. (a)
 57. (b) 58. (b) 59. (b) 60. (c) 61. (c) 62. (b) 63. (c) 64. (c)
 65. (d) 66. (a) 67. (c) 68. (b) 69. (b) 70. (1839.83) 71. (b) 72. (c)
 73. (b) 74. (512) 75. (a) 76. (b) 77. (b) 78. (c) 79. (b) 80. (30)
 81. (b) 82. (b) 83. (64 Nm) 87. (2.2482) 85. (1098, 40.2) 86. (b) 87. (25)
 88. (d)

Explanations Machine Design

1. (b)

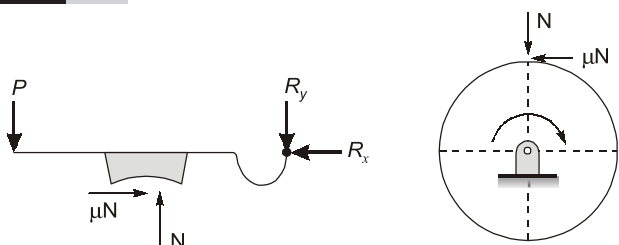

The free body diagram from clockwise rotation of drum is shown above.

Now,
$$N = \frac{M_t}{\mu R} = \frac{250 \times 10^3}{0.35 \times 200}$$

$$= 3571.43 \text{ N}$$

Taking moment about hinge point

$$\mu N(50) + P(500) - N(200) = 0$$

$$\therefore P = 1303.57 \text{ N}$$

Now,

$$R_x = \mu N$$

$$= 0.35 \times 3571.43 = 1250 \text{ N}$$

and,

$$R_y = N - P$$

$$= 3571.43 - 1303.57$$

$$= 2267.86 \text{ N}$$

$$\therefore$$

$$R = \sqrt{R_x^2 + R_y^2}$$

$$27000 = \left(\frac{C}{10}\right)^{10/3}$$

$$L = \left(\frac{C}{30}\right)^{10/3} = 693.36 \text{ hrs.}$$

11. (14.54)

$$M_t = 400 \times 10^3 \text{ N-mm,}$$

$$b = 16 \text{ mm,}$$

$$h = 10 \text{ mm}$$

From the key formula of crushing

$$l = \frac{4M_t}{S_{yc} dh} = \frac{4 \times 400 \times 10^3}{220 \times 50 \times 10}$$

$$= 14.54 \text{ mm}$$

12. (a)

$$\tau = \frac{M_t}{2\pi r^2}$$

$$140 = \frac{2500 \times 1000}{2\pi \times t(25)^2}$$

$$t = 4.55 \text{ mm}$$

$$\text{Size of weld, } h = \frac{t}{0.707} = 6.43 \text{ mm}$$

$$h = 7 \text{ mm}$$

13. (d)

$$C = 22 \text{ kN}$$

$$F_{\text{max radial}} = Pe$$

$$L_{90} = \left[\frac{C}{Pe}\right]^3$$

$$L_{90} = 2000 \times 60 \times 600$$

$$L_{90} = 72 \times 10^6 \text{ revolution}$$

$$72 = \left[\frac{22}{Pe}\right]^3$$

$$Pe = 5.29 \text{ kN}$$

14. (576.47)

$$D = 200 \text{ mm} = 0.2 \text{ m}$$

$$v = \frac{\pi DN}{60} = \frac{\pi \times 0.2 \times 300}{60}$$

$$= 3.14159 \text{ m/sec.}$$

$$C_v = \frac{8.5}{5.6 + \sqrt{3.14159}} = 1.15294$$

$$P_{t \text{ eff}} = \frac{C_s \times P_t}{C_v}$$

But $C_v > 1$, $C_s < 1$

$$P_{t \text{ eff}} = \frac{C_v \times P_t}{C_s}$$

$$P_{t \text{ eff}} = \frac{1.15294 \times 100}{0.2} = 576.47 \text{ N}$$

15. (317.73)

$$F = 20 \text{ kN,}$$

$$R_0 = 2.5 R_i$$

$$P = 300 \text{ kN/m}^2,$$

$$N = 150 \text{ rpm}$$

$$\mu = 0.04,$$

$$\alpha = \frac{110^\circ}{2} = 55^\circ$$

$$\rho = \frac{F}{\pi(R_0^2 - R_i^2)}$$

$$300 \times 10^3 = \frac{20 \times 10^3}{\pi[(2.5R_i)^2 - R_i^2]}$$

$$(2.5R_i)^2 - R_i^2 = \frac{20 \times 10^3}{\pi \times 300 \times 10^3} = 0.0212$$

$$R_i = 0.06354 \text{ m}$$

$$R_0 = 0.15886 \text{ m}$$

$$D_0 = 317.73 \text{ mm}$$

16. (a)

$$D = 300 \text{ mm, } p = 1.5 \text{ MPa}$$

$$F = \text{Force} = P \times \frac{\pi}{4} D^2$$

$$= 1.5 \times \frac{\pi}{4} 300^2 = 106.03 \text{ kN}$$

$$\Rightarrow F_1 = \text{Force by each bolt}$$

$$= \sigma_{\text{per}} \times \frac{\pi}{4} d^2$$

$$\Rightarrow F_1 = 30 \times \frac{\pi}{4} 20^2 = 9.424 \text{ kN}$$

$$\text{Number of bolt} = \frac{F}{F_1} = 11.25 = 12$$

$$\text{circumferential pitch} = \frac{\pi d_p}{12}, d_p = 500 \text{ mm}$$

$$= \frac{\pi \times 500}{12} = 130.9 \text{ mm}$$

17. (c)

$$(\tau_{\text{max}})_H = \frac{16T}{\pi d_2^3 \left(1 - \left(\frac{d_1}{d_2}\right)^4\right)}$$