

# CLASS TEST

S.No. : 03 SP1\_CE\_W+Y\_100819

Steel Structure



## MADE EASY

India's Best Institute for IES, GATE & PSUs

Delhi | Noida | Bhopal | Hyderabad | Jaipur | Lucknow | Indore | Pune | Bhubaneswar | Kolkata | Patna

Web: [www.madeeasy.in](http://www.madeeasy.in) | E-mail: [info@madeeasy.in](mailto:info@madeeasy.in) | Ph: 011-45124612

# CLASS TEST 2019-2020

## CIVIL ENGINEERING

Date of Test : 10/08/2019

### ANSWER KEY > Steel Structure

1. (a)	7. (c)	13. (d)	19. (b)	25. (a)
2. (c)	8. (a)	14. (a)	20. (a)	26. (c)
3. (d)	9. (b)	15. (d)	21. (a)	27. (a)
4. (c)	10. (a)	16. (d)	22. (a)	28. (c)
5. (b)	11. (a)	17. (c)	23. (d)	29. (d)
6. (b)	12. (b)	18. (a)	24. (b)	30. (c)

### Detailed Explanations

3. (d)

The minimum diameter to be provided is greater of  $3t$  or  $25$  mm.

$$D \geq (3t \text{ or } 25 \text{ mm})$$

$$D \geq (18 \text{ mm or } 25 \text{ mm})$$

$$D = 25 \text{ mm}$$

4. (c)

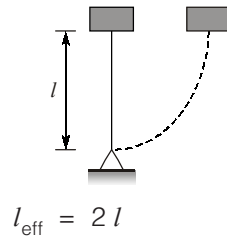

5. (b)

As  $I_{yy}$  of combination is less than  $I_{xx}$  of combination, face to face arrangement will be better because it will lead to larger  $I_{\text{min}}$  for a given spacing.

8. (a)

$$\text{Elastic section modulus} = \frac{bh^2}{24}$$

$$\text{Plastic section modulus} = \frac{A}{2}(\bar{y}_1 + \bar{y}_2)$$

$$A = \frac{bh}{2}$$

$$\bar{y}_1 = \frac{h}{3\sqrt{2}}$$

$$\bar{y}_2 = 0.1548 h$$

$$\therefore Z_p = \frac{A}{2}(\bar{y}_1 + \bar{y}_2) = 0.0976 bh^2$$

$$\therefore \text{S.F.} = \frac{Z_p}{Z_y} = 2.343$$

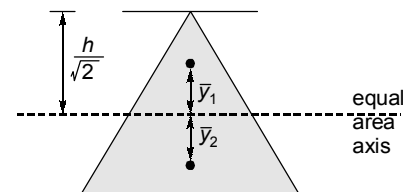

9. (b)

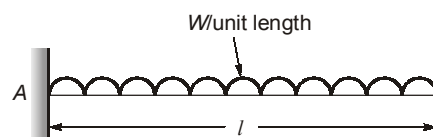

In plastic hinge occur at  $x$  distance from propped end

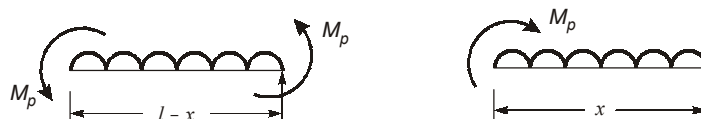

Now, 
$$M_p = \frac{wx^2}{2}$$

and 
$$M_p = \frac{w(l-x)^2}{4}$$

$\therefore x = 0.414 l$

Putting  $x$ , 
$$M_p = 0.085 wl^2$$

10. (a)

The connection in the lug angle with the gusset plate is designed for 1.2 times the force in outstanding leg.

$\therefore F = 1.2 \times 60 = 72 \text{ kN}$

11. (a)

$$\text{Bearing strength} = \frac{2.5k_b d.t.f_u}{\gamma_{m1}}$$

$$k_b = \text{minimum of } \left[ \frac{e}{3d_0}, \frac{p}{3d_0} - 0.25, \frac{f_{ub}}{f_u}, 1 \right]$$

$$= \text{minimum of } \left[ \frac{40}{3 \times 22}, \frac{60}{3 \times 22} - 0.25, \frac{400}{410}, 1 \right] = 0.606$$

$$\text{Bearing strength} = \frac{2.5 \times 0.606 \times 20 \times 20 \times 410}{1.25} = 198.77 \text{ kN}$$

12. (b)

In shear yielding and tension rupture

$$\text{Block shear strength} = \frac{f_y}{\sqrt{3}\gamma_{m1}} A_{vg} + \frac{0.9f_u}{\gamma_{m1}} A_{tn}$$

$$A_{vg} = (60 + 40) \times 20 \times 2 = 4000 \text{ mm}^2$$

$$A_{tn} = (100 - 2 \times 22) \times 20 = 1120 \text{ mm}^2$$

$$\text{Block shear strength} = \frac{250}{\sqrt{3} \times 1.1} \times 4000 + \frac{0.9 \times 410}{1.25} \times 1120 = 855.487 \text{ kN}$$

13. (d)

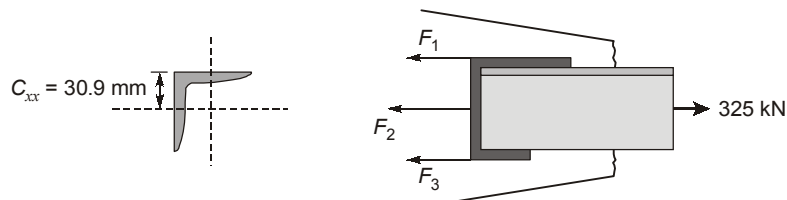

$$F_1 + F_2 + F_3 = 325 \text{ kN}$$

$$F_2 = \frac{350 \times 110}{1000} = 38.5 \text{ kN}$$

$$\Rightarrow F_1 + F_3 = 286.5 \text{ kN} \quad \dots(i)$$

For no torsional moment to develop,

$$F_1(30.9) - F_3(110 - 30.9) - F_2(55 - 30.9) = 0 \quad \dots(ii)$$

Solving (i) and (ii)

$$F_1 = 214.45 \text{ kN}$$

14. (a)

$$P = \frac{f_u}{\sqrt{3}\gamma_{mw}} \times t \times l$$

$$100 \times 10^3 = \frac{410}{\sqrt{3} \times 1.25} \times (0.707 \times 5) \times l$$

$$\therefore l = 149.38 \text{ mm}$$

15. (d)

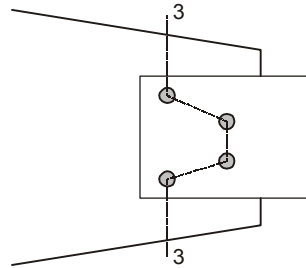

$$A_{\text{net } 3-3} = \left( 360 - 4 \times 20 + 2 \times \frac{60^2}{4 \times 60} \right) \times 10$$

$$A_{\text{net } 3-3} = 3100 \text{ mm}^2$$

16. (d)

When angles are not tack-rieveted, both the angles will act individually

$$\therefore A_{\text{net}} = 2[A_1 + kA_2]$$

$$k = \frac{3A_1}{3A_1 + A_2} = \frac{3 \times 775}{3 \times 775 + 950} = 0.7099$$

$$\therefore A_{\text{net}} = 2[775 + 0.7099 \times 950]$$

$$= 2899 \text{ mm}^2$$

17. (c)

$$I_{xx \text{ combi}} = 2 \times (I_{xx})_{\text{one ISMC}} + 2 \times \left[ \frac{240 \times 8^3}{12} + 240 \times 8 \times \left( \frac{175}{2} + 4 \right)^2 \right]$$

$$I_{xx} = 56.63 \times 10^6 \text{ mm}^4$$

$$I_{yy \text{ combi}} = 2 \times \left[ 121 \times 10^4 + 2438 \times \left( 22 + \frac{90}{2} \right)^2 + \frac{8 \times 240^3}{12} \right]$$

$$I_{yy} = 42.74 \times 10^6 \text{ mm}^4$$

$$I_{\text{min}} = 42.74 \times 10^6 \text{ mm}^4$$

$$\therefore A_{\text{total}} = 2 \times 2438 + 2 \times 240 \times 8 = 8716 \text{ mm}^2$$

$$r = \sqrt{\frac{I_{\text{min}}}{A_{\text{total}}}} = \sqrt{\frac{42.74 \times 10^6}{8716}} = 70.026 \text{ mm}$$

$$\therefore \lambda = \frac{6000}{70.026} = 85.68$$

19. (b)

$$t \geq \sqrt{\frac{2.5w(a^2 - \mu b^2)}{\left(\frac{f_y}{\gamma_{m0}}\right)}}$$

$$\therefore w = \frac{60 \times 10^3}{600^2} = \frac{1}{6} \text{ N/mm}^2$$

$$\therefore t \geq \sqrt{\frac{2.5 \times \frac{1}{6}}{\frac{250}{1.1}} \times (600^2 - 0.25 \times 600^2)}$$

$$\therefore t \geq 22.25 \text{ mm}$$

20. (a)

$$Z_e = 410 \times 10^3 \text{ mm}^3$$

$$I_{xx} \text{ of plates only} = 2 \left[ 100 \times \frac{10^3}{12} + 100 \times 10 \times \left( 125 + \frac{10}{2} \right)^2 \right]$$

$$= 33.8167 \times 10^6 \text{ mm}^4$$

$$Z_{xx} \text{ of plates only} = \frac{33.8167 \times 10^6}{(125 + 10)}$$

$$= 250.494 \times 10^3 \text{ mm}^3$$

$$Z_{xx} \text{ of whole section} = (250.494 + 410) \times 10^3$$

$$= 660.494 \times 10^3 \text{ mm}^3$$

$$\therefore \text{Enhanced moment capacity} = \frac{250}{1.1} \times 660.494 \times 10^3 \text{ N-mm}$$

$$= 150 \text{ kNm}$$

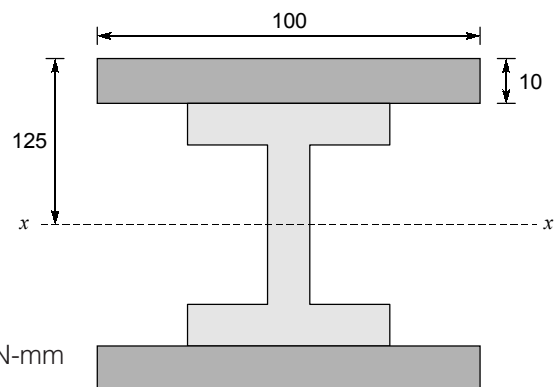

21. (a)

Total load supported by crane girder = 300 kN (250 + 50 kN)

Self weight of crane girder = 200 kN

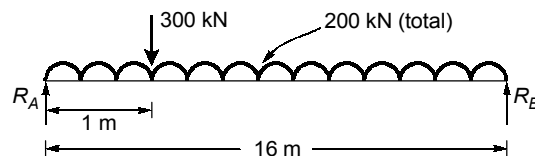

this load is transferred to gantry girder through 2 wheels,

$$\therefore R_A = \frac{300 \times 15}{16} + \frac{200}{2} = 381.25 \text{ kN}$$

$$\text{Load on gantry girder through each wheel} = \frac{381.25}{2} = 190.63 \text{ kN}$$

22. (a)

(ii) Strain distribution is linear so that plane section surface bending remains plane after bending.

(iii) Stress-strain curve is elastic-plastic.

23. (d)

$$w_{\text{collapse}} = \frac{16M_p}{l^2}$$

$$w_{\text{yield}} = \frac{12M_p}{l^2}$$

$$\Rightarrow \frac{w_{\text{collapse}}}{w_{\text{yield}}} = \frac{\frac{16M_p}{l^2}}{\frac{12M_p}{l^2}} = \frac{4}{3}$$

24. (b)

$$\text{Length of plastic hinge} = l\sqrt{1 - \frac{1}{SF}}$$

$$SF = \frac{3}{2}$$

$$\therefore \text{Length of plastic hinge} = \frac{l}{\sqrt{3}} = 0.577 l$$

26. (c)

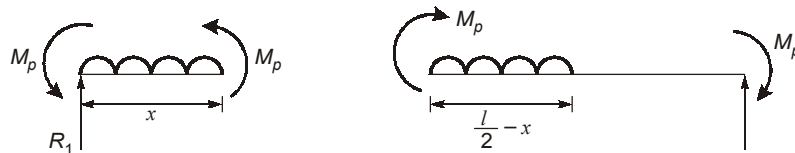

$$2M_p = \frac{wx^2}{2}$$

$$2M_p - w\left(\left(\frac{l}{2} - x\right) \times \left(\frac{l}{2} + \frac{1}{2}\left(\frac{l}{2} - x\right)\right)\right) = 0$$

$$x = \frac{3l}{8}$$

$$\therefore 2M_p = \frac{w\left(\frac{3l}{8}\right)^2}{2}$$

$$\therefore w = \frac{28.44M_p}{l^2}$$

27. (a)

$$D_s = 2$$

$\therefore$  No. of plastic hinges required for complete collapse

$$D_s + 1 = 2 + 1 = 3$$

**Mechanism-1**

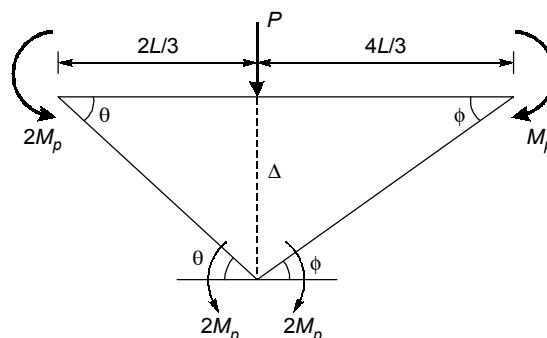

$$\Delta = \frac{2L}{3}\theta = \frac{4L}{3}\phi$$

$$\Rightarrow \theta = 2\phi$$

By principle of critical work done,

$$-2M_p\theta - 2M_p\theta - 2M_p\phi - M_p\phi + P\left(\frac{2L}{3}\theta\right) = 0$$

$$\Rightarrow 4 M_p\theta + 3 M_p\phi = \frac{2P_L}{3}\theta$$

$$\Rightarrow 8 M_p\phi + 3 M_p\phi = \frac{4P_L}{3}\phi$$

$$\Rightarrow P_u = \frac{33M_p}{4L}$$

$$\Rightarrow P_u = 8.25 M_p/L$$

**Mechanism-2**

$$2 M_p\theta + M_p\theta + M_p\theta + M_p\theta = P\left(\frac{2L}{3}\right)$$

$$\Rightarrow P_u = \frac{15}{2L} M_p$$

$$\Rightarrow P_u = \frac{7.5}{L} M_p$$

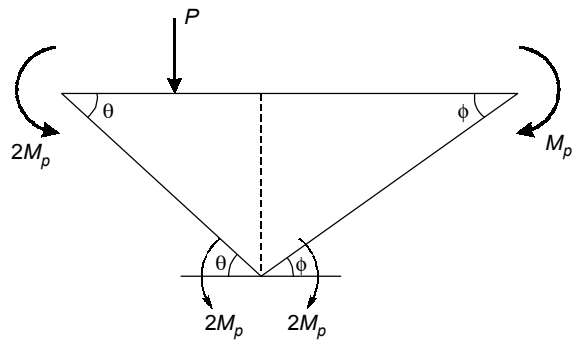

28. (c)

Bearing stiffeners are used to prevent local buckling and column splice has no role to play in shear capacity of steel girder.

29. (d)

For simultaneous collapse of AB and BC. Plastic hinge are formed at A, B and midspan of AB.

$$\therefore 2 M_p = \frac{wl^2}{8}$$

$$\therefore M_p = \frac{wl^2}{16}$$

$$M_p = \frac{wa^2}{2}$$

$$\therefore \frac{a^2}{2} = \frac{l^2}{16}$$

$$\therefore a = \frac{l}{2\sqrt{2}}$$

30. (c)

$$1.5 M_p = \frac{Pl}{4}$$

$$P = \frac{6M_p}{l}$$

