



**MADE EASY**

India's Best Institute for IES, GATE & PSUs

Delhi | Bhopal | Hyderabad | Jaipur | Lucknow | Pune | Bhubaneswar | Kolkata | Patna

Web: [www.madeeasy.in](http://www.madeeasy.in) | E-mail: [info@madeeasy.in](mailto:info@madeeasy.in) | Ph: 011-45124612

# DESIGN OF STEEL STRUCTURES

## CIVIL ENGINEERING

Date of Test : 20/07/2022

### ANSWER KEY >

1. (a)	7. (b)	13. (d)	19. (d)	25. (b)
2. (b)	8. (a)	14. (a)	20. (a)	26. (c)
3. (c)	9. (d)	15. (d)	21. (c)	27. (c)
4. (a)	10. (c)	16. (d)	22. (a)	28. (c)
5. (c)	11. (a)	17. (a)	23. (c)	29. (a)
6. (d)	12. (d)	18. (b)	24. (a)	30. (d)

**DETAILED EXPLANATIONS**

2. (b)

As  $I_{yy}$  of combination is less than  $I_{xx}$  of combination, face to face arrangement will be better because it will lead to larger  $I_{min}$  for a given spacing.

4. (a)

$$\text{Elastic section modulus} = \frac{bh^2}{24}$$

$$\text{Plastic section modulus} = \frac{A}{2}(\bar{y}_1 + \bar{y}_2)$$

$$A = \frac{bh}{2}$$

$$\bar{y}_1 = \frac{h}{3\sqrt{2}}$$

$$\bar{y}_2 = 0.1548h$$

$$\therefore z_p = \frac{A}{2}(\bar{y}_1 + \bar{y}_2) = 0.0976bh^2$$

$$\therefore \text{S.F.} = \frac{z_p}{z_y} = 2.343$$

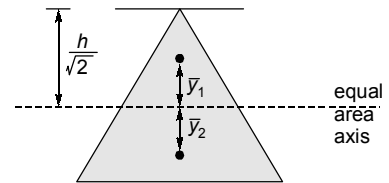

8. (a)

When  $\theta < 60^\circ$

The design force for connection is  $V \cot \theta$ .

$$V = \frac{2.5}{100} \times 750 = 18.75 \text{ kN}$$

$$\therefore V \cot 45^\circ = 18.75 \text{ kN.}$$

9. (d)

$$\text{Length of plastic hinge} = l \left( 1 - \frac{1}{\text{S.F.}} \right) = 6 \times \left( 1 - \frac{1}{3/2} \right) = 2 \text{ m}$$

11. (a)

$$\text{Bearing strength} = \frac{2.5k_b d t f_u}{\gamma_{m1}}$$

$$k_b = \text{minimum of} \left[ \frac{e}{3d_0}, \frac{p}{3d_0} - 0.25, \frac{f_{ub}}{f_u}, 1 \right]$$

$$= \text{minimum of} \left[ \frac{40}{3 \times 22}, \frac{60}{3 \times 22} - 0.25, \frac{400}{410}, 1 \right] = 0.606$$

$$\text{Bearing strength} = \frac{2.5 \times 0.606 \times 20 \times 20 \times 410}{1.25} = 198.77 \text{ kN}$$

12. (d)

For simultaneous collapse of  $AB$  and  $BC$ . Plastic hinge are formed at  $A$ ,  $B$  and midspan of  $AB$ .

$$\begin{aligned} \therefore 2 M_p &= \frac{wl^2}{8} \\ \therefore M_p &= \frac{wl^2}{16} \\ M_p &= \frac{wa^2}{2} \\ \therefore \frac{a^2}{2} &= \frac{l^2}{16} \\ \therefore a &= \frac{l}{2\sqrt{2}} \end{aligned}$$

13. (d)

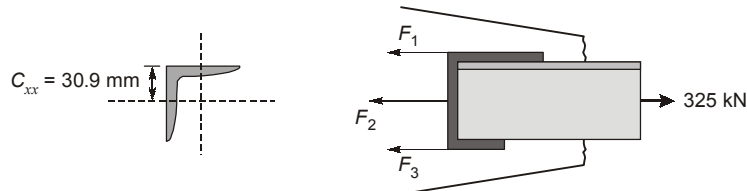

$$F_1 + F_2 + F_3 = 325 \text{ kN}$$

$$F_2 = \frac{350 \times 110}{1000} = 38.5 \text{ kN}$$

$$\Rightarrow F_1 + F_3 = 286.5 \text{ kN} \quad \dots(i)$$

For no torsional moment to develop,

$$F_1(30.9) - F_3(110 - 30.9) - F_2(55 - 30.9) = 0 \quad \dots(ii)$$

Solving (i) and (ii)

$$F_1 = 214.45 \text{ kN}$$

14. (a)

$$P = \frac{f_u}{\sqrt{3} \gamma_{mw}} \times t \times l$$

$$100 \times 10^3 = \frac{410}{\sqrt{3} \times 1.25} \times (0.707 \times 5) \times l$$

$$\therefore l = 149.38 \text{ mm}$$

15. (d)

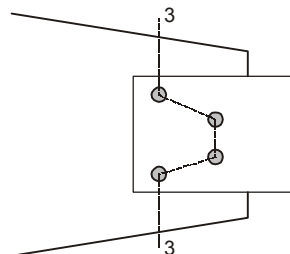

$$A_{\text{net } 3-3} = \left( 360 - 4 \times 20 + 2 \times \frac{60^2}{4 \times 60} \right) \times 10$$

$$A_{\text{net } 3-3} = 3100 \text{ mm}^2$$

16. (d)

When angles are not tack-reveted, both the angles will act individually

$$\therefore A_{\text{net}} = 2[A_1 + kA_2]$$

$$k = \frac{3A_1}{3A_1 + A_2} = \frac{3 \times 775}{3 \times 775 + 950} = 0.7099$$

$$\therefore A_{\text{net}} = 2[775 + 0.7099 \times 950] = 2899 \text{ mm}^2$$

18. (b)

$$t \geq \sqrt{\frac{2.5w(a^2 - \mu b^2)}{\left(\frac{f_y}{\gamma_{m0}}\right)}}$$

$$\therefore w = \frac{60 \times 10^3}{600^2} = \frac{1}{6} \text{ N/mm}^2$$

$$\therefore t \geq \sqrt{\frac{2.5 \times \frac{1}{6}}{\frac{250}{1.1}} \times (600^2 - 0.25 \times 600^2)}$$

$$\therefore t \geq 22.25 \text{ mm}$$

19. (d)

$$W_{\text{collapse}} = \frac{16M_p}{l^2}$$

$$W_{\text{yield}} = \frac{12M_p}{l^2}$$

$$\Rightarrow \frac{W_{\text{collapse}}}{W_{\text{yield}}} = \frac{\frac{16M_p}{l^2}}{\frac{12M_p}{l^2}} = \frac{4}{3}$$

20. (a)

$$D_s = 2$$

\(\therefore\) No. of plastic hinges required for complete collapse

$$D_s + 1 = 2 + 1 = 3$$

Mechanism-1

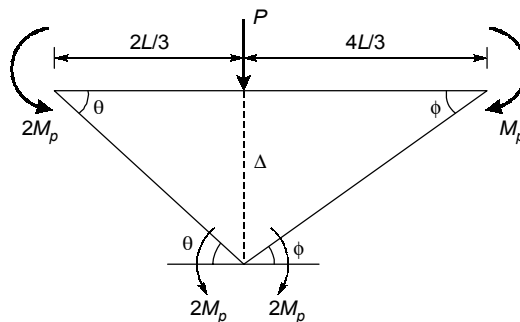

$$\Delta = \frac{2L}{3}\theta = \frac{4L}{3}\phi$$

$$\Rightarrow \theta = 2\phi$$

By principle of critical work done,

$$-2M_p\theta - 2M_p\theta - 2M_p\phi - M_p\phi + P\left(\frac{2L}{3}\theta\right) = 0$$

$$\Rightarrow 4M_p\theta + 3M_p\phi = \frac{2P_L}{3}\theta$$

$$\Rightarrow 8M_p\phi + 3M_p\phi = \frac{4P_L}{3}\phi$$

$$\Rightarrow P_u = \frac{33M_p}{4L}$$

$$\Rightarrow P_u = 8.25 M_p/L$$

**Mechanism-2**

$$2M_p\theta + M_p\theta + M_p\theta + M_p\theta = P\left(\frac{2L}{3}\right)$$

$$\Rightarrow P_u = \frac{15}{2L}M_p$$

$$\Rightarrow P_u = \frac{7.5}{L}M_p$$

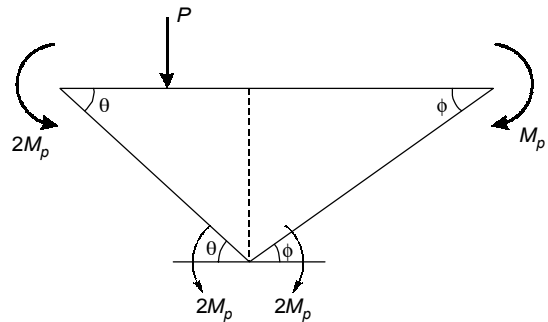
**21. (c)**

Bearing stiffeners are used to prevent local buckling and column splice has no role to play in shear capacity of steel girder.

**22. (a)**

$$\text{Vertical force on rivet 1} = \frac{P}{4} = \frac{54.8}{4} = 13.7 \text{ kN}$$

$$\text{Moment to which the rivet is subjected} = 54.8 \times 0.25 = 13.7 \text{ kNm}$$

$$\text{Force acting on rivet 1 due to moment, } r = \sqrt{80^2 + 80^2} \approx 113.1 \text{ mm}$$

$$\frac{M \times r}{4r^2} = \frac{13.7 \times 0.113}{4 \times 0.113^2} = 30.27 \text{ kN}$$

$$\text{Net force acting} = \sqrt{F_1^2 + F_2^2 + 2F_1F_2 \cos\theta}$$

$$= \sqrt{13.7^2 + 30.27^2 + 2 \times 13.7 \times 30.27 \times \frac{1}{\sqrt{2}}} = 41.11 \text{ kN}$$

24. (a)

Total load supported by crane girder = 300 kN (250 + 50 kN)

Self weight of crane girder = 200 kN

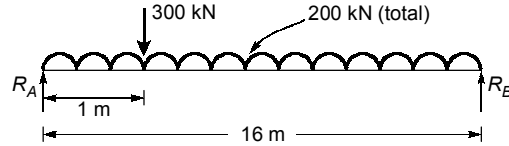

this load is transferred to gantry girder through 2 wheels,

$$\therefore R_A = \frac{300 \times 15}{16} + \frac{200}{2} = 381.25 \text{ kN}$$

$$\text{Load on gantry girder through each wheel} = \frac{381.25}{2} = 190.63 \text{ kN}$$

25. (b)

$$f_{cd} = \frac{x f_y}{\gamma_{m0}} \quad \left(\text{where, } x = \frac{1}{\phi + \sqrt{\phi^2 - \lambda_e^2}}\right)$$

$$\phi = [(1 + \alpha(\lambda_e - 0.2) + \lambda_e^2)] \times 0.5$$

$$\lambda_e = \sqrt{\frac{f_y}{\pi^2 E}} = 0.416$$

$$\phi = 0.64$$

$$x = 0.89$$

$$f_{cd} = \frac{0.89 \times 250}{1.1} = 202.27 \text{ N/mm}^2$$

26. (c)

$$\text{Design strength of weld, } P_{dw} = l_w \times t_t \times \frac{f_u}{\sqrt{3} \gamma_{mw}} \quad \dots(i)$$

Minimum permissible weld size upto 20 mm thick plate as per **IS 800:2007** is

$$s = 5 \text{ mm}$$

$$t_t = 0.7 \times 5 = 3.5 \text{ mm} \quad (> 3 \text{ mm})$$

Substituting in equation (i)

$$\Rightarrow 200 \times 10^3 = l_w \times 3.5 \times \frac{410}{\sqrt{3} \times 1.5}$$

$$\Rightarrow l_w = 362.1 \text{ mm}$$

27. (c)

$$I_{xx} = 2(I_{xx})_{\text{only}} = 54.4 \times 10^4 \text{ mm}^4$$

$$I_{yy} = 2[(I_{yy})_{\text{one}} + A_{\text{one}} [C_{yy} + s/2]^2]$$

$$= 2[8.8 \times 10^4 + 552[10.4 + s/2]^2]$$

$$I_{xx} = I_{yy}$$

$$27.2 \times 10^4 = 8.8 \times 10^4 + 552 (10.4 + s/2)^2$$

$$\therefore s = 15.7 \text{ mm}$$

28. (c)

Since in purlins, maximum moment about both the principal axes are not equal i.e., one moment is lesser than the other. So, there is no point in giving equal section modulus in both the principal axes. Hence, equal angles are not economical in case of purlins.

29. (a)

Failure in the left/right span can be caused by formation of two hinges.

Using virtual work method

$$\Rightarrow P \cdot \frac{L}{2} \theta = M_P \cdot (2\theta) + 0.6M_P \cdot \theta$$

$$\Rightarrow P = \frac{5.2M_P}{L}$$

The failure in the middle span will be caused by formation of 3 hinges.

$$\Rightarrow P \cdot \frac{L}{2} \cdot \theta = 0.6M_P (\theta + 2\theta + \theta)$$

$$\Rightarrow P = \frac{4.8M_P}{L}$$

Hence, collapse load is the minimum of the above two values, i.e.  $\frac{4.8M_P}{L}$ .

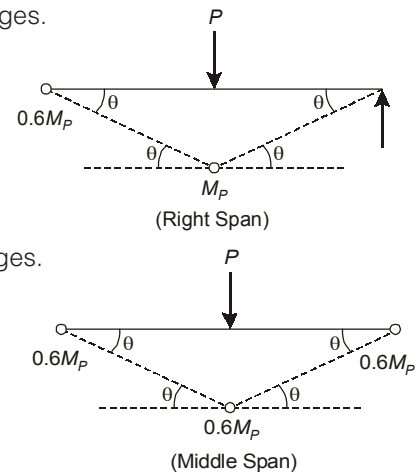

30. (d)

$$\text{Total area of cross-section} = 40 \times 100 + 100 \times 20 = 6000 \text{ mm}^2$$

For equal area axis

$$40 \times y = \frac{6000}{2}$$

$$\therefore y = 75 \text{ mm}$$

