

CLASS TEST

S.No. : 02 GH1_ME_E+G_220619

Heat and Mass Transfer



MADE EASY

India's Best Institute for IES, GATE & PSUs

Delhi | Noida | Bhopal | Hyderabad | Jaipur | Lucknow | Indore | Pune | Bhubaneswar | Kolkata | Patna

Web: www.madeeasy.in | E-mail: info@madeeasy.in | Ph: 011-45124612

CLASS TEST 2019-2020

MECHANICAL ENGINEERING

Date of Test : 22/06/2019

ANSWER KEY > Heat and Mass Transfer

- | | | | | |
|--------|---------|---------|---------|---------|
| 1. (b) | 7. (c) | 13. (c) | 19. (c) | 25. (b) |
| 2. (d) | 8. (c) | 14. (a) | 20. (b) | 26. (b) |
| 3. (c) | 9. (b) | 15. (c) | 21. (b) | 27. (c) |
| 4. (c) | 10. (d) | 16. (d) | 22. (c) | 28. (a) |
| 5. (d) | 11. (d) | 17. (a) | 23. (b) | 29. (b) |
| 6. (b) | 12. (b) | 18. (b) | 24. (a) | 30. (b) |

DETAILED EXPLANATIONS

3. (c)

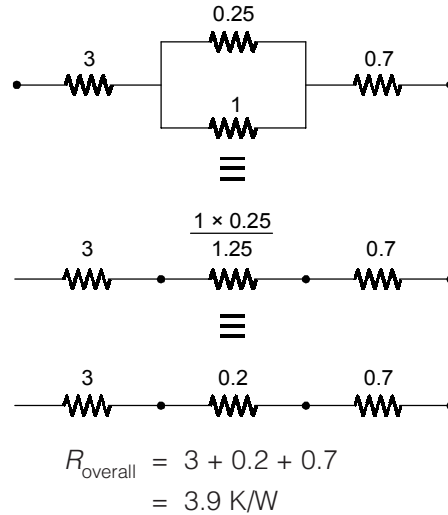

4. (c)

Nusselt equation for film-type condensation on a vertical plate is given as:

$$Nu_x = \frac{h_x x}{k} = \left[\frac{\rho_f (\rho_f - \rho_v) g h_{fg} x^3}{4 \mu_f k_f \theta} \right]^{1/4}$$

As given,

$$\frac{Nu_2}{Nu_1} = \left(\frac{\theta_1}{\theta_2} \right)^{0.25} \quad [\text{Keeping other parameters constant}]$$

$$\theta_1 = 100 - 10 = 90^\circ\text{C or } 90 \text{ K}$$

$$\theta_2 = 100 - 55 = 45^\circ\text{C or } 45 \text{ K}$$

$$\frac{Nu_2}{Nu_1} = \left(\frac{90}{45} \right)^{0.25} = (2)^{0.25} = 1.189 \approx 1.19$$

6. (b)

Material	Thermal conductivity, $k(\text{W/mK})$
Copper	380
Aluminium, pure	225
Aluminium, alloy	156
Magnesium, pure	173
Steel	55
Stainless steel	14

9. (b)

General heat conduction equation in cylindrical coordinates is given as

$$\frac{1}{r} \frac{\partial}{\partial r} \left(r \frac{\partial T}{\partial r} \right) + \frac{1}{r^2} \frac{\partial^2 T}{\partial \theta^2} + \frac{\partial^2 T}{\partial z^2} + \frac{q_G}{k} = \frac{1}{\alpha} \frac{\partial T}{\partial t}$$

For one-dimensional i.e., $T = T(r, t)$, the equation reduces to

$$\frac{1}{r} \frac{\partial}{\partial r} \left(r \frac{\partial T}{\partial r} \right) = \frac{1}{\alpha} \frac{\partial T}{\partial t}$$

We know that $\alpha = \frac{k}{\rho c_p}$ i.e., this equation can be re-written as

$$\rho c_p \frac{\partial T}{\partial t} = \frac{1}{r} \frac{\partial}{\partial r} \left(r k \frac{\partial T}{\partial r} \right) \quad [\text{Here, } n = 1]$$

11. (d)

For steady state condition:

$$\begin{aligned} \frac{-T + 1200}{\left(\frac{t}{2k}\right)} &= \frac{T - 400}{\left(\frac{2t}{k}\right)} \\ 2(1200 - T) \times 2 &= T - 400 \\ 4(1200 - T) &= T - 400 \\ 4 \times 1200 - 4T &= T - 400 \\ 5T &= 4800 + 400 = 5200 \\ T &= 1040 \text{ K} \\ \Delta T_A &= 1200 - 1040 = 160 \text{ K} \end{aligned}$$

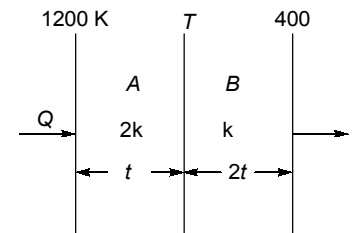

12. (b)

$$k_1 = 0.7 \text{ W/mK}$$

$$k_2 = 0.2 \text{ W/mK}$$

Heat transfer before insulation $Q_1 = -k_1 A \frac{\Delta T}{t_1} = -k_1 A \left(\frac{\Delta T}{0.2} \right)$

After applying insulation, heat transfer decreases by 75%.

$$Q_2 = \frac{\Delta T}{\frac{0.2}{k_1 A} + \frac{t_2}{k_2 A}}$$

for unit area,

$$A = 1 \text{ m}^2$$

As given,

$$Q_2 = 0.25 Q_1$$

$$\frac{\Delta T}{\frac{0.2}{0.7} + \frac{t_2}{0.2}} = \frac{\Delta T}{\left(\frac{0.2}{0.7}\right)} \times 0.25$$

$$\frac{t_2}{0.2} + \frac{0.2}{0.7} = \frac{8}{7}$$

$$t_2 = \left(\frac{8}{7} - \frac{2}{7} \right) 0.2 = \frac{6}{7} \times 0.2 = 0.17143 \text{ m or } 17.143 \text{ cm}$$

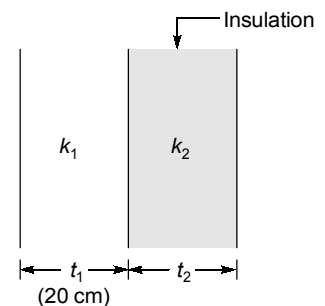

13. (c)

$$h_w \text{ (hot fluid)} = 2850 \text{ W/m}^2 \text{ K}$$

$$h_a \text{ (cold fluid)} = 10 \text{ W/m}^2 \text{ K}$$

$$k \text{ (Thermal conductivity)} = 50 \text{ W/mK}$$

$$Q = U(t_w - t_a) \text{ (for } A = 1 \text{ m}^2\text{)}$$

$$\frac{1}{U} = \frac{1}{h_w} + \frac{L}{k} + \frac{1}{h_a}$$

$$= \frac{1}{2850} + \frac{0.012}{50} + \frac{1}{10} = 0.10059$$

$$U = \frac{1}{0.1006} = 9.9412 \text{ W/m}^2 \text{ K}$$

$$Q = 9.9412 (95 - 15) = 9.9412 \times 80 = 795.3 \text{ W/m}^2$$

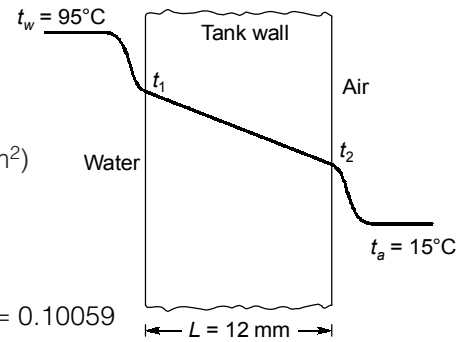

14. (a)

$$\text{Inner radius of pipe, } r_i = \frac{80}{2} = 40 \text{ mm} = 0.04 \text{ m}$$

$$\text{Outer radius of pipe, } r_o = \frac{100}{2} = 50 \text{ mm} = 0.05 \text{ m}$$

$$\text{Temperature of hot gases, } T_i = 160^\circ\text{C}$$

$$\text{Temperature of ambient, } T_0 = 25^\circ\text{C}$$

$$\text{Thermal conductivity of pipe material, } k = 180 \text{ W/mK}$$

$$Q = \frac{\Delta T}{R_{th}} = \frac{T_i - T_0}{\frac{\ln(r_o/r_i)}{2\pi kL}} = \left[\frac{160 - 25}{\ln\left(\frac{0.05}{0.04}\right)} \right] \times 2\pi \times 180$$

$$= 684229 \text{ W} = 684.23 \text{ kW}$$

15. (c)

$$\text{Critical radius of insulation, } r_c = \frac{k}{h_a} = \frac{0.2}{15} \times 100 = 1.33 \text{ cm}$$

$$\text{Critical thickness of insulation} = 1.33 - 1 = 0.33 \text{ cm}$$

16. (d)

General solution for the temperature distribution is

$$\theta = C_1 e^{-mx} + C_2 e^{mx}$$

where

$$m = \left(\frac{hP}{kA} \right)^{1/2}$$

At $x = 0$, $\theta = \theta_0$ and at $x = \infty$, $\theta = 0$

$$C_2 = 0, C_1 + C_2 = \theta_0$$

$$C_1 = \theta_0$$

$$\theta = C_1 e^{-mx} = \theta_0 e^{-mx}$$

Let l be the distance between the two points where the temperature are measured.

$$\theta_1 = \theta_0 e^{-mx_1} \text{ and } \theta_2 = \theta_0 e^{-mx_2}$$

$$\frac{\theta_1}{\theta_2} = e^{-m(x_1 - x_2)} = e^{m(x_2 - x_1)} = e^{ml}$$

$$\frac{130 - 25}{90 - 25} = \frac{105}{65} = 1.6154 = e^{ml}$$

$$ml = 0.4796$$

$$m = \frac{0.4796}{0.08} = 5.9946 = \left(\frac{hP}{kA}\right)^{1/2} = \left(\frac{h\pi d}{k \frac{\pi d^2}{4}}\right)^{1/2} = 2 \times \sqrt{\frac{h}{kd}}$$

$$m^2 = 4 \times \frac{h}{kd}$$

$$k = \frac{4h}{m^2 d} = \frac{4 \times 23.36}{(5.9946)^2 \times 0.025} = 104 \text{ W/mK}$$

17. (a)
 Fin effectiveness is proportional to $\left(\frac{kP}{hA}\right)^{1/2}$
 $\epsilon_f \uparrow$ if $k \uparrow$
 $\epsilon_f \uparrow$ if $h \downarrow$
 $\epsilon_f \uparrow$ if $(P/A) \uparrow$

18. (b)

$$L = \frac{V}{A} = \frac{1}{6} \pi D^3 \times \frac{1}{\pi D^2} = \frac{D}{6}$$

$$\text{Biot number, } Bi = \frac{hL}{k} = \frac{hD}{6k} = \frac{400 \times 0.8 \times 10^{-3}}{6 \times 20} = 2.67 \times 10^{-3}$$

Here, $Bi < 0.1$. Therefore, lumped system analysis can be used

$$\frac{T - T_\infty}{T_i - T_\infty} = \exp\left[-\frac{hAt}{\rho CV}\right]$$

$$\frac{285 - 290}{25 - 290} = \exp\left[-\frac{400 \times 6 \times t}{8500 \times 0.8 \times 10^{-3} \times 400}\right]$$

$$0.018868 = \exp[-0.882353 t]$$

$$\text{Time, } t = \frac{3.97}{0.882353} \approx 4.5 \text{ seconds}$$

19. (c)

Characteristic length of tube, $L = \text{diameter, } D$

$$Nu \propto \left[\frac{g\beta(T_w - T_\infty)L^3}{\nu^2}\right]^{0.25}$$

$$h \propto (L^{-1})(L^{0.75}) \quad \left(\because Nu = \frac{hL}{k}\right)$$

$$h \propto L^{-0.25}$$

$$\propto D^{-0.25}$$

$$\frac{h_2}{h_1} = \left(\frac{D_2}{D_1}\right)^{-1/4} = \left(\frac{16}{4}\right)^{-1/4} = \frac{1}{\sqrt{2}}$$

$$h_2 = \frac{100}{\sqrt{2}} = 70.71 \text{ W/m}^2\text{K}$$

20. (b)

$$\text{Prandtl number, Pr} = \frac{\mu c_p}{k} = \frac{0.232 \times 10^{-4} \times 1005}{33.2 \times 10^{-3}} = 0.7023$$

$$T_{\text{mean}} = \frac{171 + 93.4}{2} = 132.2^\circ\text{C} = 405.2 \text{ K}$$

$$\beta = \frac{1}{T_{\text{mean}}} = 2.47 \times 10^{-3} \text{ K}^{-1}$$

$$\theta = T_W - T_\infty = 171 - 93.4 = 77.6^\circ\text{C} = 77.6 \text{ K}$$

$$\rho = \frac{P}{RT} = \frac{101.325}{0.287 \times 405.2} = 0.8713 \text{ kg/m}^3$$

$$v = \frac{\mu}{\rho} = \frac{0.232 \times 10^{-4}}{0.8713} = 2.663 \times 10^{-5} \text{ m}^2/\text{s}$$

$$\text{Gr} = \frac{g\beta\theta L^3}{v^2} = \frac{9.81 \times 2.47 \times 10^{-3} \times 77.6 \times (0.7)^3}{(2.663 \times 10^{-5})^2} = 9.0945 \times 10^8$$

$$\text{Nu} = 0.548 (9.0945 \times 10^8 \times 0.7023)^{0.25} = 87.117$$

$$\frac{h_m L}{k} = 87.117$$

$$h_m = \frac{87.117 \times 33.2 \times 10^{-3}}{0.7} = 4.1318 \text{ W/m}^2\text{K}$$

21. (b)

$$\text{Reynolds number, Re} = \frac{\rho V D}{\mu} = \frac{950 \times 2 \times 0.035}{2.55 \times 10^{-4}} = 2.6 \times 10^5 > 2100 \text{ (for tube/pipe flow)}$$

So, the flow is turbulent.

$$\begin{aligned} \text{Nu} &= \frac{hD}{k} = 0.023(\text{Re})^{0.8}(\text{Pr})^{0.4} = 0.023(2.6 \times 10^5)^{0.8} \left(\frac{2.55 \times 10^{-4} \times 4.23 \times 10^3}{0.685} \right)^{0.4} \\ &= 0.023 \times 21529.065 \times 1.19916 = 593.786 \end{aligned}$$

$$h = \frac{593.786 \times 0.685}{0.035} = 11.62 \times 10^3 \text{ W/m}^2\text{K}$$

23. (b)

$$\text{Nu} = \frac{hD}{k} = 3.66 \quad (\text{for uniform wall temperature})$$

$$h = 3.66 \frac{k}{D} = \frac{3.66 \times 0.175}{0.006} = 106.75 \text{ W/m}^2\text{K}$$

24. (a)

$$\begin{aligned} Q &= A_1 F_{12} (E_{b1} - E_{b2}) = \sigma A_1 F_{12} (T_1^4 - T_2^4) \\ &= 5.67 \times 10^{-8} \times 1 \times 0.415 [(900 + 273)^4 - (400 + 273)^4] \\ &= 3.97 \times 10^4 = 39.7 \text{ kW} \end{aligned}$$

25. (b)

$$A_1 F_{12} = A_2 F_{21}$$

$$F_{22} + F_{21} = 1 \Rightarrow F_{21} = 1 \quad (\text{because } F_{22} = 0)$$

$$F_{12} = \frac{A_2}{A_1} = \frac{4\pi a^2}{4\pi b^2} = \left(\frac{a}{b}\right)^2$$

$$F_{11} + F_{12} = 1$$

$$F_{11} = 1 - F_{12} = 1 - \left(\frac{a}{b}\right)^2$$

26. (b)

- (i) Glass is transparent at short wavelengths
 (ii) Thermal radiation wavelength range – 0.1 to 100 μm

27. (c)

The ratio of radiant energy transfer without and with shield is given by $\frac{\left(\frac{1}{\epsilon_1} + \frac{1}{\epsilon_2} - 1\right)}{\left(\frac{1}{\epsilon_1} + \frac{1}{\epsilon_s} - 1\right) + \left(\frac{1}{\epsilon_s} + \frac{1}{\epsilon_2} - 1\right)}$
 We have $\epsilon_1 = \epsilon_2 = 0.5$, $\epsilon_s = 0.25$

$$\frac{Q_1}{Q_2} = \frac{\left(\frac{1}{0.5} + \frac{1}{0.5} - 1\right)}{\left(\frac{1}{0.5} + \frac{1}{0.25} - 1\right) + \left(\frac{1}{0.5} + \frac{1}{0.25} - 1\right)} = \frac{3}{(2+4-1) + (2+4-1)} = \frac{3}{10}$$

28. (a)

$Q_H = 0.01 \text{ m}^3/\text{min}$; $Q_C = 0.05 \text{ m}^3/\text{min}$; $\rho_C = 800 \text{ kg/m}^3$; $\rho_H = 1000 \text{ kg/m}^3$; $c_{PC} = 2 \text{ kJ/kgK} = 2000 \text{ J/kgK}$
 $c_{PH} = 4180 \text{ J/kgK}$

For steady state heat balance:

$$\dot{m}_H c_{PH} (T_{H1} - T_{H2}) = \dot{m}_C c_{PC} (T_{C1} - T_{C2})$$

$$1000 \times 0.01 \times 4180 (80 - 50) = 800 \times 0.05 \times 200 (T_{C2} - 20)$$

$$T_{C2} = 35.675^\circ\text{C}$$

$$\Delta T_1 = 80 - 20 = 60^\circ\text{C}$$

$$\Delta T_2 = 50 - 35.675 = 14.325^\circ\text{C}$$

$$\text{LMTD} = \frac{\Delta T_1 - \Delta T_2}{\ln\left(\frac{\Delta T_1}{\Delta T_2}\right)} = \frac{60 - 14.325}{\ln\left(\frac{60}{14.325}\right)} \approx 32^\circ\text{C}$$

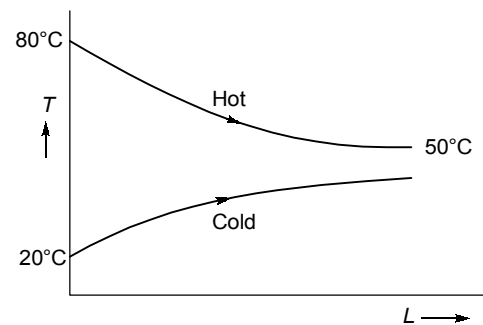

29. (b)

$$\frac{1}{U'_o} = \frac{1}{U_o} + R_f$$

$$\frac{1}{U'_o} = \frac{1}{400} + 0.0005$$

$$U'_o = 333.33 \text{ W/m}^2\text{K}$$

30. (b)

$$\epsilon = \frac{1 - \exp[-N(1-C)]}{1 - C \exp[-N(1-C)]}, \quad \epsilon = \frac{N}{1+N} \text{ when } C = 1$$

$$\epsilon = \frac{0.6}{1.6} = 0.375$$

