



MADE EASY
India's Best Institute for IES, GATE & PSUs

Delhi | Noida | Bhopal | Hyderabad | Jaipur | Lucknow | Indore | Pune | Bhubaneswar | Kolkata | Patna
Web: www.madeeasy.in | E-mail: info@madeeasy.in | Ph: 011-45124612

**CLASS TEST
2019-20**

**ELECTRICAL
ENGINEERING**

Subject : Analog Electronics

Date of test : 03/04/2019

Answer Key

-
- | | | | | |
|--------|---------|---------|---------|---------|
| 1. (b) | 7. (b) | 13. (c) | 19. (d) | 25. (c) |
| 2. (a) | 8. (a) | 14. (c) | 20. (c) | 26. (a) |
| 3. (a) | 9. (b) | 15. (a) | 21. (a) | 27. (c) |
| 4. (d) | 10. (b) | 16. (b) | 22. (c) | 28. (d) |
| 5. (d) | 11. (d) | 17. (d) | 23. (d) | 29. (b) |
| 6. (a) | 12. (b) | 18. (d) | 24. (b) | 30. (c) |
-

Detailed Explanations

1. (b)

Since there is a D.C level shift in the output waveform, the circuit must be a clamper circuit and when the diode is conducting, the voltage at the output must be 5 V as seen from the output waveform hence option (b) is correct.

2. (a)

$$I_{DC} = \frac{V_m}{\pi(R_f + R_L)} = \frac{10}{\pi(100 + 1000)}$$

$$= \frac{10 / \pi}{1100} = \frac{10}{\pi \times 1.1} \text{ mA} = 2.9 \text{ mA}$$

3. (a)

In voltage - voltage feedback, the input impedance increases by a factor $(1 + A\beta)$ and output impedance decreases by a factor $(1 + A\beta)$.

$$1 + A\beta = 1 + Ak$$

$$= 1 + 10^{-3} \times 10^3 = 2$$

thus

$$Z_{if} = 2 \text{ k}\Omega$$

$$Z_{of} = 50 \Omega$$

4. (d)

$$\text{the value of } V_{out} = \left(1 + \frac{R_2}{R_1}\right) V_z$$

$$9 = \left(1 + \frac{R_2}{R_1}\right) 3$$

$$1 + \frac{R_2}{R_1} = 3$$

$$\frac{R_2}{R_1} = 2$$

$$\therefore \frac{R_1}{R_2} = 0.5$$

5. (d)

When the cathode voltage of two parallel diodes is same, the diode with more forward biasing anode voltage will be in ON state and the other diode will be in OFF state.

Hence D_1 will be in OFF state and D_2 will be in ON state.

$$\text{Thus } V_0 = 3 - 0.7 = 2.3 \text{ V}$$

$$I_0 = \frac{2.3 - 0}{1 \text{ k}\Omega} = 2.3 \text{ mA}$$

6. (a)

The feedback element (R_f) is directly connected to both input and output. So, voltage-shunt type of feedback.

7. (b)

$$V_0 = -(6 \text{ mA})(6 \text{ k}\Omega) = -36 \text{ V}$$

$$I_0 + 6 \text{ mA} = \frac{V_0}{2K}$$

$$I_0 + 6 \text{ mA} = \frac{-36}{2 \times 10^3} = -18 \text{ mA}$$

$$I_0 = -24 \text{ mA}$$

8. (a)

At $f = 0$, inductor is short circuited and capacitor is open circuited.

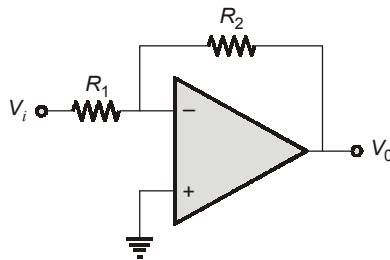

$$V_0 = -V_i \left(\frac{R_2}{R_1} \right)$$

At $f = \infty$, inductor is open circuited and capacitor is short circuited.

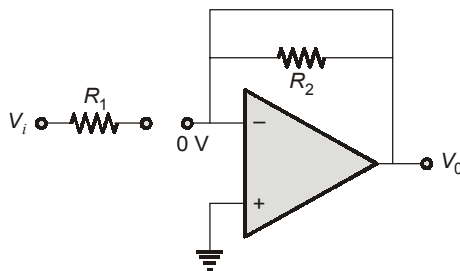

Voltage follower, $V_0 = 0$

Thus circuit acts as a low pass filter.

9. (b)

Current gain for darlington pair

$$= (1 + \beta)^2 = (1 + 20)^2$$

$$= 21 \times 21 = 441$$

10. (b)

$$I_C = \beta I_B + (1 + \beta) I_{CO}$$

$$I_C = \beta I_B + \left(1 + \frac{\alpha}{1 - \alpha} \right) I_{CO}$$

$$I_C = \beta I_B + \frac{I_{CO}}{1 - \alpha}$$

11. (d)

Given $g_m = 40 \mu\text{A/V}$
AC equivalent circuit to determine R_0 ,

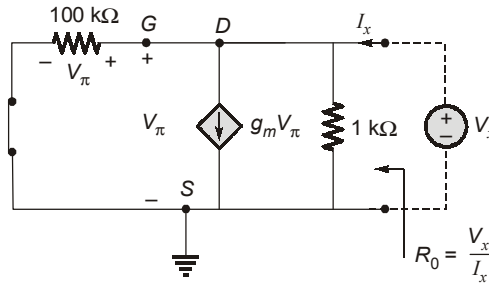

$$I_x = g_m V_\pi + \frac{V_\pi}{100 \text{ k}\Omega} + \frac{V_\pi}{1 \text{ k}\Omega}$$

$$V_\pi = V_x$$

$$R_0 = \frac{V_x}{I_x} = \frac{1}{g_m + \frac{1}{100 \text{ k}\Omega} + \frac{1}{1 \text{ k}\Omega}} = \frac{1}{(40 \times 10^{-6}) + (10 \times 10^{-6}) + 10^{-3}} \Omega$$

$$R_0 = \frac{1000}{1.05} \Omega = 952.38 \Omega$$

12. (b)

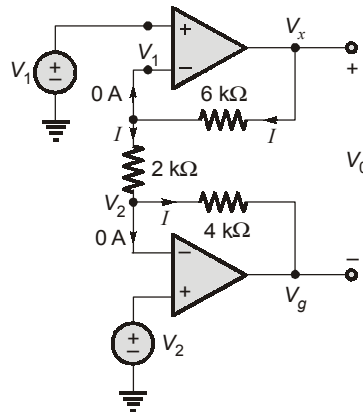

$$V_0 = I(6 \text{ k} + 2 \text{ k} + 4 \text{ k}) = I(12 \text{ k})$$

$$I = \frac{V_1 - V_2}{2 \text{ k}}$$

$$V_0 = \frac{V_1 - V_2}{2 \text{ k}} (12 \text{ k})$$

So, $A_{vd} = \frac{V_0}{V_1 - V_2} = 6$

13. (c)

For both M_1 and M_2 , $V_D = V_G$
So, both are in saturation mode

$$\Rightarrow \begin{aligned} 3 &= V_{gs1} + V_{gs2} \\ V_2 &= V_{gs2} = 1.5 \text{ V} \end{aligned}$$

$$I_1 = \frac{1}{2} \mu_n C_{ox} \left(\frac{W}{L} \right) (V_{gs} - V_{Th})^2$$

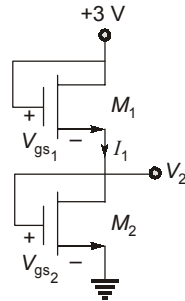

$$= \frac{1}{2} \times 20 \times 3 (1.5 - 1)^2 = 7.5 \mu\text{A}$$

14. (c)

The midband ac equivalent circuit of the given amplifier

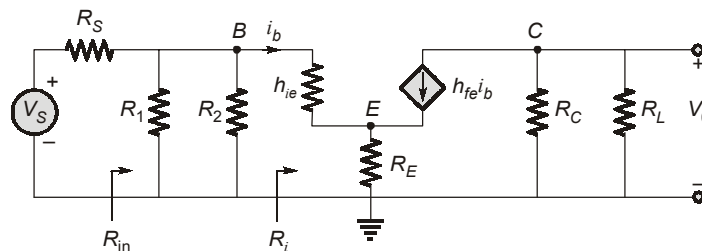

$$V_0 = -h_{fe} i_b (R_C \parallel R_L) = -h_{fe} i_b R'_L$$

$$R'_L = R_C \parallel R_L = 4 \text{ k}\Omega \parallel 2 \text{ k}\Omega = \frac{4}{3} \text{ k}\Omega$$

$$i_b = \frac{V_B}{R_i}$$

$$R_i = h_{ie} + (1 + h_{fe}) R_E = 1.9 \text{ k}\Omega + 10.1 \text{ k}\Omega = 12 \text{ k}\Omega \quad \because h_{fe} = 100, R_E = 100 \Omega$$

$$R_1 \parallel R_2 = 36 \text{ k}\Omega \parallel 18 \text{ k}\Omega = \frac{36 \text{ k}\Omega}{3} = 12 \text{ k}\Omega$$

$$R_{in} = R_i \parallel R_1 \parallel R_2 = 12 \text{ k}\Omega \parallel 12 \text{ k}\Omega = 6 \text{ k}\Omega$$

$$V_B = V_S \cdot \frac{R_{in}}{R_{in} + R_S} = V_S \cdot \frac{6}{6 + 2} = \frac{3V_S}{4}$$

$$i_b = \frac{V_B}{R_i} = \frac{3V_S}{4(12 \text{ k}\Omega)} = \frac{V_S}{16} \text{ mA}$$

$$V_0 = -h_{fe} i_b R'_L = -(100) \left(\frac{V_S}{16} \right) \left(\frac{4}{3} \right)$$

$$= -\frac{100}{12} V_S$$

$$\frac{V_0}{V_S} = -\frac{100}{12} = -8.33$$

15. (a)

$$I = I_s(e^{V/\eta V_T} - 1)$$

$$\frac{I}{(e^{V/\eta V_T} - 1)} = I_s$$

$$I = \frac{3 - 2.4}{100} = \frac{0.6}{100} = 6 \text{ mA}$$

$$V = \frac{2.4}{3} = 0.8 \text{ Volts}$$

$$I_s = \frac{6 \times 10^{-3}}{\left(e^{\frac{0.8}{0.025}} - 1\right)}$$

$$I_s = \frac{6 \times 10^{-3}}{(e^{32} - 1)}$$

$$\begin{aligned} I_s &= 7.59 \times 10^{-17} \text{ A} \approx 7.6 \times 10^{-17} \\ &= 0.076 \times 10^{-15} \text{ A} \\ &= 0.076 \text{ fA} \end{aligned}$$

16. (b)

$$\begin{aligned} \% \text{ regulation} &= \frac{V_{NL} - V_{FL}}{V_{FL}} \times 100 = \frac{30 - 25}{25} \times 100 \\ &= \frac{5}{25} \times 100 = 20\% \end{aligned}$$

17. (d)

Since $V_B = 0$ and $V_E = 0$,

No current flows in base, Hence transistor is in cut off.

$$\begin{aligned} V_0 &= \frac{R_L}{R_C + R_L} \times V_{CC} \\ &= \frac{10(5)}{15} = \frac{10}{3} = 3.33 \end{aligned}$$

Thus,

$$V_0 = 3.33 \text{ V}$$

18. (d)

$$\frac{I_{C1}}{I_{C2}} = \frac{I_s \exp\left(\frac{V_1}{V_T}\right)}{I_s \exp\left(\frac{V_2}{V_T}\right)}$$

$$\begin{aligned} \exp\left(\frac{V_1 - V_2}{V_T}\right) &= 10 \\ V_1 - V_2 &= V_T \ln(10) \approx 60 \text{ mV} \end{aligned}$$

19. (d)

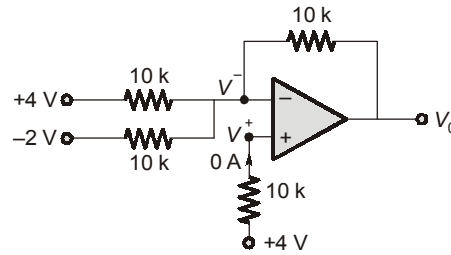

$$V^+ = V^- = 4 \text{ V}$$

By applying KCL at V^- ,

$$\frac{V^- - 4}{10 \text{ k}} + \frac{V^- - (-2)}{10 \text{ k}} + \frac{V^- - V_0}{10 \text{ k}} = 0$$

$$V_0 = 3 V^- - 4 + 2$$

$$V_0 = 3(4) - 4 + 2$$

$$V_0 = 12 - 4 + 2$$

$$V_0 = 10 \text{ V}$$

20. (c)

Small signal h -parameter model of the given amplifier circuit is,

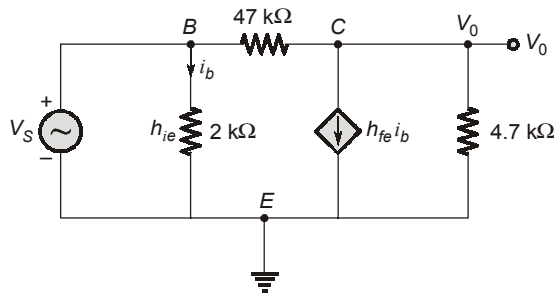

$$i_b = \frac{V_s}{h_{ie}} = \frac{V_s}{2 \text{ k}\Omega}$$

By writing KCL at node 'C',

$$\frac{V_s - V_0}{47 \text{ k}\Omega} = h_{fe} i_b + \frac{V_0}{4.7 \text{ k}\Omega}$$

$$= \frac{(100) V_s}{2 \text{ k}\Omega} + \frac{V_0}{4.7 \text{ k}\Omega}$$

$$V_s - V_0 = (50 \times 47) V_s + 10 V_0 = 2350 V_s + 10 V_0$$

$$11 V_0 = -2349 V_s$$

$$\frac{V_0}{V_s} = -\frac{2349}{11} = -213.54$$

21. (a)

$$I_D = \frac{\mu_n C_{ox}}{2} \left(\frac{W}{L} \right) (V_{gs} - V_{th})^2$$

$$\frac{\partial I_D}{\partial V_{gs}} = g_m = \frac{\mu_n C_{ox}}{2} \cdot \left(\frac{W}{L} \right) \cdot 2 (V_{gs} - V_{th})$$

$$\frac{I_D}{g_m} = \frac{(V_{gs} - V_t)}{2}$$

$$\Rightarrow \frac{2I_D}{g_m} = V_{gs} - V_t$$

$$I_D = \frac{k'_n \cdot W}{2 \cdot L} \left(\frac{2I_D}{g_m} \right)^2$$

$$1 \times 10^{-4} = \frac{50 \times 10^{-6}}{2} \left(\frac{W}{L} \right) \left(\frac{2 \times 1 \times 10^{-3} \times 10^{-1}}{1 \times 10^{-3}} \right)^2$$

$$\frac{W}{L} = \frac{10^{-4} \times 10^8 \times 2}{50 \times 4} = 100$$

22. (c)

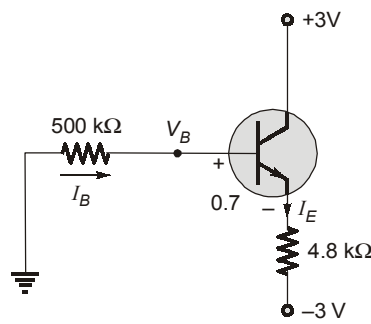

$$V_B = -I_B \cdot R_B$$

$$\frac{-1}{500 \times 10^3} = -I_B$$

$$\Rightarrow I_B = 2 \mu\text{A}$$

$$V_E + 3 = I_E (4.8 \text{ k}\Omega)$$

$$V_{BE} = 0.7 = V_B - V_E = -1 - V_E$$

$$1.7 = -V_E$$

$$\Rightarrow V_E = -1.7 \text{ V}$$

$$I_E = \frac{V_E + 3}{4.8} \text{ mA} = \frac{-1.7 + 3}{4.8} \text{ mA}$$

$$\Rightarrow I_E = \frac{13}{48} \text{ mA}$$

$$\frac{I_E}{I_B} = \beta + 1$$

$$\frac{13 \times 1000}{48 \times 2} = \beta + 1$$

$$\Rightarrow \beta = 134.42$$

23. (d)

$$R_i = r_\pi = \frac{\beta}{g_m}$$

$$g_m = \frac{I_C}{V_T}$$

Also,

$$I_C = \beta \cdot I_B$$

⇒

$$\beta = \frac{I_C}{I_B}$$

$$R_i = r_\pi = \frac{I_C}{I_B \cdot I_C} \cdot V_T = \frac{V_T}{I_B}$$

$$= \frac{25 \text{ mV}}{25 \mu\text{Amp}} = 1 \text{ k}\Omega$$

24. (b)

By drawing the small signal equivalent, we get

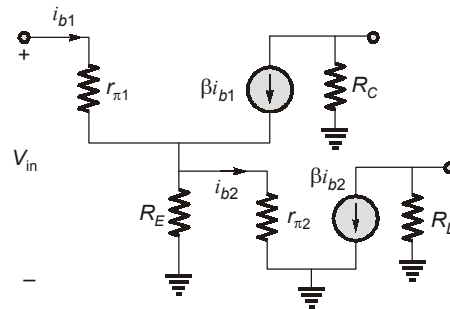

Thus, the above figure can be redrawn as

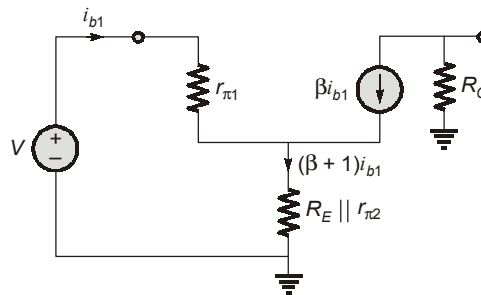

Applying KVL in loop-1

$$V = r_{\pi 1} i_{b1} + (\beta + 1) i_{b1} (R_E || r_{\pi 2})$$

$$\therefore \frac{V}{i_{b1}} = r_{\pi 1} + (\beta + 1) (R_E || r_{\pi 2})$$

By substituting the respective values,

$$R_{i_{in}} = \frac{V}{i_{b1}} = 51.5 \text{ k}\Omega$$

25. (c)

$$I = \frac{V_i}{R}$$

$$V_0 = -V_D$$

$$\frac{V_i}{R} = I_s(e^{V_D/V_T} - 1) = I_s(e^{-V_0/V_T} - 1)$$

$$\frac{V_i}{RI_s} + 1 = e^{-V_0/V_T}$$

$$V_0 = -V_T \ln\left(1 + \frac{V_i}{R \cdot I_s}\right) \text{ V} = -V_T \ln\left(1 + \frac{0.1}{10^5 \cdot 10^{-6}}\right) = -V_T \ln 2 \text{ V}$$

$$V_0 = -17.33 \text{ mV}$$

26. (a)

At the positive terminal $V_+ = -5 \text{ V}$. For $V_S > -5 \text{ V}$, D_1 is "ON" and D_2 is "OFF", due to virtual short $V_- = -5 \text{ Volt}$ and no current will flow in feedback resistor R .

So, $V_0 = -5 \text{ V}$

For $V_S < -5 \text{ Volt}$, D_1 is "OFF" and D_2 is "ON",

So, $V_0 = (-V_S - 10)$

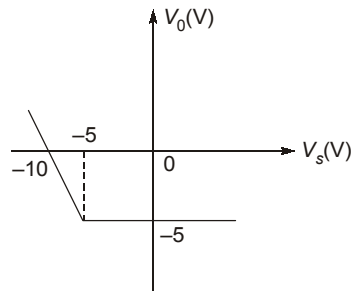

27. (c)

Reverse saturation current doubles for every 10°C rise in temperature.
The collector region is lightly doped than the emitter

28. (d)

By KCL $\frac{0 - V_i}{R} + \frac{0 - V_1}{R} = 0$

$$-V_i = V_1$$

$$\Rightarrow \frac{V_1}{R} + \frac{V_1 - V_2}{R} + \frac{V_1}{R} = 0$$

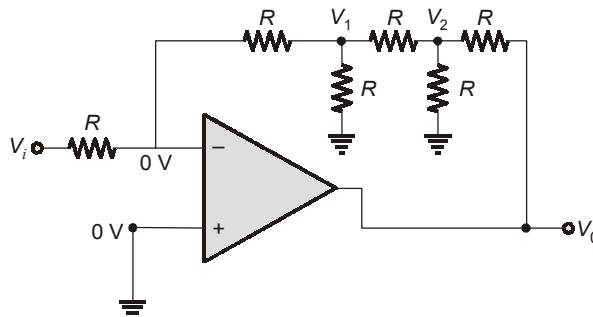

$$\frac{3V_1}{R} = \frac{V_2}{R}$$

$$V_2 = 3V_1$$

$$\Rightarrow \frac{V_2}{R} + \frac{V_2 - V_1}{R} + \frac{V_2 - V_0}{R} = 0$$

$$\begin{aligned}
 3V_2 - V_1 &= V_0 \\
 8V_1 &= V_0 & \therefore V_2 &= 3V_1 \\
 8(-V_i) &= V_0 & \therefore V_1 &= -V_i \\
 \frac{V_0}{V_i} &= -8
 \end{aligned}$$

29. (b)

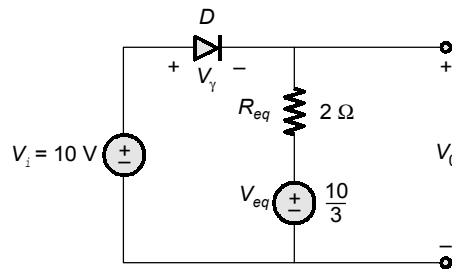

$$V_{eq} = \frac{-\frac{10}{6} + \frac{10}{3}}{\frac{1}{6} + \frac{1}{3}} = \frac{10 \times \frac{3}{18}}{\frac{9}{18}} = \frac{10 \times 3}{9} = \frac{10}{3} \text{ volts.}$$

$$R_{eq} = \frac{6 \times 3}{9} = 2 \Omega. \quad V_i = 10;$$

as $V_i > V_{eq}$, D is ON and the voltage across the diode will be V_Y .

$$V_0 = -V_Y + V_i = -0.7 \text{ V} + 10 \text{ V} = 9.3 \text{ V}$$

30. (c)

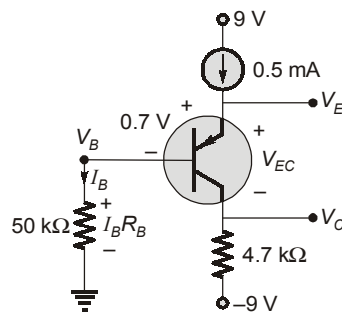

$$I_C = \frac{\beta}{\beta + 1} (I_E) = \frac{49(0.5)}{50} \text{ mA} = 0.49 \text{ mA}$$

$$I_E = I_C + I_B$$

$$I_B = I_E - I_C = 0.50 - 0.49$$

$$I_B = 0.01 \text{ mA}$$

$$V_E = I_B R_B + V_{EB} = 0.7 + (0.01 \times 50)$$

$$V_E = 1.2 \text{ V}$$

$$V_C = I_C R_C - 9 \text{ V} = (0.49)(4.7) - 9 = -6.697 \text{ V}$$

$$V_{EC} = 1.2 \text{ V} - (-6.697 \text{ V}) = 7.897 \text{ V}$$

$$P_Q \approx I_C V_{EC} = (0.49)(7.897) \text{ mW} = 3.87 \text{ mW}$$

