

CLASS TEST

S.No. : 02 IG_CE_130619

Engineering Mechanics



MADE EASY

India's Best Institute for IES, GATE & PSUs

Delhi | Noida | Bhopal | Hyderabad | Jaipur | Lucknow | Indore | Pune | Bhubaneswar | Kolkata | Patna

Web: www.madeeasy.in | E-mail: info@madeeasy.in | Ph: 011-45124612

CLASS TEST 2019-2020

CIVIL ENGINEERING

Date of Test : 13/06/2019

ANSWER KEY ► Engineering Mechanics

1. (b)	7. (c)	13. (c)	19. (c)	25. (a)
2. (c)	8. (a)	14. (c)	20. (d)	26. (a)
3. (a)	9. (d)	15. (c)	21. (a)	27. (d)
4. (a)	10. (c)	16. (b)	22. (c)	28. (c)
5. (c)	11. (d)	17. (c)	23. (b)	29. (a)
6. (c)	12. (a)	18. (d)	24. (a)	30. (c)

DETAILED EXPLANATIONS

1. (b)

$$e = \frac{\text{Velocity of separation}}{\text{Velocity of approach}}$$

For perfectly elastic body, $e = 1$ and no dissipation of energy occurs.

2. (c)

$$\theta = \omega_0 t + \frac{1}{2} \alpha t^2$$

$$\omega_0 = 0$$

$$\theta = \frac{1}{2} \times 2 \times 10^2 = 100 \text{ rad}$$

$$\therefore \text{Number of revolutions} = \frac{100}{2\pi} = 15.92$$

3. (a)

During inelastic collision, only linear momentum is conserved.

4. (a)

Change in the stored energy of rubber band = $F dx$

$$\Rightarrow dE = 300x^2 dx$$

$$\text{Integrating, } \int_0^E dE = \int_0^{0.1} 300x^2 dx$$

$$\Rightarrow E = 300 \times \frac{x^3}{3} \Big|_0^{0.1} = 0.1 \text{ Joule}$$

5. (c)

$$I = mk^2 = 50(0.180)^2 = 1.62 \text{ kg.m}^2$$

$$M = I\alpha$$

$$3.5 = (1.62) \alpha$$

$$\Rightarrow \alpha = 2.1605 \text{ rad/s}^2 \text{ (deceleration)}$$

$$\omega_0 = \frac{2\pi N}{60} = \frac{2\pi(3600)}{60} = 120\pi \text{ rad/s}$$

$$\omega^2 = \omega_0^2 + 2\alpha\theta \quad \text{or} \quad 0 = (120\pi)^2 - 2 \times 2.1605 \times \theta$$

$$\therefore \theta = 32.891 \times 10^3 \text{ rad}$$

$$\text{Number of revolutions} = \frac{\theta}{2\pi} = \frac{32.891 \times 10^3}{2 \times 3.14} = 5234.77$$

6. (c)

$$\text{Kinetic energy, } KE = \frac{1}{2}I\omega^2$$

$$I = \frac{mr^2}{2} = \frac{20 \times (0.2)^2}{2} = 0.4 \text{ kgm}^2$$

$$\omega = \frac{2\pi N}{60} = \frac{2 \times \pi \times 600}{60} = 62.83 \text{ rad/sec}$$

$$\therefore KE = \frac{1}{2} \times 0.4 \times (62.83)^2 \simeq 790 \text{ Joules}$$

7. (c)

$$F = 100\sqrt{2^2 + 3^2 + (3.464)^2} \simeq 500 \text{ N}$$

$$\cos \alpha = \frac{200}{500} = 0.4$$

$$\alpha = \cos^{-1} 0.4 = 66.42^\circ$$

8. (a)

$$P = \frac{W}{R} \cdot \mu$$

where, P = Rolling resistance, R = Radius of wheel, W = Weight of freight car
 Coefficient of rolling resistance,

$$\mu = \frac{PR}{W} = \frac{30 \times 750}{1000000} = 0.0225 \text{ mm} = 22.5 \times 10^{-3} \text{ mm}$$

9. (d)

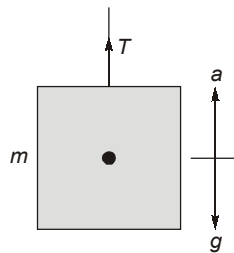

$$T = m(a + g) = 400(3 + 10) = 5200 \text{ N}$$

10. (c)

Let, S be the distance by which a pile will move under a single blow of hammer.

Work done by hammer = Work done by the ground resistance

$$\frac{1}{2}(12 + 4)V^2 = 200 \times S$$

$$\Rightarrow 8 \times 4^2 = 200 \times S$$

$$\Rightarrow 128 = 200 \times S$$

$$\Rightarrow S = 0.64 \text{ m}$$

12. (a)

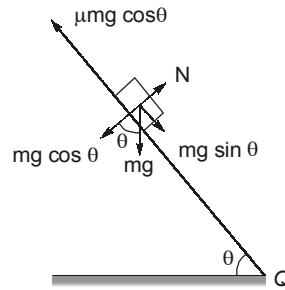

From Newton's second law

$$mg \sin \theta - \mu mg \cos \theta = ma$$

$$\therefore a = g(\sin \theta - \mu \cos \theta)$$

$$\Rightarrow a = g \cos \theta (\tan \theta - \mu)$$

Now, $s = ut + \frac{1}{2}at^2$

$$\Rightarrow s = 0 + \frac{1}{2}g \cos \theta (\tan \theta - \mu) \cdot t^2$$

$$\therefore t = \sqrt{\frac{2s}{g \cos \theta (\tan \theta - \mu)}}$$

13. (c)

$$\omega = 12 + 9t - 3t^2$$

$$\frac{d\omega}{dt} = 9 - 6t = 0$$

$$\Rightarrow t = 1.5 \text{ s}$$

$$\frac{d^2\omega}{dt^2} = -6 < 0$$

Hence, at $t = 1.5$ sec maximum value of angular velocity will occur

$$\begin{aligned} \therefore \omega_{\max} &= 12 + 9 \times 1.5 - 3 \times 1.5^2 \\ &= 12 + 13.5 - 6.75 \\ &= 18.75 \text{ rad/s} \end{aligned}$$

14. (c)

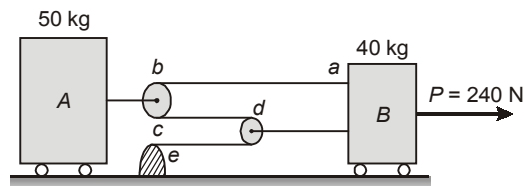

As given, acceleration $a_A = 1.5 a_B$

For block B:

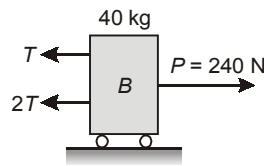

$$\Sigma F = \text{Mass} \times \text{Acceleration}$$

$$240 - 3T = 40 a_B \quad \dots(i)$$

For block A:

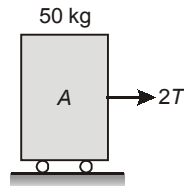

$$\Rightarrow \Sigma F = \text{Mass} \times \text{Acceleration}$$

$$\Rightarrow 2T = 50 a_A \quad \dots(ii)$$

$$\Rightarrow 2T = 50 \times 1.5 a_B$$

$$\Rightarrow 2T = 75 a_B \quad \dots(iii)$$

Using equation (i) and (iii), we get

$$\Rightarrow 240 - 1.5 \times 75 a_B = 40 a_B$$

$$\Rightarrow 152.5 a_B = 240$$

$$\therefore a_B = 1.57 \text{ m/s}^2$$

15. (c)

Let the shortest distance between ships will occur at time thereafter the ship A passes point O.

The distance of ship A from O = $20 t$

The distance of ship B from O = $20 (2 - t)$

The distance between ships

$$D = \sqrt{(20t)^2 + \{20(2 - t)\}^2}$$

For shortest distance

$$\frac{dD}{dt} = 0 \quad \text{or} \quad \frac{d(D^2)}{dt} = 0$$

$$2 \times 20t - 20(2 - t) \times 2 = 0$$

$$t = 1 \text{ hrs}$$

$$\text{Shortest distance} = 20\sqrt{2} \text{ km}$$

16. (b)

Free body diagram of A:

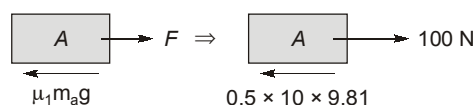

Writing equation of motion for A.

$$100 - 0.5 \times 10 \times 9.81 = 10a$$

$$\Rightarrow a = 5.095 \text{ m/s}^2$$

Free body diagram of B:

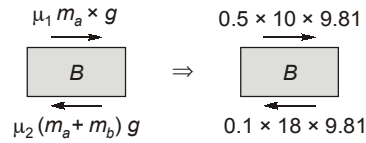

Writing equation of motion for B.

$$49.05 - 17.658 = 8a$$

$$\Rightarrow a = 3.924 \text{ m/s}^2$$

After 0.1s,

$$V_A = U_a + a_a t$$

$$V_A = 0 + 5.095 \times 0.1$$

$$V_A = 0.5095 \text{ m/s}$$

Similarly,

$$V_B = 0 + 3.924 \times 0.1$$

$$V_B = 0.3924 \text{ m/s}$$

$$\therefore \text{Relative velocity of A w.r.t. B} = V_A - V_B \\ = 0.5095 - 0.3924 \approx 0.12 \text{ m/s}$$

17. (c)

$$5g(2.1) = \frac{1}{2} \times 5 \times V^2 + \frac{1}{2} k \delta^2 \quad [\because k = 10000 \text{ N/m}]$$

$$\Rightarrow 10.5g = 2.5V^2 + \frac{1}{2} \times 10000 \times (0.1)^2$$

$$\Rightarrow 10.5 \times 9.81 = 2.5V^2 + 50$$

$$\Rightarrow V^2 = 21.202$$

$$\therefore V = 4.6 \text{ m/s}$$

18. (d)

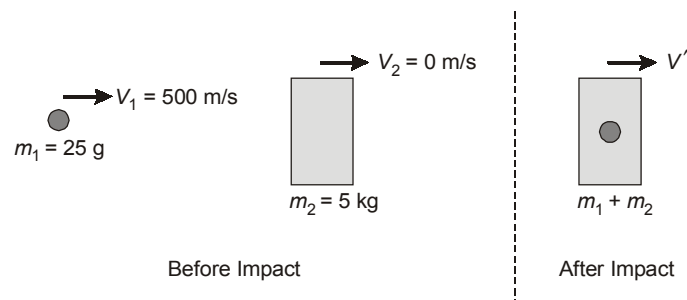

$$V' = \frac{0.025 \times 500}{5 + 0.025} = \frac{12.5}{5.025} = 2.488 \text{ m/s}$$

Change in kinetic energy,

$$\Delta KE = \frac{1}{2} \times 0.025 \times 500^2 - \frac{1}{2} \times 5.025 \times 2.488^2 \\ = 3125 - 15.55 = 3109.45 \text{ J}$$

$$\text{Percentage of energy lost} = \frac{3109.45}{3125} \times 100 = 99.5\%$$

19. (c)

Coefficient of restitution,

$$e = -\frac{\Delta V}{\Delta u} = -\frac{v_2 - v_1}{u_2 - u_1}$$

here,

$$u_2 = 0,$$

$$v_2 = 0$$

$$e = \frac{v_1}{u_1}$$

$$v^2 - u^2 = 2ah$$

when ball is dropped from height,

$$u = 0$$

Let final velocity is u_1

$$u_1^2 = 2ah_1$$

$$v_1^2 = 2ah_2$$

$$e^2 = \left(\frac{v_1}{u_1}\right)^2 = \frac{h_2}{h_1}$$

 \therefore

$$h_2 = h_1 \times e^2 = 0.36 \text{ m}$$

20. (d)

Considering both bars together as a free body, we see that they are in equilibrium under the action of three parallel forces i.e. weights W and $2W$ and the vertical reaction exerted by the string AD .

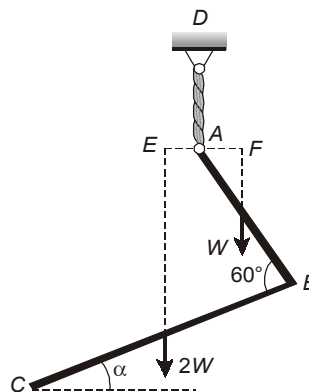

For equilibrium condition,

$$\Sigma M_A = 0$$

$$\Rightarrow 2W \times AE - W \times AF = 0$$

$$\therefore AF = 2AE \quad \dots(i)$$

Now, from the geometry of the system,

$$AF = \frac{L}{2} \cos(60^\circ - \alpha) \quad \dots(ii)$$

and $AE = (L \cos \alpha - L \cos (60^\circ - \alpha))$... (iii)

From equations (i), (ii) and (iii), we get

$$\frac{L}{2} \cos(60^\circ - \alpha) = 2(L \cos \alpha - L \cos (60^\circ - \alpha))$$

$$\tan \alpha = \frac{\sqrt{3}}{5}$$

$$\alpha = 19.11^\circ$$

21. (a)

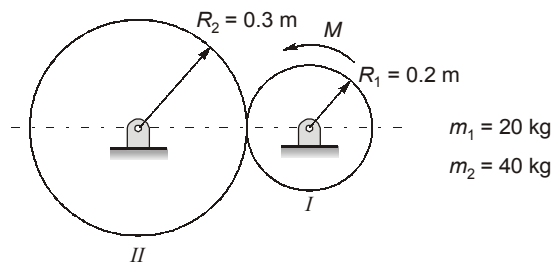

$$\text{Moment of inertia, } I_2 = \frac{m_1 R_1^2}{2} = \frac{20 \times 0.2^2}{2} = 0.4 \text{ kgm}^2$$

$$I_2 = \frac{m_2 R_2^2}{2} = \frac{40 \times 0.3^2}{2} = 1.8 \text{ kgm}^2$$

A force of friction F acts between disc I and II which drives disc II .

$$F \times R_2 = I_2 \alpha_2 \quad \dots(1)$$

$$R_1 \alpha_1 = R_2 \alpha_2$$

$$\Rightarrow 0.2 \times 8.33 = 0.3 \times \alpha_2$$

$$\alpha_2 = 5.55 \text{ m/s}^2$$

Put α_2 value in (1)

We get $F = 33.32 \text{ N}$

$$M - FR_1 = I_1 \alpha_1$$

$$\Rightarrow M - 33.32 \times 0.2 = 0.4 \times 8.33$$

$$M = 9.996 \simeq 10 \text{ Nm}$$

22. (c)

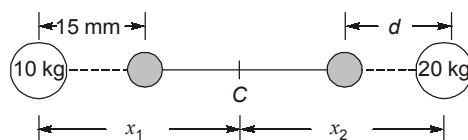

To keep centre of mass at C

$$m_1 x_1 = m_2 x_2 \quad \rightarrow \quad (\text{Let } 10 \text{ kg} = m_1, 20 \text{ kg} = m_2)$$

and

$$m_1(x_1 - 15) = m_2(x_2 - d)$$

$$15 m_1 = m_2 d$$

$$d = \frac{15 \times 10}{20} = 7.5 \text{ mm}$$

23. (b)

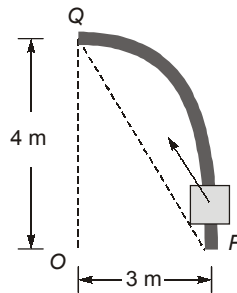

$$\begin{aligned} \text{Change in Kinetic Energy} &= \text{Total work done} = W_{18} + W_{mg} \\ &= F.S. - mg \times s' \\ &= 18 \times PQ - 1 \times 10 \times OQ \\ &= 18 \times 5 - 10 \times 4 \\ &= 50 \text{ J} \end{aligned}$$

$$\left[PQ = \sqrt{4^2 + 3^2} = 5 \text{ m} \right]$$

Change in kinetic energy is positive hence increase in kinetic energy is 50 J.

24. (a)

Since no external torque has acted, angular momentum will be conserved.

Applying conservation of angular momentum,

$$\therefore I\omega = I'\omega'$$

$$MR^2 \times \omega = (MR^2 + 2mR^2)\omega'$$

$$5 \times (0.2)^2 \times 10 = [5 \times (0.2)^2 + 2 \times 0.5 \times (0.2)^2]\omega'$$

$$\Rightarrow \omega' = 8.333 \text{ rad s}^{-1}$$

25. (a)

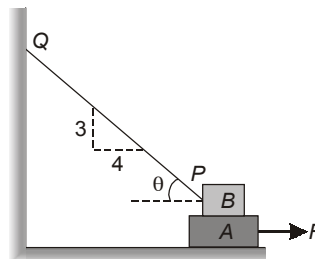

$$\tan \theta = \frac{3}{4}$$

The free body diagrams of the blocks are shown below.

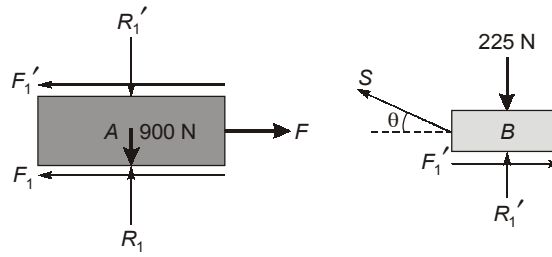

$$F_1 = \mu R_1 \text{ and } F_1' = \mu R_1' \quad \dots(i)$$

From equilibrium of block A,

$$F - F_1 - F_1' = 0 \quad \dots(ii)$$

and $R_1 - W_1 - R_1' = 0 \quad \dots(iii)$

$$\Rightarrow R_1 = \frac{F_1}{\mu} = W_1 + \frac{F_1'}{\mu} \quad \dots(iv)$$

From the equilibrium of block B,

$$F_1' - S \cos \theta = 0 \quad \dots(v)$$

and $R_1' + S \sin \theta - W_2 = 0 \quad \dots(vi)$

$$\Rightarrow F_1' = \frac{W_2}{1/\mu + \tan \theta} \quad \dots(vii)$$

From equations (ii), (iv) and (vii), we get

$$F = \mu W_1 + \frac{2W_2}{\frac{1}{\mu} + \tan \theta} = 0.3 \times 900 + \frac{2 \times 225}{\frac{1}{0.3} + \frac{3}{4}} = 380.2 \text{ N}$$

26. (a)

$$x = 10 \sin 2t + 15 \cos 2t + 100$$

$$v = \frac{dx}{dt} = 20 \cos 2t - 30 \sin 2t$$

$$a = \frac{dv}{dt} = -40 \sin 2t - 60 \cos 2t \quad \dots(i)$$

For a_{\max} , $\frac{da}{dt} = 0$

$$\Rightarrow -80 \cos 2t + 120 \sin 2t = 0$$

$$\tan 2t = \frac{2}{3}$$

$$\Rightarrow 2t = 33.69$$

Now using equation (i), we get

$$a_{\max} = -40 \sin (33.69) - 60 \times \cos (33.69) = -72.11 \text{ mm/s}^2$$

27. (d)

$$I = -2\hat{i} - \hat{j} + \hat{k}$$

$$r = 2\hat{i} - 3\hat{j} + \hat{k}$$

$$\text{Angular momentum} = H = r \times I$$

$$= (2\hat{i} - 3\hat{j} + \hat{k}) \times (-2\hat{i} - \hat{j} + \hat{k}) = \begin{vmatrix} \hat{i} & \hat{j} & \hat{k} \\ 2 & -3 & 1 \\ -2 & -1 & 1 \end{vmatrix}$$

$$= \hat{i}(-3+2) - \hat{j}(2+4) + \hat{k}(-2-6)$$

$$= \hat{i}(-1) - 6\hat{j} - 8\hat{k} = -\hat{i} - 6\hat{j} - 8\hat{k}$$

$$|H| = \sqrt{1^2 + 6^2 + 8^2} = 10.01 \text{ kg m}^2/\text{s} \approx 10 \text{ kg m}^2/\text{s}$$

28. (c)

Free body diagram of beam AB,

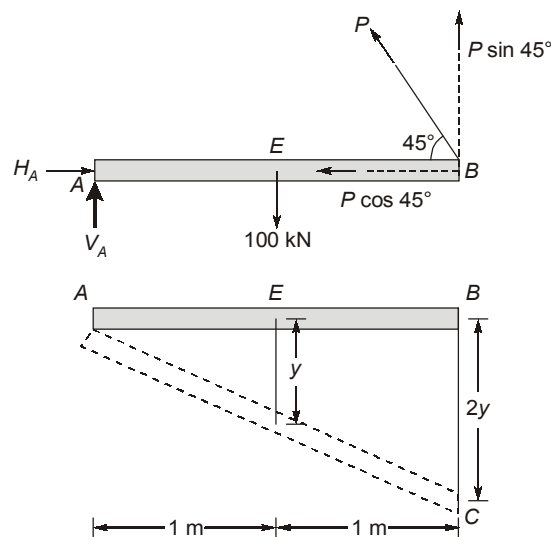

Now using the principle of virtual work done, if C.G. of beam AB shifts by an amount 'y' then end B must shift by '2y' (using similar triangles).

$$\therefore 100 \times y - P \sin 45^\circ \times 2y = 0$$

$$\Rightarrow P = 70.71 \text{ kN}$$

29. (a)

Considering velocities to the right as positive,

$$\text{The initial momentum of the system} = \frac{W+w}{g} v_0$$

$$\text{The final momentum of the car} = \frac{W}{g} (v_0 + \Delta v)$$

The final momentum of the man = $\frac{w}{g}(v_0 + \Delta v - u)$

Since no external forces act on the system, the law of conservation of momentum gives,

$$\frac{W+w}{g}v_0 = \frac{W}{g}(v_0 + \Delta v) + \frac{w}{g}(v_0 + \Delta v - u)$$

$$\Rightarrow W\Delta v - wu + w\Delta v = 0$$

$$\therefore \Delta v = \frac{wu}{W+w}$$

30. (c)

$$T \sin\theta + R_y = mg$$

$$T \cos\theta = R_x$$

Now, $\tan\theta = \frac{125}{275}$

$$\theta = 24.44^\circ$$

Taking moments about A,

$$l \times T \sin\theta = l \times mg$$

$$\Rightarrow T = \frac{35 \times 9.81}{\sin 24.44^\circ} = 829.87 \text{ N}$$

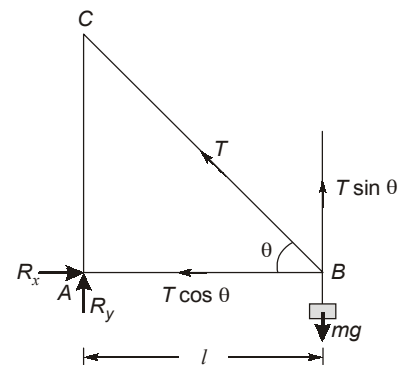

■■■■