

CLASS TEST

S.No. : 01 SK_CE+ME_090619

Engineering Mechanics



MADE EASY

India's Best Institute for IES, GATE & PSUs

Delhi | Noida | Bhopal | Hyderabad | Jaipur | Lucknow | Indore | Pune | Bhubaneswar | Kolkata | Patna

Web: www.madeeasy.in | E-mail: info@madeeasy.in | Ph: 011-45124612

CLASS TEST 2019-2020

CIVIL | MECHANICAL

Date of Test : 09/06/2019

ANSWER KEY ► Engineering Mechanics

1. (a)	7. (b)	13. (d)	19. (c)	25. (c)
2. (b)	8. (c)	14. (b)	20. (c)	26. (c)
3. (b)	9. (b)	15. (a)	21. (c)	27. (d)
4. (a)	10. (a)	16. (c)	22. (b)	28. (d)
5. (b)	11. (b)	17. (a)	23. (b)	29. (c)
6. (c)	12. (c)	18. (d)	24. (c)	30. (b)

DETAILED EXPLANATIONS

1. (a)

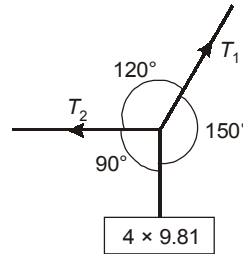

As the body is in equilibrium, using Lami's theorem

$$\begin{aligned} \therefore \frac{T_1}{\sin 90^\circ} &= \frac{4 \times 9.81}{\sin(120^\circ)} \\ \therefore T_1 &= 45.310 \text{ N} \\ \frac{T_2}{\sin 150^\circ} &= \frac{4 \times 9.81}{\sin 120^\circ} \\ \Rightarrow T_2 &= 22.65 \text{ N} \end{aligned}$$

2. (b)

For a statically determinate frame,

We know, $m = 2j - 3$

Where, $m =$ Number of members

$j =$ Number of joints

On comparing with, $y = mx + c$

$c = -3; m = \tan \theta = 2$

$\therefore \theta = 63.43^\circ$

3. (b)

Applying Lami's Theorem,

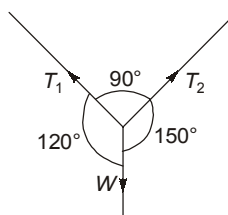

$$\begin{aligned} \frac{T_1}{\sin 150^\circ} &= \frac{T_2}{\sin 120^\circ} = \frac{W}{\sin 90^\circ} \\ \therefore \frac{T_1}{T_2} &= \frac{\sin 150^\circ}{\sin 120^\circ} \\ \therefore \frac{T_1}{T_2} &= 0.577 \end{aligned}$$

4. (a)

Let V' and V'' be the speed of Y and X respectively after collision.

Applying conservation of momentum,

$$mV = 2mV' - mV'' \quad \dots(a)$$

Applying conservation of kinetic energy,

$$\frac{1}{2}mV^2 = \frac{1}{2} \times 2mV'^2 + \frac{1}{2} \times mV''^2 \quad \dots(b)$$

Solving (a) and (b),

$$V' = 2V''$$

$$V = 3V''$$

$$\Rightarrow V'' = \frac{V}{3}$$

$$\Rightarrow V' = \frac{2V}{3}$$

5. (b)

Drawing free diagram of blocks, we have,

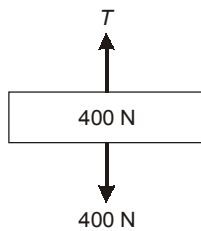

$$T = 400 \text{ N}$$

∴

$$T + R = 1000$$

$$400 + R = 1000$$

$$R = 600 \text{ N}$$

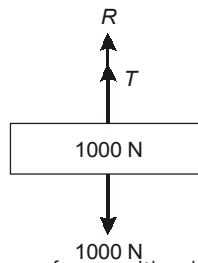

This is the reaction from the ground and it is the same force with which the 1000 N block press against the floor.

6. (c)

$$\omega = (12 + 9t - 3t^2)$$

$$\frac{d\omega}{dt} = 9 - 6t = 0, t = 1.5 \text{ s}$$

$$\begin{aligned} \omega_{\max} &= 12 + 9 \times 1.5 - 3 \times 1.5^2 \\ &= 12 + 13.5 - 6.75 \\ &= 18.75 \text{ rad/s} \end{aligned}$$

7. (b)

$$R_2 \cos 45^\circ = R_1$$

$$R_2 \sin 45^\circ = W$$

$$\Rightarrow R_2 = W\sqrt{2}$$

$$\therefore R_1 = W\sqrt{2} \times \frac{1}{\sqrt{2}} = W$$

$$W = 50 \text{ N}$$

$$\therefore R_1 = 50 \text{ N}$$

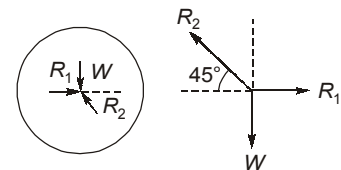

8. (c)

Normal reaction, $N = 200 - P \sin 30^\circ = 200 - 100 \times 0.5 = 150 \text{ N}$

Frictional force, $F = \mu N = 0.3 \times 150 = 45 \text{ N}$

9. (b)

The velocity of point Q is zero, as the point Q is in contact with the surface.

10. (a)

Torque,

$$T = mg \times \frac{L}{2}$$

$$I_0 = \frac{mL^2}{3}$$

$$\alpha = \frac{T}{I_0} = \frac{mgL}{2} \times \frac{3}{mL^2} = \frac{1.5g}{L}$$

11. (b)

Taking joint A,

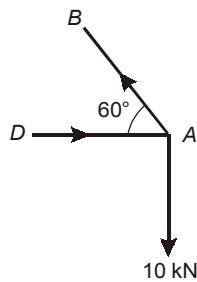

Resolving forces, as the trusses in equilibrium,

$$P_{AB} \times \sin 60^\circ = 10$$

$$\Rightarrow P_{AB} = \frac{10}{\sin 60^\circ} = 11.5 \text{ kN (Tensile)}$$

12. (c)

Consider the free body diagram of joint A with the direction of forces assumed as shown.

Joint A,

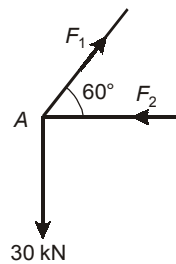

Equations of equilibrium are:

$$\sum F_x = 0$$

$$F_1 \cos 60^\circ - F_2 = 0$$

Also,

$$\sum F_y = 0$$

$$F_1 \sin 60^\circ - 30 = 0$$

\therefore

$$F_1 = 34.64 \text{ kN}$$

$$F_2 = F_1 \cos 60^\circ = 34.64 \times 0.5 = 17.32 \text{ kN (compression)}$$

Joint F,

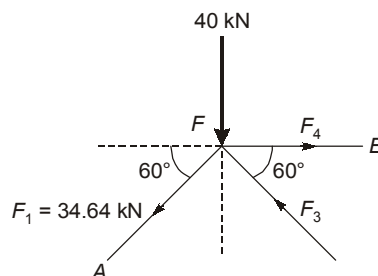

$$\begin{aligned} \Sigma F_x &= 0 \\ F_4 - F_3 \cos 60^\circ - 34.64 \cos 60^\circ &= 0 \\ F_4 &= 0.5 F_3 + 17.32 \\ \Sigma F_y &= 0 \\ F_3 \sin 60^\circ - 34.64 \sin 60^\circ - 40 &= 0 \\ F_3 &= 80.81 \text{ kN} \\ F_4 &= 0.5 \times 80.81 + 17.32 \\ &= 57.72 \text{ (tension)} \\ \therefore \frac{F_4}{F_2} &= 3.332 \end{aligned}$$

13. (d)

$$\begin{aligned} \omega_0 &= 8000 \text{ rpm} = 837.33 \text{ rad/s} \\ t &= 5 \text{ min} = 300 \text{ s} \\ \theta &= \omega_0 t + \frac{1}{2} \alpha t^2 \\ \alpha &= \frac{\omega - \omega_0}{t} = -\frac{837.33}{300} = -2.791 \text{ rad/s}^2 \\ \theta &= 837.33 \times 300 - 0.5 \times 2.791 \times (300)^2 = 125604 \text{ rad} \end{aligned}$$

$$\therefore \text{Number of revolutions} = \frac{\theta}{2\pi} = 19990.49 \simeq 19991$$

14. (b)

To stop the tiger in his track, momentum of the tiger should be balanced by momentum of bullets.

If the number of bullets are n

$$\text{Then } MV = n(mv)$$

$$\Rightarrow 60 \times 10 = n \times \frac{50}{1000} \times 150$$

$$\Rightarrow n = 80 \text{ bullets}$$

15. (a)

Let ω be the angular velocity of disc

$$\begin{aligned} V_Q &= r\omega \\ V_P &= r\omega + r\omega = 2r\omega \end{aligned}$$

$$\therefore \frac{V_P}{V_Q} = 2$$

16. (c)

From method of section

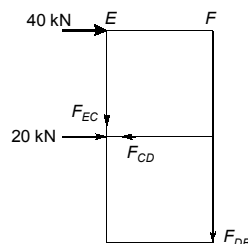

Considering equilibrium for horizontal

$$\Sigma \vec{F}_H = 0$$

$$40 - F_{CD} = 0$$

$$\therefore F_{CD} = 40 \text{ kN (Tensile)}$$

17. (a)

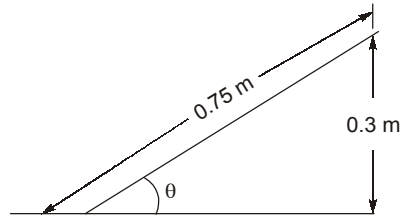

$$\text{Coefficient of friction} = \mu$$

$$\mu = \tan \theta$$

$$\text{From figure, } \sin \theta = \frac{0.3}{0.75} = 0.4$$

$$\Rightarrow \theta = \sin^{-1}(0.4)$$

$$\therefore \theta = 23.57^\circ$$

$$\mu = \tan \theta$$

$$\tan 23.57^\circ = 0.436$$

or

$$mg \sin \theta = (f_s)_{\max} = \mu N$$

$$N = mg \cos \theta$$

$$\tan \theta = \mu$$

$$\mu = 0.436$$

18. (d)

For no tipping or prevent overturning

$$Ph < \frac{Wb}{2}$$

where $W \rightarrow$ weight of blockand $b \rightarrow$ width of block

$$h < \frac{Wb}{2P} \quad \dots(1)$$

and for slipping without tipping

$$P > f(\text{force of friction})$$

$$P > \mu W \quad \dots(2)$$

From (1) and (2)

$$h < \frac{b}{2\mu}$$

$$\therefore h < \frac{60}{0.6}$$

$$\therefore h < 100 \text{ mm}$$

Option (d) is correct.

19. (c)

$$I = 2000 \times 0.25^2 = 125 \text{ kg-m}^2$$

for retardation, $\omega = \omega_0 + \alpha t$

$$\omega = 0$$

$$\omega_0 = \frac{2\pi N}{60} = \frac{2\pi \times 3000}{60}$$

$$t = 10 \text{ min} = 600 \text{ sec}$$

$$\alpha = \frac{2\pi \times 3000}{60 \times 600} = 0.5236 \text{ rad/s}$$

So, average frictional torque,

$$I\alpha = 65.44 \text{ Nm}$$

20. (c)

$$\begin{aligned} \text{Resistance} &= mg + W = 200 \times 9.81 + 100 \\ &= 2062 \text{ N} \end{aligned}$$

$$\therefore a = \frac{2062}{200}$$

$$a = 10.31 \text{ m/s}^2$$

$$\frac{v^2}{2a} = S = \frac{4^2}{2 \times 10.31} = 0.776 \text{ m}$$

21. (c)

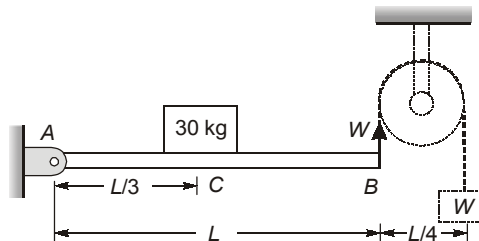

W is the tension in the string.

Taking moments from end A

$$W \times L = 30 \times 9.81 \times L/3$$

$$W = 98.1 \text{ N}$$

22. (b)

$$a = -t$$

$$dV = -t dt$$

$$V = -\frac{t^2}{2} + C_1$$

$$7.5 = 0 + C_1$$

$$\therefore C_1 = 7.5$$

$$V = -\frac{t^2}{2} + 7.5$$

$$V_{at\ 3s} = \frac{-3^2}{2} + 7.5 = 3\text{ m/s}$$

$$V_{at\ 3s} = 3\text{ m/s}$$

23. (b)

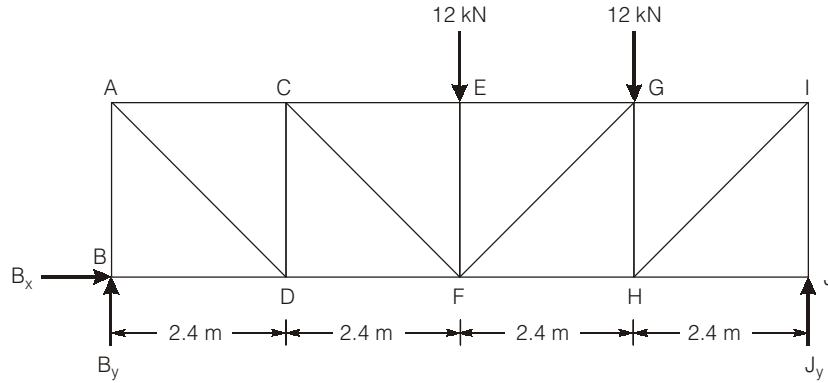

$$\sum M_J = 0,$$

$$12 \times 4.8 + 12 \times 2.4 = B_y \times 9.6$$

$$B_y = 9\text{ kN}$$

$$\sum F_y = 0,$$

$$B_y + J_y = 24\text{ kN}, \quad J_y = 15\text{ kN}$$

$$F_{CD} + 9 = 0$$

$$F_{CD} = -9\text{ kN}$$

$$\sum M_C = 0,$$

$$-9 \times 2.4 + F_{DF} \times 1.8 = 0$$

$$F_{DF} = \frac{9 \times 2.4}{1.8} = 12\text{ kN}$$

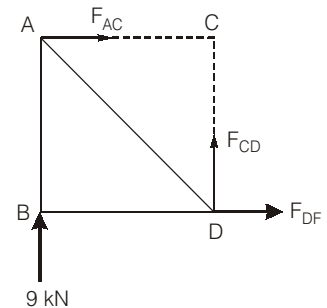

24. (c)

$$F_{BC} = F_{CD} = F_{DE} = F_{EF} = 0$$

25. (c)

In xy direction

$$-T \sin 20^\circ i + T \cos 20^\circ j + Ri - 300j = 0$$

$$(R - T \sin 20^\circ)i + (0.947 - 300)j = 0$$

then $R - T \sin 20^\circ = 0$

$$0.94 T - 300 = 0$$

$$(\text{Tension}) T = \frac{300}{0.94} = 319.15\text{ N}$$

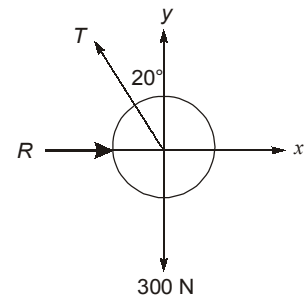

26. (c)

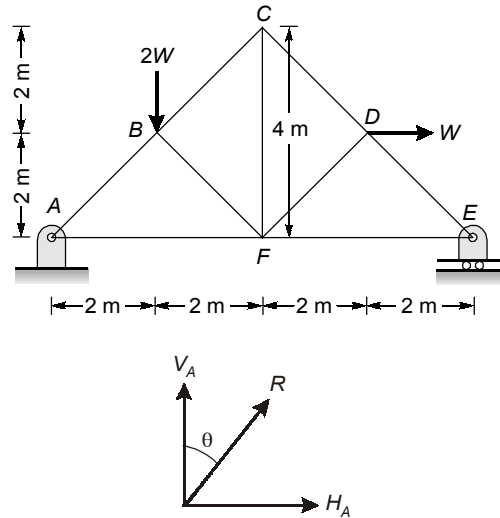

For the roller support at E, there will no horizontal reaction.

Taking moments about A,

$$V_E \times 8 = 2W \times 2 + W \times 2$$

$$V_E = 0.75W$$

$$\therefore V_A = 2W - 0.75W = 1.25W$$

$$\therefore \text{Also, } H_A = W \quad [\text{towards left}]$$

$$\therefore \tan \theta = \frac{H_A}{V_A} = \frac{W}{1.25W} = 0.8$$

$$\Rightarrow \theta = \tan^{-1}(0.8) = 38.65$$

27. (d)

$$\begin{aligned} \text{Kinetic Energy of the block} &= \text{Work done on it} - \text{Work done against gravity} \\ &= F.S. - mg \times s' = 18 \times PQ - 1 \times 10 \times OQ \\ &= 18 \times 5 - 10 \times 4 \end{aligned}$$

$$[PQ = \sqrt{4^2 + 3^2} = 5]$$

$$\text{Kinetic energy of the block} = 50 \text{ J}$$

28. (d)

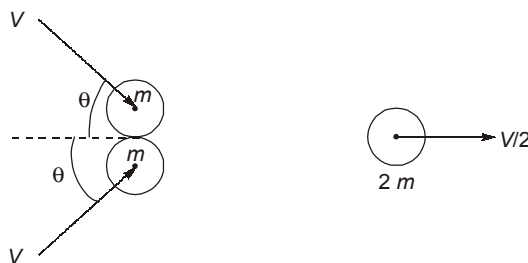

Momentum will be conserved in x-direction,

Let θ be the angle of velocity of each mass from x-direction as shown in figure.

$$mV \cos \theta + mV \cos \theta = 2m \times \frac{V}{2}$$

$$2 \cos \theta = 1$$

$$\cos\theta = \frac{1}{2}$$

$$\theta = 60^\circ$$

So the total angle = $2\theta = 120^\circ$

29. (c)

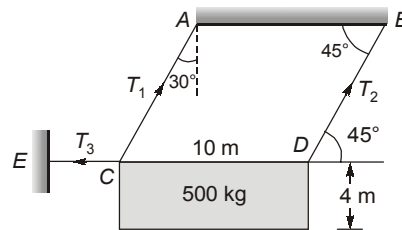

Considering free body diagram of the block.

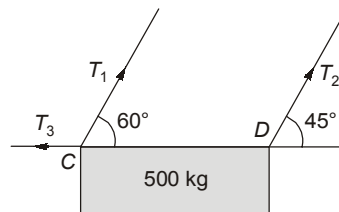

\therefore The body is in equilibrium,
Now, taking moment about C

$$\therefore T_2 \sin 45^\circ \times 10 = 500 \times 5$$

$$T_2 = 353.55 \text{ kg}$$

30. (b)

Drawing free-body diagram of A and B.

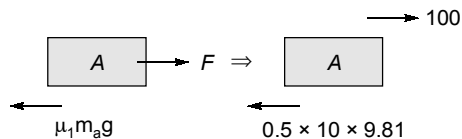

Writing equation of motion for A.

$$100 - 0.5 \times 10 \times 9.81 = 10a$$

$$\Rightarrow a = 5.095 \text{ m/s}^2$$

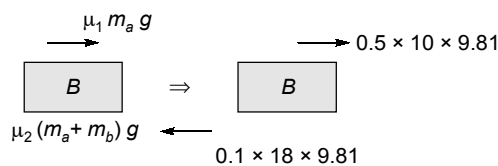

Writing equation of motion for B.

$$49.05 - 17.658 = 8a$$

$$\Rightarrow a = 3.924 \text{ m/s}^2$$

After 0.1s,

$$V_A = U_a + a_a t$$

$$V_A = 0 + 5.095 \times 0.1$$

$$V_A = 0.5095 \text{ m/s}$$

Similarly,

$$V_B = 0 + 3.924 \times 0.1$$

$$V_B = 0.3924$$

\therefore Relative velocity of A wrt B

$$= V_A - V_B$$

$$= 0.5095 - 0.3924 = 0.117 \text{ m/s}$$

