

CLASS TEST

S.No. : 03 GH1_ME_B_220519

Theory of Machine



MADE EASY

India's Best Institute for IES, GATE & PSUs

Delhi | Noida | Bhopal | Hyderabad | Jaipur | Lucknow | Indore | Pune | Bhubaneswar | Kolkata | Patna

Web: www.madeeasy.in | E-mail: info@madeeasy.in | Ph: 011-45124612

CLASS TEST 2019-2020

MECHANICAL ENGINEERING

Theory of Machine

Date of Test : 22/05/2019

Answer Key

- | | | | | |
|--------|---------|---------|---------|---------|
| 1. (b) | 7. (a) | 13. (a) | 19. (b) | 25. (a) |
| 2. (d) | 8. (c) | 14. (d) | 20. (a) | 26. (c) |
| 3. (a) | 9. (c) | 15. (b) | 21. (d) | 27. (d) |
| 4. (b) | 10. (a) | 16. (c) | 22. (c) | 28. (b) |
| 5. (c) | 11. (c) | 17. (c) | 23. (d) | 29. (d) |
| 6. (d) | 12. (b) | 18. (b) | 24. (d) | 30. (b) |

DETAILED EXPLANATIONS

2. (d)

Response to change in speed should be fast.

4. (b)

Kinetic energy, $KE = \frac{1}{2} I \omega^2$

$$\omega = \frac{2\pi N}{60} = \frac{2\pi \times 600}{60} = 62.89 \text{ rad/s}$$

Moment of inertia, $I = \frac{1}{2} mR^2$

$$= \frac{1}{2} \times 25 \times (0.2)^2 = 0.5 \text{ kg-m}^2$$

Hence, $KE = \frac{1}{2} \times 0.5 \times (62.83)^2$

$$= 986.9 \text{ Joules} \approx 987 \text{ J}$$

5. (c)

Angular velocity of connecting rod is given as

$$\omega_c = \omega \frac{\cos \theta}{\sqrt{n^2 - \sin^2 \theta}} \quad (\theta \text{ is crank angle})$$

At $\theta = 0^\circ$, $\omega_c = \frac{\omega}{\sqrt{n^2}} = \frac{\omega}{n} \neq 0$

$$\theta = 45^\circ$$

$$\omega_c = \frac{\omega}{\sqrt{2} \times \sqrt{n^2 - \frac{1}{2}}} = \frac{\omega \sqrt{2}}{\sqrt{2n^2 - 1}} \neq 0$$

$$\theta = 90^\circ, \omega_c = \frac{\omega \times 0}{\sqrt{n^2 - 1}} = 0$$

$$\theta = 180^\circ, \omega_c = -\frac{\omega}{n} \neq 0$$

11. (c)

Moment of inertia of solid disc,

$$I = \frac{mR^2}{2}$$

Mass of solid disc = Density \times Volume

$$= \rho \times \pi R^2 \times \text{thickness}$$

$$= 7810 \times \pi \times (0.135)^2 \times 30 \times 10^{-3} = 13.415 \text{ kg}$$

$$I = 13.415 \times \frac{(0.135)^2}{2} = 0.1222 \text{ kg.m}^2$$

Gyroscopic couple, $C_p = I \omega \omega_p$

$$= 0.1222 \times 15 \times 7 = 12.8356 \text{ N.m}$$

12. (b)

$$m = 10 \text{ tonne} = 10000 \text{ kg}, K = 0.8 \text{ m}, N = 1800 \text{ rpm}$$

$$\omega = \frac{2\pi N}{60} = \frac{2\pi \times 1800}{60} = 188.5 \text{ rad/s}, V = 100 \text{ km/h}, R = 75 \text{ m}$$

MOI of rotor,

$$I = m K^2 \\ = 10000 \times 0.8^2 = 6400 \text{ kg.m}^2$$

Angular velocity of precession

$$\omega_p = \frac{V}{R} = \frac{100 \times 1000}{3600} \times \frac{1}{75} = 0.37 \text{ rad/s}$$

$$C = I\omega\omega_p \\ = 6400 \times 188.5 \times 0.37 = 446.815 \text{ kN.m}$$

14. (d)

$$\omega = \frac{2\pi N}{60} = \frac{2\pi \times 300}{60} = 31.4 \text{ rad/s}$$

$$s = 40 \text{ mm}, 0.04 \text{ m}, \theta_A = 90^\circ = \frac{\pi}{2} \text{ rad} = 1.571 \text{ rad}$$

$$\theta_D = 60^\circ = \frac{\pi}{3} \text{ rad} = 1.047 \text{ rad}$$

$$a_{\max}|_{\text{Rise}} = \frac{\pi^2 \omega^2 s}{2(\theta_A)^2} = \frac{\pi^2 \times 31.4^2 \times 0.04}{2(1.571)^2} = 78.856 \text{ m/s}^2$$

$$a_{\max}|_{\text{Return}} = \frac{\pi^2 \omega^2 s}{2(\theta_D)^2} = \frac{\pi^2 \times 31.4^2 \times 0.04}{2(1.047)^2} = 177.54 \text{ m/s}^2$$

$$\text{Difference} = 177.54 - 78.856 = 98.684 \text{ m/s}^2$$

15. (b)

The pressure angle can be reduced by increasing the angle of rotation of the cam, thereby lengthening the pitch curve for the specified follower displacement. The cam profile becomes flatter and pressure angle becomes smaller.

16. (c)

The equation for cycloidal motion is

$$y = L \left(\frac{\theta}{\beta} - \frac{1}{2\pi} \sin \frac{2\pi\theta}{\beta} \right)$$

Here

$$L = 1.5 \text{ cm} = 15 \text{ mm}, \beta = 180^\circ = \pi \text{ rad}, \theta = \frac{\pi}{3}$$

$$y = 15 \left[\frac{\pi}{3\pi} - \frac{1}{2\pi} \sin \frac{2\pi}{3} \right] = 15 \left[\frac{1}{3} - \frac{1}{2\pi} \times 0.866 \right]$$

$$= 15 \times 0.1955$$

$$y = 2.9326 \text{ mm}$$

17. (c)

$$y' = \frac{L}{\beta} \left[30 \left(\frac{\theta}{\beta} \right)^2 - 60 \left(\frac{\theta}{\beta} \right)^3 + 30 \left(\frac{\theta}{\beta} \right)^4 \right]$$

$$y'' = \frac{L}{\beta^2} \left[60 \frac{\theta}{\beta} - 180 \left(\frac{\theta}{\beta} \right)^2 + 120 \left(\frac{\theta}{\beta} \right)^3 \right]$$

$$y''' = \frac{L}{\beta^3} \left[60 - 360 \frac{\theta}{\beta} + 360 \left(\frac{\theta}{\beta} \right)^2 \right]$$

18. (b)

Height of watt governor considering the weight of the arm:

$$h = \frac{g}{\omega^2} \left[\frac{W + \frac{W_a}{2}}{W + \frac{W_a}{3}} \right]$$

$$= \frac{9.81 \times 3600}{4\pi^2 \times 90^2} \left[\frac{24 + \frac{6}{2}}{24 + \frac{6}{3}} \right] = 0.11044 \left[\frac{24 + 3}{24 + 2} \right]$$

$$= 0.11044 \times \frac{27}{26} = 0.1147 \text{ m or } 114.7 \text{ mm}$$

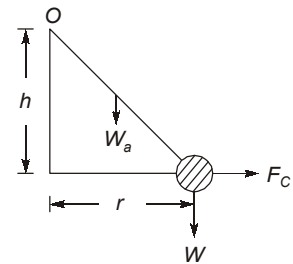

19. (b)

$$\omega_1 = \frac{2\pi \times 200}{60} = 20.944 \text{ rad/s}$$

$$\omega_2 = \frac{2\pi \times 220}{60} = 23.04 \text{ rad/s}$$

$$F_1 = m \omega_1^2 r_1 = 3 \times 0.04 \times (20.944)^2 = 52.638 \text{ N}$$

$$F_2 = m \omega_2^2 r_2 = 3 \times 0.06 \times (23.04)^2 = 95.55 \text{ N}$$

Spring constant,
$$K = 2 \left(\frac{a}{b} \right)^2 \left(\frac{F_2 - F_1}{r_2 - r_1} \right) = 2 \times 1^2 \left(\frac{95.55 - 52.638}{60 - 40} \right) = 4.29 \text{ N/mm}$$

20. (a)

Mathematical condition for stability is given as $\frac{dF}{dr} > \frac{F}{r}$

$$\frac{dF}{dr} = \frac{F_2 - F_1}{r_2 - r_1} = \frac{50 - 25}{70 - 30} = \frac{25}{40} = 0.625 \text{ N/mm}$$

$$\frac{F_1}{r_1} = \frac{25}{30} = 0.833 \text{ N/mm}$$

$$\frac{F_2}{r_2} = \frac{50}{70} = 0.7143 \text{ N/mm}$$

We can observe that $\frac{dF}{dr} < \frac{F_1}{r_1}$ or $\frac{F_2}{r_2}$

So, the governor is unstable.

21. (d)

The function of a governor is to maintain the prime mover speed within prescribed limits.

22. (c)

Given,

$$m_1 = m_2 = 1 \text{ kg}$$

$$r_1 = 0.05 \text{ m}$$

$$r_2 = 0.06 \text{ m}$$

Balancing mass,

$$m = 0.2 \text{ kg}$$

$$\sum F_x = 0$$

$$1[-0.06 \cos 30^\circ + 0.05 \cos 0^\circ]\omega^2 = 0.2 \omega^2 x$$

$$5[-0.052 + 0.05] = x$$

$$x = -10 \text{ mm}$$

Similarly,

$$\sum F_y = 0$$

$$1[0.06 \sin 30^\circ]\omega^2 = 0.2 \omega^2 y$$

$$y = 0.15 \text{ m} = 150 \text{ mm}$$

Position of balancing mass,

$$r = \sqrt{x^2 + y^2} = \sqrt{10^2 + 150^2} = 150.33 \text{ mm}$$

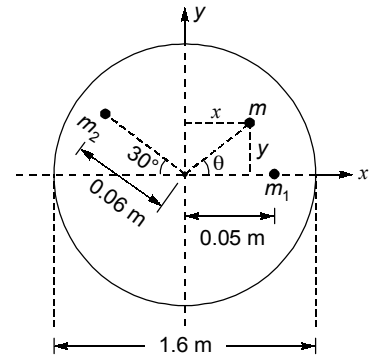

23. (d)

Angular velocity,
$$\omega = \frac{2\pi N}{60} = \frac{2\pi \times 750}{60} = 78.5 \text{ rad/s}$$

The centrifugal forces due to the masses are

$$F_1 = m_1 r_1 \omega^2 = 3 \times 0.3 \times (78.5)^2 \times 10^{-3} = 5.55 \text{ kN}$$

$$F_2 = m_2 r_2 \omega^2 = 10 \times 0.15 \times (78.5)^2 \times 10^{-3} = 9.24 \text{ kN}$$

In vector form, these forces can be written as

$$F_1 = 5.55 \angle 135^\circ = -3.92\vec{i} + 3.92\vec{j}$$

$$F_2 = 9.24 \angle -150^\circ = -8.00\vec{i} - 4.62\vec{j}$$

Here \vec{i} , \vec{j} and \vec{k} are unit vectors along x , y and z axis, respectively. To find bearing reactions at B, we take moments about the bearing at A. This equation is written as

$$\sum M_A = 0.3\vec{k} \times [(-3.92\vec{i} + 3.92\vec{j}) + (-8\vec{i} - 4.62\vec{j})] + 0.5\vec{k} \times F_B = 0$$

$$= 0.3\vec{k} \times [-11.92\vec{i} - 0.7\vec{j}] + 0.5\vec{k} \times F_B = 0$$

$$= -3.576\vec{j} + 0.21\vec{i} + 0.5\vec{k} \times F_B = 0$$

$$0.5\vec{k} \times F_B = -0.21\vec{i} + 3.576\vec{j}$$

$$0.5\vec{k} \times (F_{Bx}\vec{i} + F_{By}\vec{j}) = -0.21\vec{i} + 3.576\vec{j}$$

$$-0.5F_{By}\vec{i} + 0.5F_{Bx}\vec{j} = -0.21\vec{i} + 3.576\vec{j}$$

$$F_{Bx} = \frac{3.576}{0.5} = 7.152, F_{By} = \frac{-0.21}{0.5} = F_{By} = -0.42$$

$$\vec{F}_B = 7.152\vec{i} - 0.42\vec{j}, |\vec{F}_B| = 7.1643 \text{ kN}$$

We can find reaction at A in similar manner.

25. (a)

$$L = 200 \text{ mm} = 0.2 \text{ m}$$

$$\text{Crank length } r = \frac{L}{2} = \frac{200}{2} = 100 \text{ mm} = 0.1 \text{ m}$$

$$N = 600 \text{ rpm}, L = 500 \text{ mm} = 0.5 \text{ m}$$

$$m_R = 150 \text{ kg}$$

$$\omega = \frac{2\pi N}{60} = \frac{2\pi \times 600}{60} = 20\pi = 62.832 \text{ rad/s}$$

$$n = \frac{l}{r} = \frac{0.5}{0.1} = 5$$

$$\begin{aligned} \text{Inertia force, } F_I &= m_R \omega^2 r \left(\cos\theta + \frac{\cos 2\theta}{n} \right) \\ &= 150 \times (62.832)^2 \times 0.1 \left(\cos 60^\circ + \frac{\cos 120^\circ}{5} \right) \\ &= 59.2176 \times 10^3 \left(0.5 - \frac{0.5}{5} \right) \\ &= 23.687 \times 10^3 \text{ N} = 23.687 \text{ kN} \end{aligned}$$

26. (c)

$$r = 50 \text{ mm}$$

$$l = 200 \text{ mm}$$

$$n = \frac{l}{r} = 4$$

$$\begin{aligned} x &= r \left[(1 - \cos\theta) + \frac{\sin^2 \theta}{2n} \right] \\ &= r \left[(1 - \cos\theta) + \frac{1 - \cos^2 \theta}{2n} \right] \end{aligned}$$

$$10 = 50 \left[(1 - \cos\theta) + \frac{1 - \cos^2 \theta}{8} \right]$$

$$10 = 50 - 50 \cos\theta + 6.25 - 6.25 \cos^2 \theta$$

$$6.25 \cos^2 \theta + 50 \cos\theta - 56.25 = 0$$

Solving this quadratic equation, we get $\theta = 33.14^\circ$

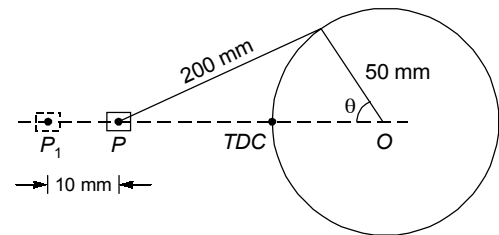

27. (d)

Total fluctuation of speed, $\omega_1 - \omega_2 = 2 \times 0.005 \omega = 0.01 \omega$

$$C_s = \frac{\omega_1 - \omega_2}{\omega} = 0.01$$

$$\omega = \frac{2\pi N}{60} = \frac{2\pi \times 90}{60} = 9.426 \text{ rad/s}$$

$$\text{Work done per cycle} = \frac{P \times 60}{N} = \frac{300 \times 10^3 \times 60}{90} = 200 \times 10^3 \text{ N.m}$$

Maximum fluctuation of energy, $\Delta E = \text{Work done per cycle} \times C_s$
 $= 200 \times 10^3 \times 0.1 = 20 \times 10^3 \text{ N.m}$

$$\Delta E = m k^2 \omega^2 C_s$$

$$m = \frac{\Delta E}{k^2 \omega^2 C_s} = \frac{20 \times 10^3}{(2.5)^2 (9.426)^2 \times 0.01} = 3601.6 \text{ kg}$$

28. (b)

$$T = 20000 + 9500 \sin 2\theta - 5700 \cos 2\theta$$

$$T_{\text{mean}} = 20000 \text{ N.m}$$

$$T = T_{\text{mean}}$$

$$20000 = 20000 + 9500 \sin 2\theta - 5700 \cos 2\theta$$

$$9500 \sin 2\theta = 5700 \cos 2\theta$$

$$\tan 2\theta = \frac{\sin^2 2\theta}{\cos 2\theta} = \frac{5700}{9500} = 0.6$$

$$2\theta = 31^\circ \text{ or } \theta = 15.5^\circ$$

$$\theta = 15.5^\circ \text{ and } 90^\circ + 15.5^\circ = 105.5^\circ$$

30. (b)

$$\omega = \frac{2\pi \times 3000}{60} = 314.2 \text{ rad/s}$$

Maximum primary force = $\frac{3m}{2} \omega^2 r$

$$= \frac{3 \times 1.5}{2} \times (314.2)^2 \times \frac{100}{2} \times 10^{-3}$$

$$= 11106 \text{ N} = 11.1 \text{ kN}$$

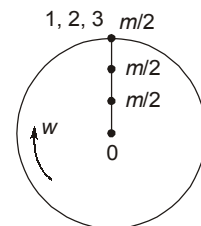

Direct primary cranks

