



MADE EASY

Leading Institute for IES, GATE & PSUs

Delhi | Bhopal | Hyderabad | Jaipur | Pune

Web: www.madeeasy.in | E-mail: info@madeeasy.in | Ph: 011-45124612

ANALOG ELECTRONICS

ELECTRICAL ENGINEERING

Date of Test : 09/06/2026

ANSWER KEY >

- | | | | | |
|--------|---------|---------|---------|---------|
| 1. (d) | 7. (d) | 13. (c) | 19. (b) | 25. (a) |
| 2. (d) | 8. (d) | 14. (d) | 20. (a) | 26. (b) |
| 3. (a) | 9. (b) | 15. (b) | 21. (b) | 27. (d) |
| 4. (b) | 10. (d) | 16. (c) | 22. (b) | 28. (a) |
| 5. (a) | 11. (d) | 17. (a) | 23. (b) | 29. (a) |
| 6. (d) | 12. (c) | 18. (d) | 24. (d) | 30. (b) |

DETAILED EXPLANATIONS

1. (d)
Maximum current is drawn in saturation while minimum current is drawn in cut-off.
2. (d)
The circuit can be redrawn as,

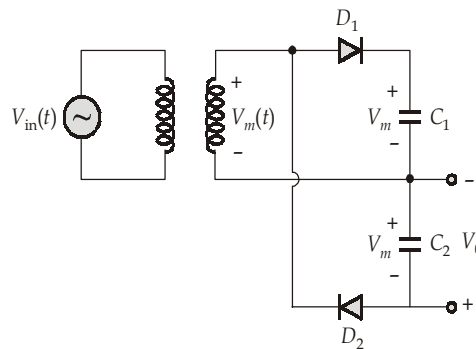

The circuit represents a voltage doubler circuit, if the voltage was taken by adding voltages of both the capacitors, but to calculate V_0 we have to find the voltage stored on a single capacitor. Thus, comparing from the above figure,

$$V_0 = -V_m$$

3. (a)
Drawing the Thevenin equivalent circuit, we get

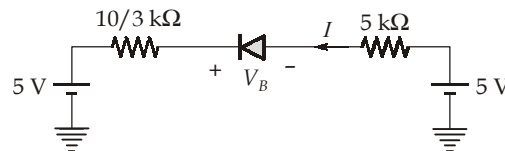

Applying KVL we get $V_D = 0$ V, thus no current will flow through the diode D_1 . Hence,

$$I = 0 \text{ A}$$

4. (b)

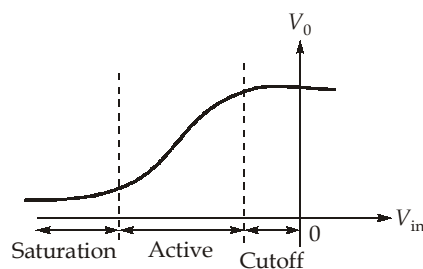

5. (a)
6. (d)
7. (d)
 \therefore It is a voltage doubler circuit.
8. (d)
BJTs can supply more current than MOSFETs because the channel formed in the MOS is smaller than the channel in BJTs.

9. (b)

The diode will work as a half wave rectifier

thus,

$$I_{dc} = \frac{I_m}{\pi}$$

$$R = 1000 + 40 = 1040 \Omega$$

Now,

$$I_m = \frac{V_m}{R} = \frac{110 \times \sqrt{2}}{1040} = 149.58 \text{ mA}$$

$$\therefore I_{dc} = \frac{149.58}{\pi} = 47.61 \text{ mA}$$

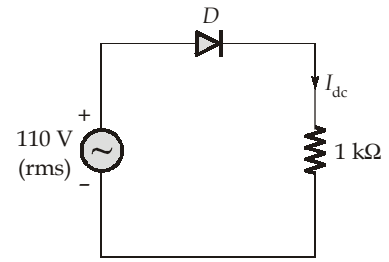

10. (d)

$$V_j = V_T \ln \left(\frac{N_A N_D}{n_i^2} \right)$$

$\therefore V_j$ increases if N_A or N_D increases.

11. (d)

Given,

Base current,

$$I_B = 25 \mu\text{A}$$

$$I_{CBO} = 200 \text{ nA}$$

$$\alpha = 0.98$$

where,

$$\beta = \frac{\alpha}{1 - \alpha} = \frac{0.98}{1 - 0.98} = 49$$

Collector current,

$$I_C = \beta I_B + (1 + \beta) I_{CBO}$$

$$\therefore I_C = 49 \times 25 \times 10^{-6} + (50) \times 200 \times 10^{-9}$$

$$I_C = 1.235 \times 10^{-3} \text{ A}$$

Emitter current,

$$I_E = I_C + I_B$$

$$= 1.235 \text{ mA} + 0.025 \text{ mA}$$

$$\therefore I_E = 1.26 \text{ mA}$$

12. (c)

The small signal equivalent model can be drawn as

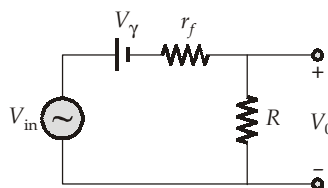

\therefore The output can be expressed as,

$$V_0 = \frac{R}{R + r_f} V_{in} - \frac{R}{R + r_f} V_\gamma \quad \dots(i)$$

Thus, the slope of line in the graph of the input output curve can be written

$$\text{Slope} = \frac{R}{R + r_f} = \frac{1.2}{2 - 0.7} = \frac{1.2}{1.3} \quad \dots\text{from equation (i)}$$

Thus,

$$r_f = 83.33 \Omega$$

13. (c)

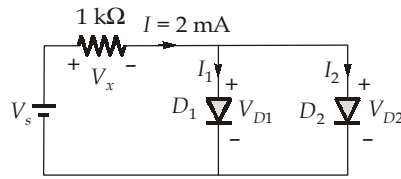

$$V_s = V_x + V_{D1} \quad (\because V_{D1} = V_{D2})$$

and

$$I = I_1 + I_2$$

thus

$$2 \times 10^{-3} = 10^{-12} \left[e^{\frac{V_{D1}}{26 \times 10^{-3}}} - 1 \right] + 10^{-10} \left[e^{\frac{V_{D1}}{26 \times 10^{-3}}} - 1 \right]$$

$$2 \times 10^{-3} \approx 10^{-10} (1.01) \cdot e^{\frac{V_{D1}}{26 \times 10^{-3}}}$$

$$\frac{V_{D1}}{26 \times 10^{-3}} = \ln(1.9801 \times 10^7) = 16.801$$

∴

$$V_{D1} = 0.437 \text{ V}$$

Now,

$$V_x = 2 \times 10^{-3} \times 1 \times 10^3 = 2 \text{ V}$$

$$V_s = V_x + V_{D1} = 2 + 0.437 = 2.437 \text{ V}$$

14. (d)

By applying superposition theorem, we get,

When V_1 at non-inverting terminal is shorted

$$V_{01} = -\frac{40}{20} V_1 = -2V_1 \quad \dots(i)$$

When V_1 at inverting terminal is shorted, then

$$V_{02} = \left[1 + \frac{40}{20} \right] \times \left[\frac{30}{30+30} \right] V_1 = 3 \times \frac{3}{6} V_1 = 1.5 V_1 \quad \dots(ii)$$

Combining equation (i) and (ii), we get,

$$\begin{aligned} V_0 &= V_{01} + V_{02} = -2V_1 + 1.5V_1 \\ &= -\frac{V_1}{2} \end{aligned}$$

15. (b)

$$V_{P-P} = 8 \text{ V}$$

Thus,

$$v(t) = 4 \sin(\omega t)$$

$$V^- = 2 \text{ V}$$

∴

$$\text{Duty cycle} = \frac{T_{\text{on}}}{T_{\text{total}}} = \frac{\theta_{\text{on}}}{\theta_{\text{total}}}$$

now,

$$\theta_1 = \sin^{-1} \left(\frac{2}{4} \right)$$

$$\theta_1 = \frac{\pi}{6}$$

and

$$\theta_2 = \pi - \frac{\pi}{6} = \frac{5\pi}{6}$$

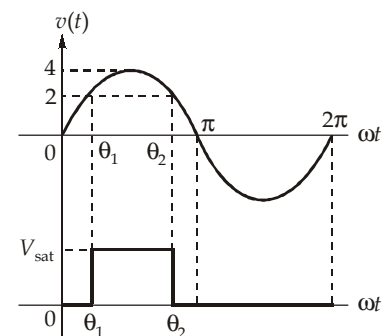

thus, $\theta_{on} = \frac{5\pi}{6} - \frac{\pi}{6}$ and $\theta_{total} = 2\pi$

\therefore Duty cycle = $\frac{\frac{5\pi}{6} - \frac{\pi}{6}}{2\pi} \times 100 = 33.33\%$

16. (c) Applying KVL in base-emitter loop, we get,

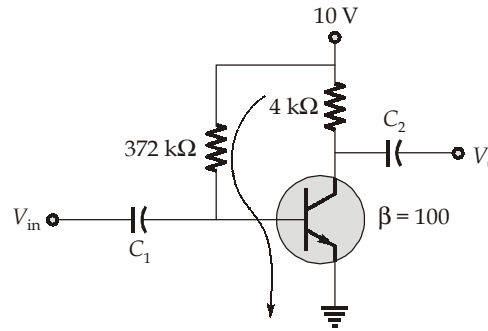

$$I_B = \frac{10 - 0.7}{372 \text{ k}\Omega} = 25 \mu\text{A}$$

To draw the small signal we need to calculate r_π

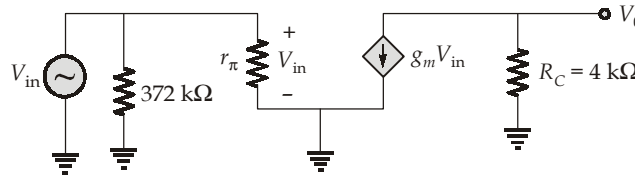

\therefore $r_\pi = \frac{V_T}{I_{BDC}} = \frac{25 \times 10^{-3}}{25 \times 10^{-6}} = 10^3 \Omega$

now, $g_m = \frac{\beta}{r_\pi} = \frac{100}{10^3} = 0.1 \text{ A/V}$

now, $A_v = \frac{V_0}{V_{in}} = -g_m R_C = -0.1 \times 4 \times 10^3 = -400$

17. (a) The current of both the transistors are equal since they are perfectly matched.

Thus, $\frac{I}{2} = \frac{1}{2} \mu_n C_{ox} \left(\frac{W}{L} \right) (V_{GS1} - V_t)^2$

$$10 \times 10^{-3} = \frac{1}{2} \times 500 \times 10^{-6} \times 100 (V_{GS1} - 0.5)^2$$

\therefore $V_{GS1} = V_{GS2} = 1.132 \text{ V}$

Thus, $V_S = V_{cm} - V_{GS1} = 3 - 1.132 = 1.868 \text{ V}$

18. (d)

$$|A_V| = |g_m R_D|$$

Since the configuration is CG configuration,

The input resistance, $R_{in} = \frac{1}{g_m}$

$\Rightarrow \frac{1}{g_m} = 50$

$\therefore A_V = \frac{1}{50} \times R_D$

$10 = \frac{1}{50} \times R_D$

$R_D = 500 \Omega$

19. (b)

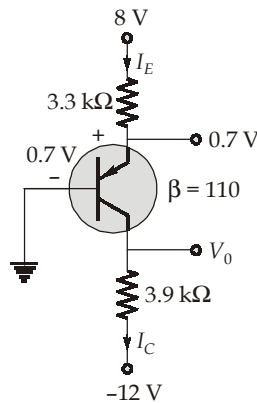

$$I_E = \frac{8 - 0.7}{3.3 \text{ k}\Omega} = 2.212 \text{ mA}$$

$$I_C = \alpha I_E = \frac{110}{111} \times 2.212 \text{ mA} = 2.192 \text{ mA}$$

Now,

$$V_0 = -12 + I_C \times 3.9 \times 10^3 = -3.45 \text{ V}$$

20. (a)

$$V_0 = 5 \text{ V}$$

$$\therefore I_E \approx I_C = \frac{5}{100} = 50 \text{ mA}$$

$$I_Z = \frac{15 - 5}{50 \text{ k}\Omega} = 0.2 \text{ mA} \quad [\text{Since, } \beta \text{ is very large}] \quad V_Z = 5 \text{ V}$$

$$\therefore I_{net} = 50 + 0.2 = 50.2 \text{ mA}$$

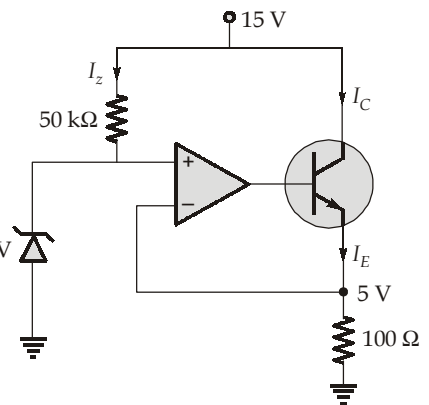

21. (b)

The above circuit can be represented as,

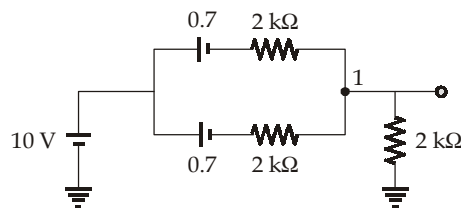

Applying KCL at node 1,

$$\frac{V_0}{2k} + \frac{V_0 - 10 + 0.7}{2k} + \frac{V_0 - 10 + 0.7}{2k} = 0$$

$$V_0 \left[\frac{3}{2k} \right] = \frac{9.3}{1k}$$

$$V_{out} = \frac{9.3}{3} \times 2 = 6.2 \text{ V}$$

22. (b)

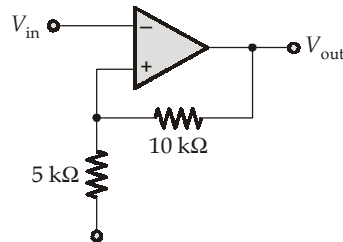

$$V_1 = \frac{3 \times 10 + V_0 \times 5}{15} = \frac{6 + V_0}{3}$$

$$V_{UT} = \frac{6 + 15}{3} = 7 \text{ V}$$

$$V_{LT} = \frac{6 - 15}{3} = -3 \text{ V}$$

23. (b)

This is a Wein bridge oscillator,

$$\beta = \frac{V_f(s)}{V_0(s)}$$

Loop gain,

$$A\beta = L(s) = \left(1 + \frac{R_2}{R_1} \right) \frac{V_f(s)}{V_0(s)}$$

$$\beta = \frac{\left(R \parallel \frac{1}{sC} \right)}{\left(R + \frac{1}{sC} \right) \left(R \parallel \frac{1}{sC} \right)}$$

$$L(s) = \left(1 + \frac{R_2}{R_1} \right) \left(\frac{1}{3 - sRC + \frac{1}{sRC}} \right)$$

$$L(j\omega) = \left(1 + \frac{R_2}{R_1} \right) \left(\frac{1}{3 + j\omega RC + \frac{1}{j\omega RC}} \right)$$

to produce oscillations at $\omega = \omega_0$

$$L(j\omega_0) = 1$$

$$\omega_0 RC - \frac{1}{\omega_0 RC} = 0$$

$$\omega_0 = \frac{1}{RC}$$

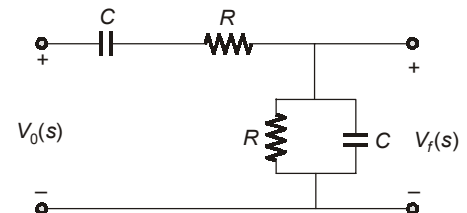

So,

$$1 = \left(1 + \frac{R_2}{R_1}\right) \left(\frac{1}{3}\right)$$

$$\Rightarrow \frac{R_2}{R_1} = 2$$

So, to sustain oscillations, we must have $\frac{R_2}{R_1} \geq 2$

24. (d)

Initially assume each diode is in its conducting state

$$V_B = -0.7 \text{ V}$$

and
$$V_A = 0.7 - 0.7 = 0 \text{ V}$$

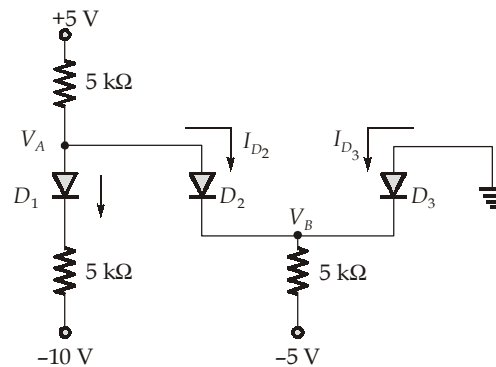

Applying KCL at node A,

$$\frac{5 - V_A}{5k} = I_{D2} + \frac{(V_A - 0.7) - (-10)}{5k}$$

Since,
$$V_A = 0$$

$$I_{D2} = \frac{5 - 9.3}{5k}$$

$$I_{D2} = -0.86 \text{ mA}$$

Which is in consistent with the assumption that all diodes are ON.

Now assume that D_1 and D_3 are ON and D_2 is OFF

Applying KVL in the loop,

$$-5 + (I_{D1} \times 5k) + 0.7 + (I_{D1} \times 5k) - 10 = 0$$

$$I_{D1} = \frac{15 - 0.7}{10k} = 1.43 \text{ mA}$$

$$\therefore V_A = 0.7 + (I_{D1} \times 5k) - 10$$

$$= 0.7 + (1.43 \times 5) - 10$$

$$V_A = -2.15 \text{ V}$$

25. (a)

For input voltage to be positive ($V_{in} > 0$)

D_1 is OFF and D_2 is ON

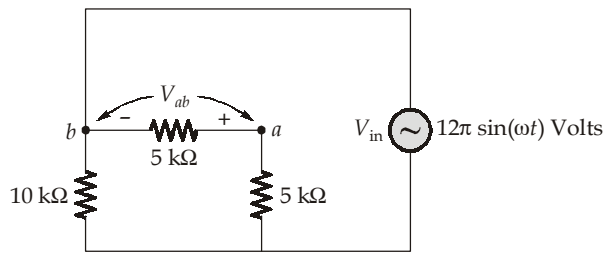

$$V_{ab} = -\frac{5}{5+5}V_{in} = -\frac{1}{2}V_{in}$$

For $V_{in} < 0$, D_1 is ON and D_2 is OFF.

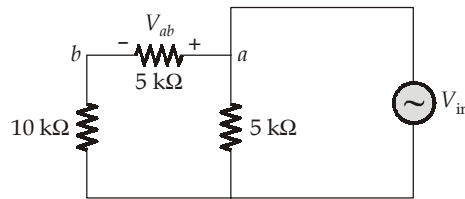

$$V_{ab} = \frac{5}{5+10}V_{in} = \frac{V_{in}}{3}$$

So,

$$V_{ab} = \begin{cases} -\frac{V_{in}}{2} & V_{in} > 0 \\ \frac{V_{in}}{3} & V_{in} < 0 \end{cases}$$

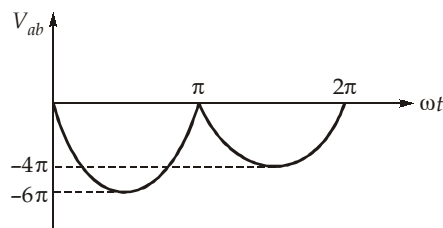

$$\text{Average value} = V_{ab} = -\frac{6\pi}{\pi} - \frac{4\pi}{\pi} = -10 \text{ Volts}$$

[2 Marks, MCQ]

26. (b)

By Concept of virtual short

$$I_1 = \frac{V_i}{100 \times 10^{-3}} = 10V_i$$

By Y-parameter equation,

$$\begin{aligned} I_1 &= Y_{11}V_1 + Y_{12}V_2 \\ I_2 &= Y_{12}V_1 + Y_{22}V_2 \end{aligned}$$

Here,

$$V_1 = 0,$$

$$I_1 = 10 V_i$$

So,

$$I_1 = 10V_i = (0) + Y_{12}V_2$$

$$10 V_i = \frac{-1}{12}V_2$$

$$V_2 = -10 \times 12 V_i = -120V_i$$

But $V_o = V_2$

So,

$$V_o = -120V_i$$

$$\frac{V_o}{V_i} = -120$$

27. (d)

The AC equivalent circuit of MOS

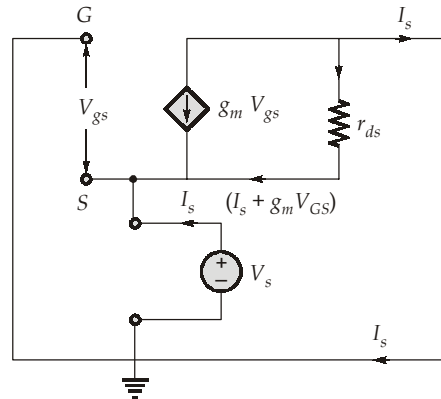

$$V_{gs} = -V_s \quad \dots(i)$$

$$V_s = (I_s - g_m V_s) r_{ds}$$

$$V_s + g_m r_{ds} V_s = I_s r_{ds}$$

$$V_s(1 + g_m r_{ds}) = r_{ds} I_s$$

$$R_{Th} = \frac{V_s}{I_s} = \frac{r_{ds}}{(1 + g_m r_{ds})}$$

28. (a)

M_1 to be current sat

$$I_{D1} = \frac{1}{2} \mu_n C_{ox} \left(\frac{W}{L} \right)_1 (V_x - 3 - 1)^2$$

$$= \frac{1}{2} \times 100 \times 4 (V_x - 4)^2$$

$$= 200 (V_x - 4)^2$$

M_2 is in current sat

$$I_{D2} = \frac{1}{2} \mu_n C_{ox} \left(\frac{W}{L} \right)_2 (3 - 1)^2$$

$$= \frac{1}{2} \times 100 \times 1 \times (2)^2 = 200$$

$$I_{D1} = I_{D2}$$

$$200 = 200 (V_x - 4)^2$$

$$(V_x - 4) = \pm 1$$

$$V_x = 5, 3$$

$$V_x = 5 \text{ V}$$

29. (a)
The AC equivalent of the BJT

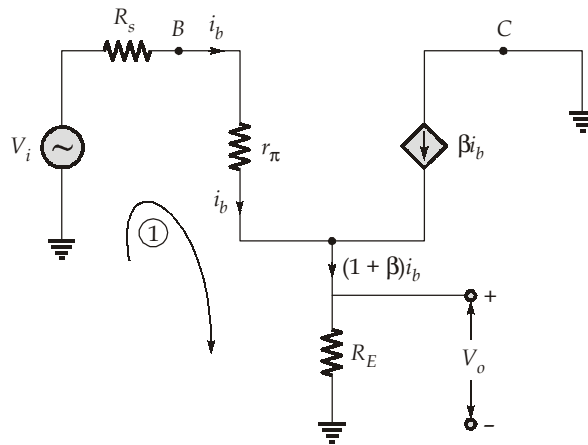

The output voltage,
KVL in loop (1)

$$V_o = (1 + \beta)i_b R_E \quad \dots(i)$$

$$\begin{aligned} V_i &= i_b R_s + r_\pi i_b + (1 + \beta)R_E i_b \\ V_i &= (R_s + r_\pi + (1 + \beta)R_E)i_b \end{aligned} \quad \dots(ii)$$

So, the gain,

$$\frac{V_o}{V_i} = \frac{(1 + \beta) R_E}{R_s + r_\pi + (1 + \beta)R_E} = \frac{(1 + 49) \times 1}{100 + 1.5 + (1 + 49) \times 1} = 0.33$$

30. (b)

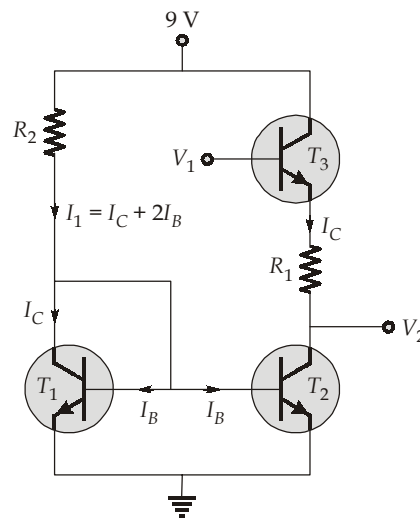

The T_1 and T_2 are current mirror,

$$I_1 = I_C + 2I_B = \frac{V_{CC} - V_{BE}}{R_2}$$

$$I_B = \frac{I_C}{100}$$

So,

$$I_C \left(1 + \frac{2}{100} \right) = \frac{9 - 0.7}{R_2}$$

$$I_C = \frac{9 - 0.7}{(1.02)R_2} = \frac{8.137}{R_2} \quad \dots(i)$$

and $V_1 - V_2 = V_{BE} + I_C R_1$... (ii)
From equations (i) and (ii),

$$V_1 - V_2 = 3 = 0.7 + \frac{8.137}{R_2} \times R_1$$

$$\frac{R_1}{R_2} = \frac{3 - 0.7}{8.137} = 0.28265$$

$$\frac{R_2}{R_1} = 3.54$$

