

ESE

Mechanical Engineering

(Previous Years Solved Papers 1995-1999)

Objectives (Volume-I)

Contents

1. Fluid Mechanics	1-40
2. Thermodynamics	41-59
3. Heat Transfer	60-83
4. Internal Combustion Engines	84-99
5. Refrigeration and Air-conditioning	100-117
6. Turbo Machinery	118-152
7. Power Plant Engineering	153-168



UNIT

I

Fluid Mechanics

Syllabus

Fluid Mechanics: Basic concepts and Properties of fluids, Manometry, Fluid statics, Buoyancy, Equations of motion, Bernoulli's equation and applications, Viscous flow of incompressible fluids, Laminar and Turbulent flows, Flow through pipes and head losses in pipes.

Contents

Sl.	Topic	Page No.
1.	Fluid Properties	2
2.	Fluid Pressure and Measurement	5
3.	Hydrostatic Forces on Surface	8
4.	Buoyancy, Floatation and Liquids in Relative Equilibrium	10
5.	Fluid Kinematics	13
6.	Fluid Dynamics and Flow Measurement	17
7.	Flow Through Pipes	20
8.	Vortex Flow	24
9.	Laminar Flow	26
10.	Turbulent Flow	28
11.	Boundary Layer Theory	30
12.	Open Channel Flow	34
13.	Drag and Lift	36
14.	Dimensional Analysis	38



1

Fluid Properties

1.1 Match **List-I** (Properties of fluids) with **List-II** (Definition/Results) and select the correct answer using the codes given below the lists:

List-I

- A. Ideal fluid
- B. Newtonian fluid
- C. μ/ρ
- D. Mercury in glass

List-II

- 1. Viscosity does not vary with rate of deformation
- 2. Fluid of zero viscosity
- 3. Dynamic viscosity
- 4. Capillary depression
- 5. Kinematic viscosity
- 6. Capillary rise

Codes:

	A	B	C	D
(a)	1	2	4	6
(b)	1	2	3	4
(c)	2	1	3	6
(d)	2	1	5	4

[ESE : 1995]

1.2 Match **List-I** (Fluid properties) with **List-II** (Related terms) and select the correct answer using the codes given below the lists:

List-I

- A. Capillarity
- B. Vapour pressure
- C. Viscosity
- D. Specific gravity

List-II

- 1. Cavitation
- 2. Density of water
- 3. Shear force
- 4. Surface tension

Codes:

	A	B	C	D
(a)	1	4	2	3
(b)	1	4	3	2
(c)	4	1	2	3
(d)	4	1	3	2

[ESE : 1996]

1.3 **Assertion (A):** In fluid, the rate of deformation is far more important than the total deformation itself.

Reason (R): A fluid continues to deform so long as the external forces are applied.

- (a) Both **A** and **R** are individually true and **R** is the correct explanation of **A**
 - (b) Both **A** and **R** are individually true but **R** is not the correct explanation of **A**
 - (c) **A** is true but **R** is false
 - (d) **A** is false but **R** is true
- [ESE : 1996]

1.4 Which one of the following is the bulk modulus K of a fluid? (Symbols have the usual meaning)

- (a) $\rho \frac{dp}{d\rho}$
 - (b) $\frac{dp}{\rho d\rho}$
 - (c) $\rho \frac{d\rho}{dp}$
 - (d) $\frac{d\rho}{\rho dp}$
- [ESE : 1997]

1.5 The dimensions of surface tension are

- (a) N/m^2
 - (b) J/m
 - (c) J/m^2
 - (d) W/m
- [ESE : 1997]

1.6 Which of the following forces act on a fluid at rest?

- 1. Gravity force
 - 2. Hydrostatic force
 - 3. Surface tension
 - 4. Viscous force
- Select the correct answer using the codes given below:
- (a) 1, 2, 3 and 4
 - (b) 1, 2 and 3
 - (c) 2 and 4
 - (d) 1, 3 and 4
- [ESE : 1998]

1.7 Surface tension is due to

- (a) viscous forces
 - (b) cohesion
 - (c) adhesion
 - (d) the difference between adhesive and cohesive forces
- [ESE : 1998]

1.8 Newton's law of viscosity depends upon the

- (a) stress and strain in a fluid
 - (b) shear stress, pressure and velocity
 - (c) shear stress and rate of strain
 - (d) viscosity and shear stress
- [ESE : 1998]

- 1.9 The normal stress is the same in all directions at a point in a fluid only when
- the fluid is frictional
 - the fluid is frictionless and incompressible
 - the fluid has zero viscosity and is at rest
 - one fluid layer has no motion relative to an adjacent layer
- [ESE : 1998]

- 1.10 If the surface tension of water-air interface is 0.073 N/m, the gauge pressure inside a rain drop of 1 mm diameter will be
- 0.146 N/m²
 - 73 N/m²
 - 146 N/m²
 - 292 N/m²

[ESE : 1999]

■■■■

Answers Fluid Properties

- 1.1 (d) 1.2 (d) 1.3 (a) 1.4 (a) 1.5 (c) 1.6 (b) 1.7 (b) 1.8 (c) 1.9 (d)
- 1.10 (d)

Explanations Fluid Properties**1.1 (d)**

A Newtonian fluid is a fluid whose stress versus strain rate curve is linear and passes through origin. The constant of proportionality is known as the viscosity.

In fluid mechanics, the term (μ/ρ) is observed frequently and hence for convenience, it is called as kinematic viscosity.

The depression of the meniscus of a liquid contained in a tube where the liquid does not wet walls of container, as in mercury barometer, the meniscus has a convex shape, resulting in a depression.

1.2 (d)

Viscosity: It is a measure of resistance of a fluid which is being deformed by either shear stress or tensile stress.

Specific gravity: It is the ratio of density of fluid to the density of standard fluid.

Capillarity: It is the ability of liquid to flow against gravity combination of surface tension and adhesion act to lift the liquid.

1.4 (a)

Bulk modulus,

$$K = -\frac{dp}{dv/v} \quad \dots (i)$$

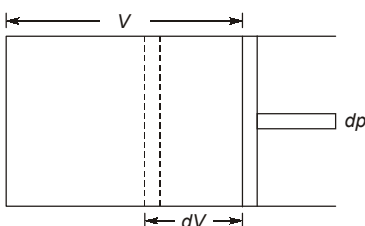

Specific volume,

$$v = \frac{1}{\rho} = \rho^{-1}$$

Taking \log_e both sides, we get

$$\log_e v = -\log_e \rho$$

On differentiating

$$\frac{dv}{v} = -\frac{d\rho}{\rho}$$

Substituting $\frac{dv}{v} = -\frac{d\rho}{\rho}$ in Eq (i), we get

$$K = \frac{-d\rho}{-d\rho/\rho} = \rho \frac{d\rho}{d\rho}$$

1.5 (c)

The property of the liquid surface film to exert a tension is called the surface tension. It is the force required to maintain unit length of the film in equilibrium. In SI units surface tension is expressed in N/m or J/m².

1.6 (b)

For a fluid at rest, there can be no shear force (i.e. viscous force). The only forces acting on the free body are the normal pressure forces, exerted by the surrounding fluid on the plane surface and the weight of the element.

1.7 (b)

Surface tension is due to cohesion between liquid particles at the surface, where as capillarity is due to both cohesion and adhesion.

The property of cohesion enables a liquid to resist tensile stress, while adhesion enables it to stick to another body.

1.8 (c)

Newton's law of viscosity

$$\tau = \mu \frac{du}{dy} \quad \text{where } \tau = \text{shear stress,}$$

$$\frac{du}{dy} = \text{rate of strain}$$

1.9 (d)

The pressure at any point in a fluid at rest has the same magnitude in all directions. In other words, when a certain pressure is applied at any point in a fluid at rest, the pressure is equally transmitted in all the direction and to every other point in the fluid. It is known as Pascal's law.

1.10 (d)

Given: $\sigma = 0.073 \text{ N/m}$, $d = 1 \text{ mm} = 0.001 \text{ m}$
Pressure intensity inside a droplet,

$$p = \frac{4\sigma}{d} = \frac{4 \times 0.073}{0.001} \text{ N/m}^2 = 292 \text{ N/m}^2$$

■■■■

MADE EASY

2

Fluid Pressure and Measurement

2.1 The depth of a fluid is measured in vertical z -direction; x and y are the other two directions and are mutually perpendicular. The static pressure variation in the fluid is given by (symbols have the usual meaning)

- (a) $\frac{dp}{dz} = g$ (b) $\frac{dp}{dz} = \rho$
 (c) $\frac{dp}{dz} = \rho g$ (d) $\frac{dp}{dz} = -\rho g$

[ESE : 1995]

2.2 If z is vertically upwards, ρ is the density and g gravitational acceleration (see figure), then the pressure $\partial p/\partial z$ in fluid at rest due to gravity is given by

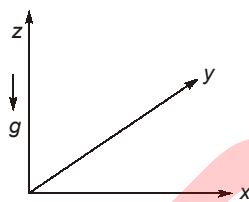

- (a) $\rho g z^2/2$ (b) $-\rho g$
 (c) $-\rho g z$ (d) $\rho g/z$ [ESE : 1996]

2.3 The manometer shown in the figure below connects two pipes, carrying oil and water respectively.

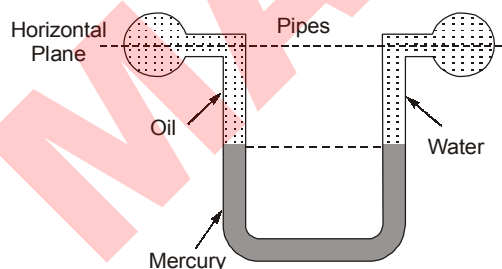

From the figure one

- (a) can conclude that the pressures in the pipes are equal
 (b) can conclude that the pressure in the oil pipe is higher
 (c) can conclude that the pressure in the water pipe is higher

(d) cannot compare the pressure in the two pipes for want of sufficient data

[ESE : 1996]

2.4 **Assertion (A):** U-tube manometer connected to a venturimeter fitted in a pipeline can measure the velocity through the pipe.

Reason (R): U-tube manometer directly measures dynamic and static heads.

- (a) Both **A** and **R** are individually true and **R** is the correct explanation of **A**
 (b) Both **A** and **R** are individually true but **R** is not the correct explanation of **A**
 (c) **A** is true but **R** is false
 (d) **A** is false but **R** is true

[ESE : 1996]

2.5 A differential manometer as shown in figure below is used to measure the difference in pressure at points A and B in terms of specific weight of water, w . The specific gravities of the liquids X , Y and Z are respectively S_1 , S_2 , and S_3 .

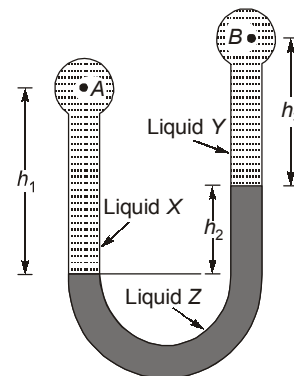

The correct difference $\left(\frac{p_A}{w} - \frac{p_B}{w}\right)$ is given by

- (a) $h_3 S_3 - h_1 S_1 + h_2 S_2$
 (b) $h_1 S_1 + h_2 S_3 - h_3 S_2$
 (c) $h_3 S_1 - h_1 S_2 + h_2 S_3$
 (d) $h_1 S_1 + h_2 S_2 - h_3 S_3$

[ESE : 1997]

2.6 In the figure shown below, air is contained in the pipe and water in the manometer liquid.

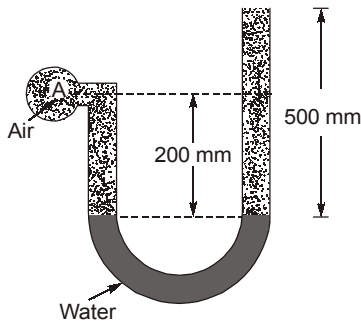

The pressure at A is approximately

- (a) 10.14 m of water absolute
 (b) 0.2 m of water
 (c) 1.2 m of water vacuum
 (d) 4901 Pa

[ESE : 1998]

- 2.7 A mercury manometer is fitted to a pipe. It is mounted on the delivery line of a centrifugal pump. One limb of the manometer is connected to the upstream side of the pipe at A and the other limb at B, just below the valve V as shown in the figure below.

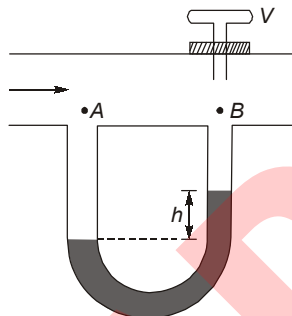

The manometer reading h varies with different valve positions.

Assertion (A): With gradual closure of the valve, the magnitude of h will go on increasing and even a situation may arise when mercury will be sucked in by the water flowing around B.

Reason (R): With the gradual closure of the valve, the pressure at A will go on increasing.

- (a) Both **A** and **R** are individually true and **R** is the correct explanation of **A**
 (b) Both **A** and **R** are individually true but **R** is not the correct explanation of **A**
 (c) **A** is true but **R** is false
 (d) **A** is false but **R** is true

[ESE : 1998]

- 2.8 The reading of gauge A shown in the figure below is

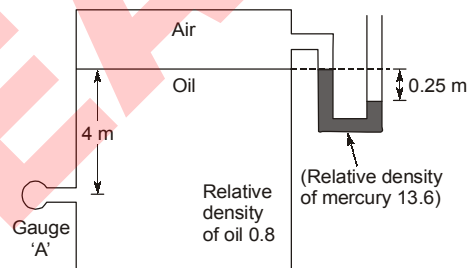

- (a) -31.392 kPa (b) -1.962 kPa
 (c) 31.392 kPa (d) +19.62 kPa

[ESE : 1999]

■■■■

Answers Fluid Pressure and Measurement

- 2.1 (d) 2.2 (b) 2.3 (d) 2.4 (c) 2.5 (a) 2.6 (a) 2.7 (a) 2.8 (b)

Explanations Fluid Pressure and Measurement

2.1 (d)

The pressure intensity p at any point in a static mass of fluid does not vary in x and y directions and it varies only in z -direction.

$$\text{Hence, } \frac{dp}{dz} = -\rho g$$

2.2 (b)

The pressure intensity p at any point in a mass of fluid does not vary in x and y directions and it varies only z direction.

$$\therefore \frac{\partial p}{\partial z} = -\rho g$$

The negative sign in the above equation signifies that the pressure decreases in the direction in which z increases *i.e.* in the upward direction.

2.5 (a)

Starting from point A and writing manometric equation.

$$\frac{p_A}{w} + h_1 S_1 - h_2 S_2 - h_3 S_3 = \frac{p_B}{w}$$

$$\therefore \frac{p_A}{w} - \frac{p_B}{w} = h_3 S_3 - h_1 S_1 + h_2 S_2$$

2.6 (a)

Pressure at A is equal to atmospheric pressure.

2.7 (a)

With gradual closure the valve, the valve will be restricted the flow of liquid. Then pressure at A will be increased.

2.8 (b)

Pressure of air

$$p_{\text{air}} = -0.25 \times 13.6 = -3.4 \text{ m of water}$$

$$\text{Now, } p_{\text{air}} + 4 \times 0.8 = p_A$$

$$\therefore p_A = -3.4 + 3.2 = -0.2 \text{ m of water}$$

$$p_A = -1.962 \text{ kPa}$$

■■■■

MADE EASY

3

Hydrostatic Forces on Surface

- 3.1** A rectangular water tank, full to the brim, has its length, breadth and height in the ratio of 2 : 1 : 2. The ratio of hydrostatic forces at the bottom to that at any larger vertical surface is
 (a) 1/2 (b) 1
 (c) 2 (d) 4 [ESE : 1996]

- 3.2** A cylindrical gate is holding water on one side as shown in the figure below.

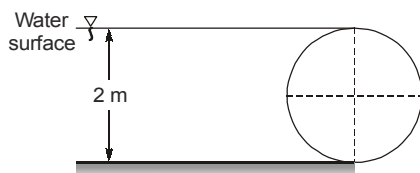

- The resultant vertical component of force of water per meter width of gate will be
 (a) Zero (b) 7700.8 N/m
 (c) 15401.1 N/m (d) 30803.4 N/m
 [ESE : 1997]

- 3.3** A stepped cylindrical container is filled with a liquid as shown in the figure below.

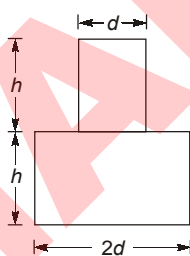

- The container with its axis vertical, is first placed with its larger diameter downward and then upward. The ratio of the forces at the bottom in the two cases will be
 (a) 1/2 (b) 1
 (c) 2 (d) 4 [ESE : 1998]

- 3.4** A circular annular plate having outer and inner diameters of 1.4 m and 0.6 m respectively is immersed in water with its plane making an angle of 60° with the horizontal. The centre of the circular annular plate is 1.85 m below the free surface. The hydrostatic thrust on one side of the plate is
 (a) 1975 N (b) 19.75 N
 (c) 11.4 N (d) 22.8 kN [ESE : 1998]

- 3.5** A hometop water tank is made of flat plates and is full to the brim. Its height is twice that of any side. The ratio of force on the bottom of the tank to that on any side will be
 (a) 4 (b) 2
 (c) 1 (d) 1/2 [ESE : 1998]

- 3.6** A vertical sluice gate, 2.5 m wide and weighing 500 kg is held in position due to horizontal force of water on one side and associated friction force. When the water level drops down to 2 m above the bottom of the gate, the gate just starts sliding down. The coefficient of friction between the gate and the supporting structure is
 (a) 0.20 (b) 0.10
 (c) 0.05 (d) 0.02 [ESE : 1999]

- 3.7 Assertion (A):** Depth of centre of pressure of any immersed surface is independent of the density of liquid.

Reason (R): Centre of area of immersed surface lies below the centre of pressure.

- (a) Both **A** and **R** are individually true and **R** is the correct explanation of **A**
 (b) Both **A** and **R** are individually true but **R** is not the correct explanation of **A**
 (c) **A** is true but **R** is false
 (d) **A** is false but **R** is true [ESE : 1999]



Answers Hydrostatic Forces on Surface

- 3.1 (b) 3.2 (c) 3.3 (d) 3.4 (d) 3.5 (c) 3.6 (b) 3.7 (c)

Explanations Hydrostatic Forces on Surface

3.1 (b)

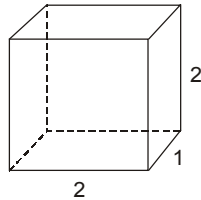

Force on the bottom,

$$F_1 = \rho g(2 \times 1) \times 2 = 4\rho g$$

Force on the vertical surface,

$$F_2 = \rho g(2 \times 2) \times 1 = 4\rho g$$

$$\frac{F_1}{F_2} = 1$$

3.2 (c)

Vertical forces = weight of fluid corresponding to semi circular volume

$$= w \left(\frac{\pi R^2 L}{2} \right) = 9.81 \times 1000 \times \frac{\pi \times (2)^2}{4 \times 2} \times 1$$

$$= 15401.1 \text{ N/m}$$

3.3 (d)

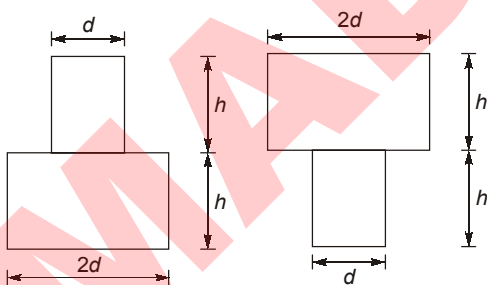

$$F_1 = \rho g \times 2h \times \frac{\pi}{4} \times (2d)^2 = 2\pi\rho ghd^2$$

$$F_2 = \rho g \times 2h \times \frac{\pi}{4} d^2 = \frac{\pi\rho ghd^3}{2}$$

Now, $\frac{F_1}{F_2} = 4$

3.4 (d)

Hydrostatic thrust = $\rho g A \bar{h}$

$$= 9.81 \times \frac{\pi}{4} \times \left\{ (1.4)^2 - (0.6)^2 \right\} \times 1.85 \times 1000$$

$$= 22.8 \text{ kN}$$

3.5 (c)

F_1 = Force at bottom

$$= \gamma \times (a \times a) \times 2a = 2a^3\gamma$$

F_2 = Force at one side

$$= \gamma \times (a \times 2a) \times a = 2a^3\gamma$$

$$\therefore \frac{F_1}{F_2} = 1$$

3.6 (b)

Pressure force

$$= \rho g A \bar{h} = 10 \times 1000 \times 2 \times 2.5 \times 1$$

$$= 50 \text{ kN}$$

$$\Sigma F_x = 0$$

$$\therefore 2N = P = 50$$

$$\therefore N = 25 \text{ kN}$$

Now, $\Sigma F_y = 0$

$$mg = 2\mu N$$

$$\therefore \mu = \frac{500 \times 10}{2 \times 25 \times 1000} = 0.1$$

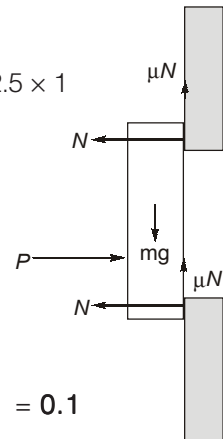

3.7 (c)

Depth of centre of pressure is proportional to second moment of area about the water surface area of surface, and depth of centre of gravity, i.e.

$$h^* = \bar{h} + \frac{I_G \sin^2 \theta}{A \bar{h}}$$

where,

h^* = Depth of pressure

\bar{h} = Centroid of surface area

A = Surface area

I_G = Moment of inertia of the area about an axis passing through the centroid of the area.

θ = Inclination of surface from horizontal.

Centre of area of immersed surface lies above the centre of pressure.



4

Buoyancy, Floatation and Liquids in Relative Equilibrium

4.1 The following terms relate to floating bodies:

Centre of gravity... G ,

Metacentre... M ,

Weight of floating body... W ,

Buoyant force... F_B

Match **List-I** (Condition) with **List-II** (Result) and select the correct answer using the codes given below the lists:

List-I

- A. G is above M
- B. G and M coincide
- C. G is below M
- D. $F_B > W$

List-II

- 1. Stable equilibrium
- 2. Unstable equilibrium
- 3. Floating body
- 4. Neutral equilibrium

Codes:

	A	B	C	D
(a)	1	3	2	4
(b)	3	1	4	2
(c)	2	3	4	1
(d)	2	4	1	3

[ESE : 1995]

4.2 Consider the following statements:

The metacentric height of a floating body depends

- 1. directly on the shape of its water-line area
- 2. on the volume of liquid displaced by the body
- 3. on the distance between the metacentre and the centre of gravity
- 4. on the second moment of water-line area

Which of these statements are correct?

- (a) 1 and 2
- (b) 2 and 3
- (c) 3 and 4
- (d) 1 and 4

[ESE : 1996]

4.3 A large metacentric height in a vessel

- (a) improves stability and makes periodic time of oscillation longer

- (b) impairs stability and makes periodic time of oscillation shorter

- (c) has no effect on stability or the periodic time of oscillation

- (d) improves stability and makes the periodic time of oscillation shorter

[ESE : 1997]

4.4 **Assertion (A):** To increase the stability of an empty ship, ballasts are loaded at the bottom level.

Reason (R): The ballasts increase the weight of the ship.

- (a) Both **A** and **R** are individually true and **R** is the correct explanation of **A**
- (b) Both **A** and **R** are individually true but **R** is not the correct explanation of **A**
- (c) **A** is true but **R** is false
- (d) **A** is false but **R** is true

[ESE : 1997]

4.5 Consider the following statements:

Filling up a part of the empty hold of a ship with ballasts will

- 1. reduce the metacentric height
- 2. lower the position of the centre of gravity
- 3. elevate the position of centre of gravity
- 4. elevate the position of centre of buoyancy

Which of these statements are correct?

- (a) 1, 3 and 4
- (b) 1 and 2
- (c) 3 and 4
- (d) 2 and 4

[ESE : 1998]

4.6 A cylindrical piece of cork weighing W floats with its axis in horizontal position in a liquid of relative density 4. By anchoring the bottom, the cork piece is made to float at neutral equilibrium position with its axis vertical. The vertically downward force exerted by anchoring would be

- (a) $0.5W$
- (b) W
- (c) $2W$
- (d) $4W$

[ESE : 1998]

- 4.7 A triangular dam of height h and base width b is filled to its top with water as shown in the figure below.

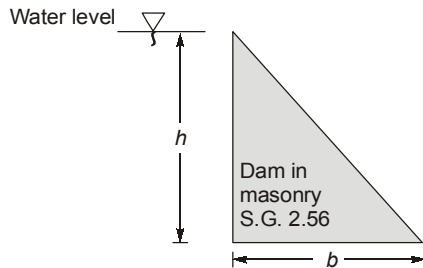

The condition of stability is

- (a) $b = h$ (b) $b = 2.6h$
 (c) $b = \sqrt{3}h$ (d) $b = 0.625h$

[ESE : 1999]

- 4.8 Stability of a freely falling object is assured if its centre of
- (a) buoyancy lies below its centre of gravity
 (b) gravity coincides with its centre of buoyancy
 (c) gravity lies below its metacentre
 (d) buoyancy lies below its metacentre

[ESE : 1999]

- 4.9 Match List-I with List-II regarding a body partly submerged in a liquid and select the correct answer using the codes given below the lists:

List-I

- A. Centre of pressure
 B. Centre of gravity
 C. Centre of buoyancy
 D. Metacentre

List-II

1. Point of application of the weight of displaced liquid
 2. Point about which the body starts oscillating when tilted by a small angle
 3. Point of application of hydrostatic pressure force
 4. Point of application of the weight of the body

Codes:

- | | A | B | C | D |
|-----|---|---|---|---|
| (a) | 4 | 3 | 1 | 2 |
| (b) | 4 | 3 | 2 | 1 |
| (c) | 3 | 4 | 1 | 2 |
| (d) | 3 | 4 | 2 | 1 |

[ESE : 1999]

- 4.10 If a piece of metal having a specific gravity of 13.6 is placed in mercury of specific gravity 13.6, then the

- (a) metal piece will sink to the bottom
 (b) metal piece will simply float over the mercury with no immersion
 (c) metal piece will be immersed in mercury by half
 (d) whole of the metal piece will be immersed with its top surface just at mercury level

[ESE : 1999]

- 4.11 A bucket of water hangs with a spring balance. If an iron piece is suspended into water from another support without touching the sides of the bucket, the spring balance will show

- (a) an increased reading
 (b) a decreased reading
 (c) no change in reading
 (d) increased or decreased reading depending on the depth of immersion

[ESE : 1999]

- 4.12 The least radius of gyration of a ship is 9 m and the metacentric height is 750 mm. The time period of oscillation of the ship is

- (a) 42.41 s
 (b) 75.4 s
 (c) 20.85 s
 (d) 85 s

[ESE : 1999]

- 4.13 **Assertion (A):** If a boat, built with sheet metal on wooden frame, has an average density which is greater than that of water, then the boat can float in water with its hollow face upward but will sink once it overturns.

Reason (R): Buoyant force always acts in the upward direction.

- (a) Both **A** and **R** are individually true and **R** is the correct explanation of **A**
 (b) Both **A** and **R** are individually true but **R** is not the correct explanation of **A**
 (c) **A** is true but **R** is false
 (d) **A** is false but **R** is true

[ESE : 1999]



Answers Buoyancy, Floatation and Liquids in Relative Equilibrium

- 4.1 (d) 4.2 (b) 4.3 (d) 4.4 (b) 4.5 (d) 4.6 (3W) 4.7 (d) 4.8 (c) 4.9 (c)
4.10 (d) 4.11 (a) 4.12 (c) 4.13 (b)

Explanations Buoyancy, Floatation and Liquids in Relative Equilibrium**4.1 (d)**

For completely submerged body stable equilibrium exist when centre of gravity is below centre of buoyancy. Unstable equilibrium exist when centre of gravity is above the centre of buoyancy and neutral equilibrium exists when centre of gravity exists with centre of buoyancy (B).

A floating body will be in stable equilibrium when metacenter is above centre of gravity, in unstable equilibrium when metacenter is below centre of gravity. And if centre of gravity coincide with metacenter, body will be in neutral equilibrium.

4.2 (b)

The metacentric height depends on the volume of liquid displaced and the distance between the metacenter and the centre of gravity.

4.3 (d)

$$T = 2\pi \sqrt{\frac{K^2}{(GM)g}} \quad (GM \uparrow, T \downarrow)$$

Increasing the metacentric height gives stability of a floating, but an increase in the metacentric height reduced the time period of rolling of the body.

4.5 (d)

Metacentric height does not depend on the ballasts, lower the position of the centre of gravity and elevate the position of centre of buoyancy.

4.7 (d)

Moment about O,

$$F_v \times \frac{h}{3} = \frac{W \times 2b}{3}$$

$$W \times h \times 1 \times \frac{h}{2} \times \frac{h}{3} = \frac{bh}{2} \times 1 \times 2.56 \times W \times \frac{2}{3}$$

$$b = 0.625h$$

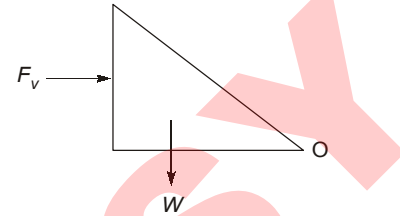
**4.8 (c)**

Stability of a freely falling object when centre of gravity lies below its metacenter.

4.9 (c)

- (a) Centre of pressure : Point of application of hydrostatic pressure force
(b) Centre of gravity : Point of application of the weight of the body
(c) Centre of buoyancy : Point of application of the weight of displace liquid
(d) Metacenter : Point about which the body starts oscillating when tilted by a small angle.

4.10 (d)

When piece of metal and liquid have same specific gravity then metal piece will be considered as the part of liquid.

4.11 (a)

Since the water of bucket will exert force of buoyancy equal to the volume displaced by the iron block. Hence equal and opposite force will be exerted by iron block on water hence the reading of the spring balance will increase.

4.12 (c)

$$T = 2\pi \sqrt{\frac{K_G^2}{g.GM}} = 2\pi \sqrt{\frac{(9)^2}{9.81 \times 0.750}} = 20.85 \text{ s}$$

4.13 (b)

Both **A** and **R** is true, but **R** does not give sufficient explanation for phenomenon at **A**. Location of metacenter and centre of buoyancy decide about floating of a body.

5.1 In a two-dimensional flow, the velocity components in x and y directions in terms of stream function (ψ) are

(a) $u = \frac{\partial \psi}{\partial x}; v = \frac{\partial \psi}{\partial y}$

(b) $u = \frac{\partial \psi}{\partial y}; v = \frac{\partial \psi}{\partial x}$

(c) $u = -\frac{\partial \psi}{\partial y}; v = \frac{\partial \psi}{\partial x}$

(d) $u = \frac{\partial \psi}{\partial x}; v = -\frac{\partial \psi}{\partial y}$

[ESE : 1995]

5.2 The differential form of continuity equation for two-dimensional flow of fluid may be written in the

following form $\rho \frac{\partial u}{\partial x} + \rho \frac{\partial v}{\partial y} = 0$ in which u and v

are velocities in the x and y -direction and ρ is the density. This is valid

- (a) for compressible, steady flow
 (b) for compressible, unsteady flow
 (c) for incompressible, unsteady flow
 (d) for incompressible, steady flow

[ESE : 1995]

5.3 Given that

u = velocity in the x -direction

v = velocity in the y -direction

A two-dimensional flow in x - y plane is irrotational if

(a) $\frac{\partial u}{\partial x} = \frac{\partial v}{\partial y}$

(b) $\frac{\partial u}{\partial x} = \frac{\partial u}{\partial y}$

(c) $\frac{\partial v}{\partial x} = \frac{\partial u}{\partial y}$

(d) $\frac{\partial v}{\partial x} = \frac{\partial v}{\partial y}$

[ESE : 1995]

5.4 Of the possible irrotational flow functions given below, the incorrect relation is (where ψ = stream function and ϕ = velocity potential)

(a) $\psi = xy$

(b) $\psi = A(x^2 - y^2)$

(c) $\phi = ur \cos \theta + \frac{u}{r} \cos \theta$

(d) $\phi = \left(r - \frac{2}{r}\right) \sin \theta$

[ESE : 1995]

5.5 Which one of the following statements is true to a two-dimensional flow of ideal fluids?

- (a) Potential function exists if stream function exists.
 (b) Stream function may or may not exist.
 (c) Both potential function and stream function must exist for every flow.
 (d) Stream function will exist but potential function may or may not exist.

[ESE : 1996]

5.6 The curl of a given velocity field ($\nabla \times \vec{V}$) indicates the rate of

- (a) increase or decrease of flow at a point
 (b) twisting of the lines of flow
 (c) deformation
 (d) translation

[ESE : 1996]

5.7 The general form of expression for the continuous equation in a cartesian co-ordinate system for incompressible or compressible flow is given by

(a) $\frac{\partial u}{\partial x} + \frac{\partial v}{\partial y} + \frac{\partial w}{\partial z} = 0$

(b) $\frac{\partial(\rho u)}{\partial x} + \frac{\partial(\rho v)}{\partial y} + \frac{\partial(\rho w)}{\partial z} = 0$

(c) $\frac{\partial \rho}{\partial t} + \frac{\partial(\rho u)}{\partial x} + \frac{\partial(\rho v)}{\partial y} + \frac{\partial(\rho w)}{\partial z} = 0$

(d) $\frac{\partial \rho}{\partial t} + \frac{\partial(\rho u)}{\partial x} + \frac{\partial(\rho v)}{\partial y} + \frac{\partial(\rho w)}{\partial z} = 1$

[ESE : 1996]

- 5.8 In a two-dimensional flow in x - y plane, if $\frac{\partial u}{\partial y} = \frac{\partial v}{\partial x}$, then the fluid element will undergo
- translation only
 - translation and rotation
 - translation and deformation
 - rotation and deformation [ESE : 1996]
- 5.9 For an irrotational flow, the velocity potential lines and the streamlines are always
- parallel to each other
 - coplanar
 - orthogonal to each other
 - inclined to the horizontal [ESE : 1997]
- 5.10 Irrotational flow occurs when
- flow takes place in a duct of uniform cross-section at constant mass flow rate
 - streamlines are curved
 - there is no net rotation of the fluid element about its mass centre
 - fluid element does not undergo any change in size or shape [ESE : 1998]
- 5.11 If the stream function is given by $\psi = 3xy$, then the velocity at a point (2, 3) will be
- 7.21 unit
 - 10.82 unit
 - 18 unit
 - 54 unit [ESE : 1998]

- 5.12 The area of a 2 m long tapered duct decreases as $A = (0.5 - 0.2x)$ where 'x' is the distance in meters. At a given instant a discharge of $0.5 \text{ m}^3/\text{s}$ is flowing in the duct and is found to increase at a rate of $0.2 \text{ m}^3/\text{s}$. The local acceleration (in m/s^2) at $x = 0$ will be
- 1.4
 - 1.0
 - 0.4
 - 0.667 [ESE : 1998]

- 5.13 Match List-I (Pipe flow) with List-II (Types of acceleration) and select the correct answer using the codes given below the lists:

List-I

- Flow at constant rate passing through a bend
- Flow at constant rate passing through a straight uniform diameter pipe
- Gradually changing flow through a bend
- Gradually changing flow through a straight pipe

List-II

- Zero acceleration
- Local and convective acceleration
- Convective acceleration
- Local acceleration

Codes:

	A	B	C	D
(a)	3	1	2	4
(b)	3	1	4	2
(c)	1	3	2	4
(d)	1	3	4	2

[ESE : 1999]

Answers Fluid Kinematics

- 5.1 (c) 5.2 (d) 5.3 (c) 5.4 (c) 5.5 (d) 5.6 (c) 5.7 (c) 5.8 (c) 5.9 (c)
5.10 (c) 5.11 (b) 5.12 (c) 5.13 (a)

Explanations Fluid Kinematics

5.1 (c)

The stream function (ψ) is defined as a scalar function of space and time, such that its partial derivative with respect to any direction gives the velocity component at right angles (in the counterclockwise direction) to this direction.

$$\therefore \frac{\partial \psi}{\partial y} = -u; \quad \frac{\partial \psi}{\partial x} = v$$

5.2 (d)

Continuity equation for two-dimensional steady flow

$$\frac{\partial(\rho u)}{\partial x} + \frac{\partial(\rho v)}{\partial y} = 0$$

Further for an incompressible fluid the mass density ρ does not change with x , y and t and hence equation simplifies to

$$\rho \frac{\partial u}{\partial x} + \rho \frac{\partial v}{\partial y} = 0$$

5.3 (c)

Irrotational flow: If the fluid particle don't rotate about their mass centre while moving in the direction of motion, the flow is called as irrotational flow eg. free vortex.

$$\omega = \frac{1}{2} \left[\frac{\partial v}{\partial x} - \frac{\partial u}{\partial y} \right] = 0$$

$$\therefore \frac{\partial v}{\partial x} = \frac{\partial u}{\partial y}$$

5.4 (c)

If the stream function satisfy the Laplace equation the flow is irrotational, otherwise rotational.

If $\frac{\partial^2 \psi}{\partial x^2} + \frac{\partial^2 \psi}{\partial y^2} = 0$ (Laplace equation)

then $\omega_z = 0$

A. $\psi = xy$

$$\frac{\partial^2 \psi}{\partial x^2} + \frac{\partial^2 \psi}{\partial y^2} = \frac{\partial^2(xy)}{\partial x^2} + \frac{\partial^2(xy)}{\partial y^2}$$

$$= 0 + 0 = 0$$

Satisfy the Laplace equation therefore flow is irrotational.

B. $\psi = A(x^2 - y^2)$

$$\frac{\partial^2 \psi}{\partial x^2} + \frac{\partial^2 \psi}{\partial y^2} = \frac{\partial^2[A(x^2 - y^2)]}{\partial x^2} + \frac{\partial^2[A(x^2 - y^2)]}{\partial y^2}$$

$$= 2A - 2A = 0$$

Satisfy Laplace equation, therefore flow is rotational.

C. $\nabla^2 \phi = 0$

$$\left. \begin{aligned} V_r &= -\frac{\partial \phi}{\partial r} \\ V_\theta &= -\frac{1}{r} \frac{\partial \phi}{\partial \theta} \end{aligned} \right\} \text{Cylindrical coordinate}$$

$$2w_z = \frac{1}{r} \frac{\partial}{\partial r} \left[-\frac{1}{r} \frac{\partial \phi}{\partial \theta} \right] - \frac{1}{r^2} \frac{\partial}{\partial \theta} \left[-\frac{\partial \phi}{\partial r} \right]$$

$$\phi = ur \cos \theta + \frac{u}{r} \cos \theta$$

$$V_r = -\frac{\partial \phi}{\partial r} = -u \cos \theta + \frac{u}{r^2} \cos \theta$$

$$V_\theta = -\frac{1}{r} \frac{\partial \phi}{\partial \theta}$$

$$= -\frac{1}{r} \left[-ur \sin \theta - \frac{u}{r} \sin \theta \right]$$

$$V_\theta = u \sin \theta + \frac{u}{r^2} \sin \theta$$

$$2w_z = \frac{1}{r} \frac{\partial}{\partial r} \left[u \sin \theta + \frac{u}{r^2} \sin \theta \right] - \frac{1}{r^2} \frac{\partial}{\partial \theta} \left[-u \cos \theta + \frac{u}{r^2} \cos \theta \right]$$

$$= \frac{1}{r} \left(-\frac{2u}{r^3} \sin \theta \right) - \frac{1}{r^2} \left[-u \sin \theta + \frac{u}{r^2} \sin \theta \right]$$

$$= -\frac{2u \sin \theta}{r^4} - \frac{u \sin \theta}{r^2} + \frac{u}{r^4} \sin \theta$$

D. $\phi = \left(r - \frac{2}{r} \right) \sin \theta$

$$V_r = -\frac{\partial \phi}{\partial r} = -\left[1 + \frac{2}{r^2} \right] \sin \theta$$

$$V_\theta = -\frac{1}{r} \frac{\partial \phi}{\partial \theta} = -\frac{1}{r} \left[r - \frac{2}{r} \right] \cos \theta$$

$$= -\left[1 - \frac{2}{r^2} \right] \cos \theta$$

$$2D : \frac{1}{r} \frac{\partial}{\partial r} (r V_r) + \frac{1}{r} \frac{\partial}{\partial \theta} (V_\theta)$$

$$= \frac{1}{r} \frac{\partial}{\partial r} \left[\left(-r - \frac{2}{r} \right) \sin \theta \right] +$$

$$\frac{1}{r} \frac{\partial}{\partial \theta} \left[-\left(-1 - \frac{2}{r} \right) \cos \theta \right]$$

$$= \frac{1}{r} \left(-1 - \frac{2}{r^2} \right) \sin \theta + \frac{1}{r} \times \left(1 - \frac{2}{r} \right) \sin \theta$$

$$= \frac{2}{r} \left[-1 + \frac{2}{r^2} \right] = 0$$

5.5 (d)

Stream function exists only for 2-D flow.
Potential function exists only for irrotational flow.

5.6 (c)

The curl indicates the rate of deformation.

5.7 (c)

Continuity equation for compressible or non-compressible fluid is

$$\frac{\partial(\rho u)}{\partial x} + \frac{\partial(\rho v)}{\partial y} + \frac{\partial(\rho w)}{\partial z} + \frac{\partial \rho}{\partial t} = 0$$

5.8 (c)

Irrotational flow: If the fluid particle don't rotate about their mass centre while moving in the direction of motion, the flow is called as irrotational flow eg. free vortex.

$$\omega = \frac{1}{2} \left[\frac{\partial v}{\partial x} - \frac{\partial u}{\partial y} \right] = 0$$

$$\therefore \frac{\partial v}{\partial x} = \frac{\partial u}{\partial y}$$

5.9 (c)

$$\text{Slope of velocity potential} = \left(\frac{dy}{dx} \right)_1 = -\frac{u}{v}$$

$$\text{Slope of stream line} \left(\frac{dy}{dx} \right)_2 = \frac{v}{u}$$

$$\left(\frac{dy}{dx} \right)_1 \times \left(\frac{dy}{dx} \right)_2 = -\frac{u}{v} \times \frac{v}{u} = -1$$

Hence, they are orthogonal to each other.

5.10 (c)

If the fluid particles do not rotate about their mass centre & while moving in the direction of motion. The flow is called as an irrotational flow.

5.11 (b)

$$\frac{\partial \psi}{\partial x} = v = 3y$$

$$\frac{\partial \psi}{\partial y} = -u = 3x$$

$$\vec{V} = -3x\hat{i} + 3y\hat{j}$$

At (2, 3)

$$\vec{V} = -6\hat{i} + 9\hat{j}$$

$$|\vec{V}| = \mathbf{10.82 \text{ units}}$$

5.12 (c)

Local acceleration.

$$\frac{\partial v}{\partial t} = \frac{\partial}{\partial t} \left(\frac{Q}{A} \right) = \frac{1}{A} \frac{\partial Q}{\partial t}$$

$$\left. \frac{\partial v}{\partial t} \right|_{x=0} = \frac{0.2}{0.5} = \mathbf{0.4}$$

5.13 (a)

- (a) Flow at constant rate passing through a bend : Convective acceleration
- (b) Flow at constant rate passing through a straight uniform diameter pipe : Zero acceleration
- (c) Gradually changing flow through a bend : Local and convective acceleration
- (d) Gradually changing flow through a straight pipe : Local acceleration

■■■■

6

Fluid Dynamics and Flow Measurement

- 6.1 Prandtl Pitot tube was used to measure the velocity of a fluid of specific gravity S_1 . The differential manometer, with a fluid of specific gravity S_2 connected to the Pitot tube recorded a level difference as h as shown in figure below.

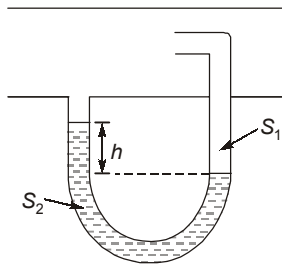

The velocity V is given by the expression

- (a) $\sqrt{2gh\left(\frac{S_1}{S_2} - 1\right)}$ (b) $\sqrt{2gh\left(\frac{S_2}{S_1} - 1\right)}$
 (c) $\sqrt{2gh(S_1 - S_2)}$ (d) $\sqrt{2gh(S_2 - S_1)}$

[ESE : 1995]

- 6.2 The expression $\left(\rho + \rho gz + \frac{\rho V^2}{2}\right)$ commonly used

to express Bernoulli's equation, has units of total energy per unit

- (a) mass
 (b) weight
 (c) volume
 (d) cross-sectional area of flow

[ESE : 1995]

- 6.3 If calibration chart is prepared for a hot-wire anemometer for measuring the mean velocities, the highest level of accuracy can be

- (a) equal to accuracy of a Pitot tube
 (b) equal to accuracy of a rotameter
 (c) equal to accuracy of a venturimeter
 (d) more than that of all the three instruments mentioned above

[ESE : 1996]

- 6.4 The predominant forces acting on an element of fluid in the boundary layer over a flat plate placed in a uniform stream include

- (a) inertia and pressure forces
 (b) viscous and pressure forces
 (c) viscous and body forces
 (d) viscous and inertia forces

[ESE : 1996]

- 6.5 Given that

H = height of liquid,
 b = width of notch,
 a = cross-sectional area,
 a_1 = area at inlet,
 a_2 = area at the throat, and
 C_d = coefficient of discharge

Match **List-I** with **List-II** and select the correct answer using the codes given below the lists:

List-I

- A. Discharge through venturimeter
 B. Discharge through an external mouthpiece
 C. Discharge over a rectangular notch
 D. Discharge over right angled notch

List-II

1. $\frac{2}{3} C_d b \sqrt{2gH}^{3/2}$
 2. $\frac{8}{15} C_d \sqrt{2gH}^{5/2}$
 3. $\frac{C_d a_1 a_2}{\sqrt{a_1^2 - a_2^2}} \sqrt{2gH}$
 4. $0.855 a \sqrt{2gH}$

Codes:

- | | A | B | C | D |
|-----|---|---|---|---|
| (a) | 1 | 2 | 3 | 4 |
| (b) | 3 | 4 | 1 | 2 |
| (c) | 2 | 1 | 3 | 4 |
| (d) | 2 | 3 | 1 | 4 |

[ESE : 1997]

6.6 Match **List-I** (Measuring device) with **List-II** (Parameters) regarding a body partly submerged in a liquid and select the correct answer using the codes given below the lists:

List-I

- A.** Anemometer
B. Piezometer
C. Pitot tube
D. Orifice

List-II

- 1.** Flow rate
2. Velocity
3. Static pressure
4. Difference between static and stagnation pressure

Codes:

	A	B	C	D
(a)	1	3	4	2
(b)	1	2	3	4
(c)	2	3	4	1
(d)	2	4	3	1

[ESE : 1997]

6.7 Assertion (A): Bernoulli's equation is an energy equation.

Reason (R): Starting from Euler's equation, one can arrive at Bernoulli's equation.

- (a) Both **A** and **R** are individually true and **R** is the correct explanation of **A**

(b) Both **A** and **R** are individually true but **R** is not the correct explanation of **A**

(c) **A** is true but **R** is false

(d) **A** is false but **R** is true [ESE : 1997]

6.8 Consider the following assumptions:

1. The fluid is compressible.
2. The fluid is inviscid.
3. The fluid is incompressible and homogeneous.
4. The fluid is viscous and compressible.

The Euler's equation of motion requires assumptions indicated in

(a) 1 and 2

(b) 2 and 3

(c) 1 and 4

(d) 3 and 4

[ESE : 1998]

6.9 A horizontal pipe of cross-sectional area 5 cm^2 is connected to a venturimeter of throat area 3 cm^2 as shown in the figure below. The manometer reading is equivalent to 5 cm of water.

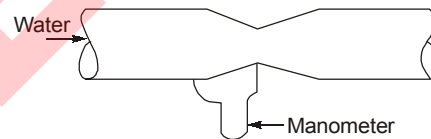

The discharge is nearly

(a) $0.45 \text{ cm}^3/\text{s}$

(b) $5.5 \text{ cm}^3/\text{s}$

(c) $21.0 \text{ cm}^3/\text{s}$

(d) $370 \text{ cm}^3/\text{s}$

[ESE : 1998]

■■■■

Answers Fluid Dynamics and Flow Measurement

6.1 (b) **6.2** (c) **6.3** (d) **6.4** (d) **6.5** (b) **6.6** (c) **6.7** (a) **6.8** (b) **6.9** (d)

Explanations Fluid Dynamics and Flow Measurement

6.1 (b)

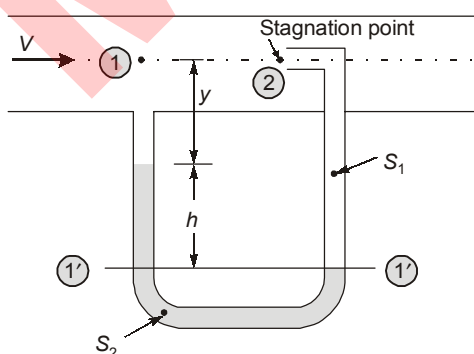

Let $1'-1'$ be the datum line

Pressure in the left limb above datum line

= Pressure in the right limb above datum line

$$p_1 + \rho_1 g y + \rho_2 g h = p_2 + \rho_1 g (h + y)$$

$$\text{or } p_2 - p_1 = \rho_2 g h - \rho_1 g h = \rho g h \left(\frac{\rho_2}{\rho_1} - 1 \right)$$

$$\text{or } \frac{p_2 - p_1}{\rho_1 g} = h \left(\frac{\rho_2}{\rho_1} - 1 \right) \quad \dots (i)$$

Applying Bernoulli's equation between points 1 and 2

$$\frac{p_1}{\rho_1 g} + \frac{V_1^2}{2g} + z_1 = \frac{p_2}{\rho_1 g} + \frac{V_2^2}{2g} + z_2$$

$$\frac{p_1}{\rho_1 g} + \frac{V_1^2}{2g} = \frac{p_2}{\rho_1 g} \quad \because V_2 = 0, z_1 = z_2$$

$$\text{or} \quad \frac{p_2 - p_1}{\rho_1 g} = \frac{V_1^2}{2g} \quad \dots \text{(ii)}$$

Equating Eqs. (i) and (ii)

$$\frac{V_1^2}{2g} = h \left(\frac{p_2}{p_1} - 1 \right)$$

$$V_1^2 = 2gh \left(\frac{p_2}{p_1} - 1 \right)$$

$$V_1 = \sqrt{2gh \left(\frac{S_2}{S_1} - 1 \right)}$$

$$\therefore \frac{p_2}{p_1} = \frac{1000 \times S_2}{1000 \times S_1} = \frac{S_2}{S_1}$$

6.2 (c)

The expression $\left(\rho + \rho gz + \frac{\rho V^2}{2} \right)$, has units of total energy per unit volume.

6.4 (d)

Reynolds number is used to characterize flow regimes, such as laminar flow and turbulent flow. It gives measure of the ratio of inertial force to viscous force. It consequently quantifies the importance of boundary layer concept.

6.5 (b)

(a) Discharge through venturimeter,

$$Q = \frac{C_d a_1 a_2}{\sqrt{a_1^2 - a_2^2}} \sqrt{2gh}$$

(b) Discharge through an external mouthpiece

$$Q = 0.855a\sqrt{2gH}$$

(c) Discharge over a rectangular notch

$$Q = \frac{2}{3} C_d b \sqrt{2gH^3}$$

(d) Discharge over right angled notch

$$Q = \frac{8}{15} C_d \sqrt{2g} H^{5/2}$$

6.6 (c)

Anemometer: It is device for measuring wind speed, and it a common weather station instrument.

Orifice plate: It is a device used for measuring the volumetric flow. It uses the Bernoulli's principle.

6.7 (a)

Assumptions made in Euler's equation

1. Steady flow
2. Flow is non-viscous

$$\frac{dp}{\rho} + g dz + v dv = 0 \quad \text{(Euler equation)}$$

Integrating

$$\int \frac{dp}{\rho} + \int g dz + \int v dv = \int 0$$

Assuming-incompressible flow (ρ -constant)

$$\frac{1}{\rho} \int dp + g \int dz + \int v dv = \int 0$$

$$\frac{p}{\rho} + gz + \frac{v^2}{2} = \text{constant} \quad \text{[Bernoulli's equation]}$$

6.8 (b)

Euler's equation of motion are applicable to incompressible, non viscous fluids in steady or unsteady state of flow.

6.9 (d)

Given data: $A = 5 \text{ cm}^2$, $a = 3 \text{ cm}^2$
 $h = 5 \text{ cm}$ of water

$$\text{Discharge, } Q = \frac{C_d A a \sqrt{2gh}}{\sqrt{A^2 - a^2}} \text{ cm}^3/\text{s}$$

where, $C_d = 1$ (assume); h is in cm
 A and a are in cm^2

$$g = 981 \text{ cm/s}^2$$

$$\therefore Q = \frac{1 \times 5 \times 3 \times \sqrt{2 \times 981 \times 5}}{\sqrt{(5)^2 - (3)^2}} \\ = 371.42 \text{ cm}^3/\text{s} \approx 370 \text{ cm}^3/\text{s}$$

■■■■

7.1 If H is the total head at inlet and h is the head lost due to friction, efficiency of power transmission through a straight pipe is given by

- (a) $\frac{H-h}{H}$ (b) $\frac{H}{H+h}$
 (c) $\frac{H-h}{H+h}$ (d) $\frac{H}{H-h}$

[ESE : 1995]

7.2 Water hammer in pipelines takes place when
 (a) fluid is flowing with high velocity
 (b) fluid is flowing with high pressure
 (c) flowing fluid is suddenly brought to rest by closing a valve
 (d) flowing fluid is brought to rest by gradually closing a valve

[ESE : 1995]

7.3 **Assertion (A):** There will be a redistribution of pressure and velocity from inside of the bend to the outside while a fluid flows through a pipe bend.

Reason (R): The spacing between stream lines will increase towards the outside wall and decrease towards the inside wall to inside of the bend.

- (a) Both **A** and **R** are individually true and **R** is the correct explanation of **A**
 (b) Both **A** and **R** are individually true but **R** is not the correct explanation of **A**
 (c) **A** is true but **R** is false
 (d) **A** is false but **R** is true

[ESE : 1995]

7.4 All experiments thus far indicate that there can be a laminar flow in a pipe if the Reynolds number is below

- (a) 2300 (b) 4000
 (c) 2000 (d) 40000

[ESE : 1996]

7.5 Water flow through a pipeline having four different diameters at 4 stations is shown in the figure below.

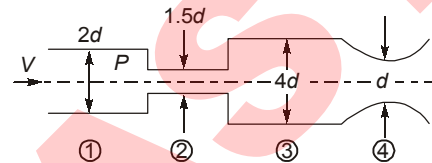

The correct sequence of station numbers in the decreasing order of pressure is

- (a) 3, 1, 4, 2 (b) 1, 3, 2, 4
 (c) 1, 3, 4, 2 (d) 3, 1, 2, 4

[ESE : 1996]

7.6 During the measurement of viscosity of air flowing through a pipe, we use the relation

$$\mu = \frac{\pi d^4}{128Q} \left(-\frac{dp}{dx} \right)$$

under the condition that in the

measuring section

- (a) there is a viscous zone near the wall and an inviscid core persists at the centre
 (b) the entire cross-section is viscous
 (c) the flow can be assumed as potential flow
 (d) the flow is irrotational

[ESE : 1996]

7.7 If the energy grade line and hydraulic grade line are drawn for flow through an inclined pipeline the following four quantities can be directly observed:

1. Static head
2. Friction head
3. Datum head
4. Velocity head

Starting from the arbitrary datum line, the above types of heads will be in the sequence

- (a) 3, 2, 1, 4 (b) 3, 4, 2, 1
 (c) 3, 4, 1, 2 (d) 3, 1, 4, 2

[ESE : 1996]

- 7.8** Hydrodynamic entrance length for
- (a) laminar flow is greater than that for turbulent flow
 - (b) turbulent flow is greater than that for laminar flow
 - (c) laminar flow is equal to that for turbulent flow
 - (d) a given flow can be determined only if the Prandtl number is known

[ESE : 1996]

- 7.9** Which one of the following statements is true for fully developed flow through pipes?
- (a) The flow is parallel, has no inertia effects, the pressure gradient is of constant value and the pressure force is balanced by the viscous force
 - (b) The flow is parallel, the pressure gradient is proportional to the inertia force and there is no viscous effect
 - (c) The flow is parallel, the pressure gradient is negligible and the inertia force is balanced by the viscous force
 - (d) The flow is not parallel, the core region accelerates and the viscous drag is far too less than the inertia force

[ESE : 1997]

7.10 Assertion (A): In the case of flow around pipe bends, there will be redistribution of pressure and velocity from inside bend to the outside bend.

Reason (R): Flow will be such that the stream line spacing will decrease towards the inner bend resulting in decrease of pressure head and increase of velocity head at the inner wall.

- (a) Both **A** and **R** are individually true and **R** is the correct explanation of **A**
- (b) Both **A** and **R** are individually true but **R** is not the correct explanation of **A**
- (c) **A** is true but **R** is false
- (d) **A** is false but **R** is true

[ESE : 1997]

7.11 A pipe flow system with flow direction is shown in figure below:

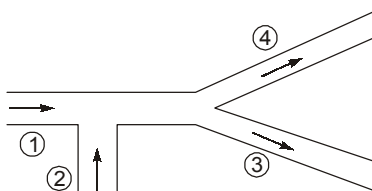

The following table gives the velocities and the corresponding areas:

Pipe No.	Area (cm) ²	Velocity (cm/s)
1.	50	10
2.	50	V_2
3.	80	5
4.	70	5

The value of V_2 is

- (a) 2.5 cm/s
- (b) 5.0 cm/s
- (c) 7.5 cm/s
- (d) 10.0 cm/s

[ESE : 1998]

7.12 A liquid flows downward through a tapered vertical portion of a pipe. At the entrance and exit of the pipe, the static pressures are equal. If for a vertical height ' h ' the velocity becomes four times, then the ratio of ' h ' to the velocity head at entrance will be

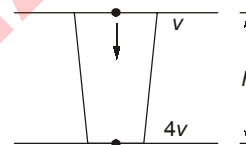

- (a) 3
- (b) 8
- (c) 15
- (d) 24

[ESE : 1998]

7.13 The equivalent length of the stepped pipeline shown in the figure below, can be expressed in terms of the diameter D as

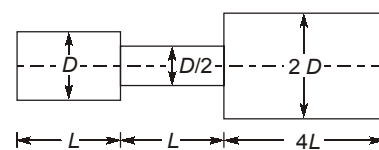

- (a) $5.25 L$
- (b) $9.5 L$
- (c) $33 \frac{1}{32} L$
- (d) $33 \frac{1}{8} L$

[ESE : 1998]

7.14 The pipe cross-sections and fluid flow rates are shown in the figure below.

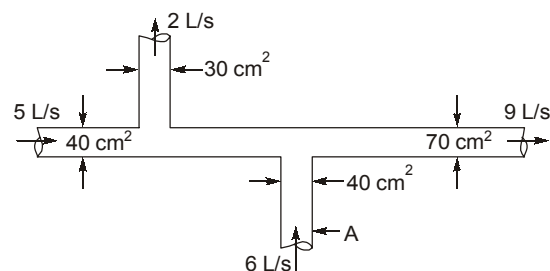

The velocity in the pipe labelled as (A) is

- (a) 1.5 m/s
- (b) 3 m/s
- (c) 15 m/s
- (d) 30 m/s

[ESE : 1999]

7.15 The elbow nozzle assembly shown in the Figure below is in a horizontal plane. The velocity of jet issuing from the nozzle is

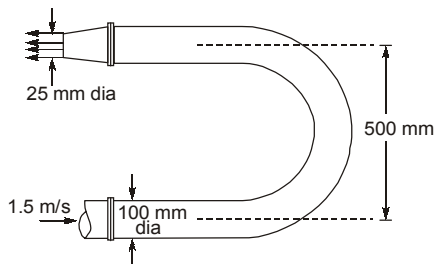

- (a) 4 m/s
- (b) 16 m/s
- (c) 24 m/s
- (d) 30 m/s

[ESE : 1999]

7.16 Point A of head H_A is at a higher elevation than point B of head H_B . The head loss between these points is H_L . The flow will take place

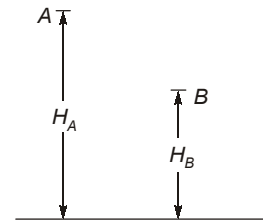

- (a) always from A to B
- (b) from A to B if $H_A = H_B + H_L$
- (c) from B to A if $H_A + H_L = H_B$
- (d) from B to A if $H_B + H_L = H_A$

[ESE : 1999]

7.17 The value of friction factor is misjudged by +25% in using Darcy-Weisbach equation. The resulting error in the discharge will be

- (a) +25%
- (b) -18.25%
- (c) -12.5%
- (d) +12.5%

[ESE : 1999]

■■■■

Answers Flow Through Pipes

- 7.1 (a) 7.2 (c) 7.3 (a) 7.4 (c) 7.5 (d) 7.6 (b) 7.7 (d) 7.8 (a) 7.9 (a)
 7.10 (a) 7.11 (b) 7.12 (c) 7.13 (d) 7.14 (a) 7.15 (c) 7.16 (b) 7.17 (c)

Explanations Flow Through Pipes

7.1 (a)

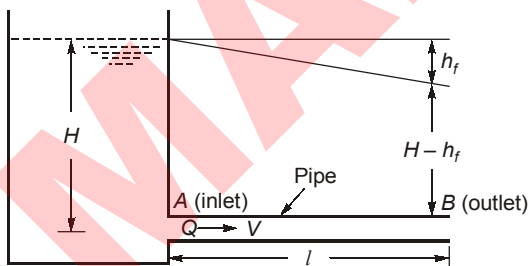

H = Head at inlet of pipe
 h_f = Head lost due to friction
 $H - h_f$ = Head available at outlet of pipe

Power at pipe inlet,

$$P_i = \rho QgH$$

Power at pipe outlet,

$$P_o = \rho Qg(H - h_f)$$

Efficiency,
$$\eta = \frac{P_o}{P_i} = \frac{\rho Qg(H - h_f)}{\rho QgH} = \frac{H - h_f}{H}$$

7.2 (c)

When the water flowing in a long pipe is suddenly brought to rest by closing the valve or by any similar cause, there will be sudden rise in pressure due to the momentum of the moving water being destroyed. This causes a wave of high pressure to be transmitted along the pipe which creates noise known as knocking. This phenomenon of sudden rise in pressure in the pipe is known as water hammer or hammer blow.

7.4 (c)

For pipe flow

$Re < 2000$ (Laminar flow)

$2000 < Re < 4000$ (Transition flow)

$Re > 4000$ (Turbulent flow)

7.5 (d)

Pressure is least where velocity is highest and at larger cross-section for constant discharge, velocity lowers.

7.7 (d)

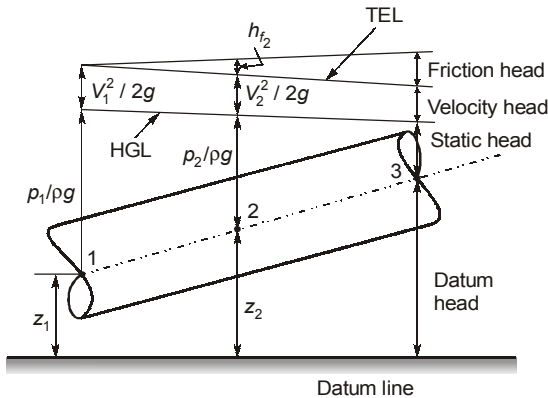

7.8 (a)

Hydrodynamic entrance length is the distance from the entrance of a channel to the point where the flow become hydrodynamically fully developed.

7.9 (a)

For fully developed flow through pipes, the flow is parallel, has no inertia effect. The pressure gradient is of constant value and the pressure force is balanced by the viscous force.

7.11 (b)

Total discharge

$$Q_1 + Q_2 = Q_3 + Q_4$$

$$\Rightarrow 50 \times 10 + 50 \times V_2 = 80 \times 5 + 70 \times 5$$

$$\therefore V_2 = 5 \text{ cm/s}$$

7.12 (c)

By Bernoulli's equation,

$$\frac{V_1^2}{2g} + h = \frac{16V_1^2}{2g}$$

$$\therefore h = 15 \frac{V_1^2}{2g}$$

$$\frac{h}{V_1^2 / 2g} = 15$$

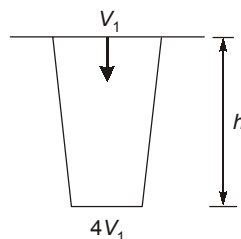

7.13 (d)

$$Q_L = Q_1 + Q_2 + Q_3$$

$$\frac{fL_{eq}Q^2}{12.1D^5} = \frac{fLQ^2}{12.1D^5} + \frac{fLQ^2}{12.1\left(\frac{D}{2}\right)^5} + \frac{f_x Q^2 \times 4L}{12.1(2D)^5}$$

$$\frac{L_{eq}}{D^5} = \frac{L}{D^5} + \frac{32L}{D^5} + \frac{L}{8D^5}$$

$$\therefore L_{eq} = L + 32L + \frac{L}{8} = 33 \frac{1}{8} L$$

7.14 (a)

$$V = \frac{Q}{A} = \frac{6 \times 10^{-3}}{40 \times 10^{-4}} = 1.5 \text{ m/s}$$

7.15 (c)

$$1.5 \times \frac{\pi}{4} \times (0.1)^2 = \frac{\pi}{4} \times (0.025)^2 \times V$$

$$\therefore V = 24 \text{ m/s}$$

7.16 (b)

The flow will take from higher elevation to lower elevation provided the difference in total head is greater than the head loss taking place during the flow.

7.17 (c)

As per Darcy-Weisbach equation

$$h_f = \frac{4fl}{2gd} \times \frac{16Q^2}{\pi^2 d^2}$$

i.e. $Q \propto \sqrt{\frac{1}{f}}$

If f is misjudged by +25%, new Q will be proportional to $\sqrt{\frac{1}{1.25}}$ i.e. 89%
i.e. it is reduced about 11%.



- 8.1** The parameters for ideal fluid flow around a rotating circular cylinder can be obtained by superposition of some elementary flows. Which one of the following sets would describe the flow around a rotating circular cylinder?
- (a) Doublet, vortex and uniform flow
 (b) Source, vortex and uniform flow
 (c) Sink, vortex and uniform flow
 (d) Vortex and uniform flow [ESE : 1997]
- 8.2** An inviscid, irrotational flow field of free vortex motion has a circulation constant Ω . The tangential velocity at any point in the flow field is given by Ω/r , where r , is the radial distance from the centre. At the centre, there is a mathematical singularity which can be physically substituted by a forced vortex. At the interface of the free and forced vortex motion ($r = r_c$), the angular velocity ω is given by
- (a) $\frac{\Omega}{r_c^2}$ (b) $\frac{\Omega}{r_c}$
 (c) Ωr_c (d) Ωr_c^2 [ESE : 1997]
- 8.3** A right circular cylinder, open at the top is filled with liquid of relative density 1.2. It is rotated about its vertical axis at such a speed that half the liquid spills out. The pressure at the centre of the bottom will be
- (a) zero
 (b) one-fourth of the value when the cylinder was full
 (c) half of the value when the cylinder was full
 (d) not determinable from the given data [ESE : 1998]
- 8.4 Assertion (A):** A cylinder, partly filled with a liquid, is rotated about its vertical axis. The rise of liquid level at the ends is equal to the fall of liquid level at the axis.
- Reason (R):** Rotation creates forced vortex motion.
- (a) Both **A** and **R** are individually true and **R** is the correct explanation of **A**
 (b) Both **A** and **R** are individually true but **R** is not the correct explanation of **A**
 (c) **A** is true but **R** is false
 (d) **A** is false but **R** is true [ESE : 1999]

Answers Vortex Flow

- 8.1 (a) 8.2 (a) 8.3 (a) 8.4 (b)

Explanations Vortex Flow

8.2 (a)

Free vortex,

$$Vr = \text{constant} = \Omega \text{ (given)}$$

$$v = \frac{\Omega}{r}$$

Forced vortex,

$$v = r\omega$$

$$\omega = \frac{v}{r}$$

$$r = r_c$$

$$v = \frac{\Omega}{r_c}$$

(Free vortex)

$$\omega = \frac{v}{r_c}$$

(Forced vortex)

$$\omega = \frac{\left(\frac{\Omega}{r_c}\right)}{r_c} = \frac{\Omega}{r_c^2}$$

8.3 (a)

When cylinder is rotated such that half of the liquid spills out. Then liquid left in cylinder at height

$$\frac{Z}{2}$$

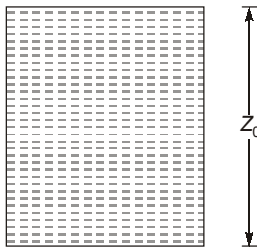

Initial condition

and liquid will rise at the wall of the cylinder by the same amount as it falls at the centre from its original level at rest.

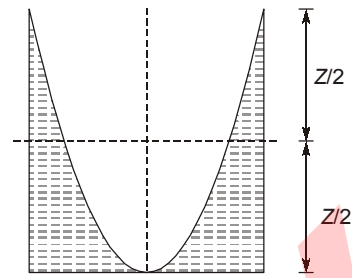

Final Condition

8.4 (b)

Both **A** and **B** are true. But **R** is not satisfactory explanation for **A**. The liquid rise up the wall is same as liquid fall at centre because the volume of a paraboloid of revolution is equal to half the volume of the cylinder circumscribing the paraboloid.



MADE EASY

9

Laminar Flow

9.1 For fully developed laminar flow through a pipe the volumetric flow is given by (symbols have the usual meaning)

- (a) $\frac{\pi}{8\mu}R^4\left(-\frac{dp}{dz}\right)$ (b) $\frac{\pi}{4\mu}R^4\left(-\frac{dp}{dz}\right)$
 (c) $\frac{\pi}{32\mu}R^4\left(-\frac{dp}{dz}\right)$ (d) $\frac{\pi}{16\mu}R^4\left(-\frac{dp}{dz}\right)$

[ESE : 1995]

9.2 Which one of the following velocity distributions of u/U_∞ satisfies the boundary conditions for laminar flow on a flat plate? (Here U_∞ is the free stream velocity, u is velocity at any normal distance y from the flat plate, $\eta = y/\delta$ and δ is boundary layer thickness)

- (a) $\eta - \eta^2$ (b) $1.5\eta - 0.5\eta^3$
 (c) $3\eta - \eta^2$ (d) $\cos(\pi\eta/2)$

[ESE : 1996]

Direction: Each of the next questions consists of two statements, one labelled as the 'Assertion (A)' and the other as 'Reason (R)'. You are to examine these two statements carefully and select the answers to these items using the codes given below:

Codes:

- (a) Both **A** and **R** are individually true and **R** is the correct explanation of **A**
 (b) Both **A** and **R** are individually true but **R** is not the correct explanation of **A**
 (c) **A** is true but **R** is false
 (d) **A** is false but **R** is true

9.3 **Assertion (A):** Nature of the fluid flow in pipe does not depend entirely on average velocity but is actually a function of the Reynolds number.

Reason (R): Reynolds number depends not only on average velocity but also on the diameter of the pipe and kinematic viscosity of the fluid.

[ESE : 1995]

9.4 **Assertion (A):** For a fully developed viscous flow through a pipe the velocity distribution across any section is parabolic in shape.

Reason (R): The shear stress distribution from the centre line of pipe upto the pipe surface increases linearly.

[ESE : 1996]



Answers Laminar Flow

9.1 (a) 9.2 (b) 9.3 (a) 9.4 (a)

Explanations Laminar Flow

9.1 (a)

For steady laminar flow through a circular pipe velocity

$$U = \frac{1}{4\mu} \left(-\frac{\partial p}{\partial z} \right) (R^2 - r^2)$$

The discharge Q passing through any cross-section

$$dQ = U dA = U(2\pi r) dr$$

$$= \frac{\pi}{4\mu} \left(-\frac{\partial p}{\partial z} \right) (R^2 - r^2) (2\pi r) dr$$

By integration

$$Q = \frac{\pi}{2\mu} \left(-\frac{\partial p}{\partial z} \right) \int_0^R (R^2 - r^2) dr$$

$$Q = \frac{\pi}{8\mu} \left(-\frac{\partial p}{\partial z} \right) R^4$$

9.2 (b)

For laminar flow $\left. \frac{\partial u}{\partial y} \right|_{y=\delta} = 0$

Equation (b) only satisfied this equation.

9.3 (a)

Reynold's number decides the fluid flow is laminar or turbulent, i.e. Nature of fluid flow.

$$Re = \frac{\rho VD}{\mu}$$

9.4 (a)

For laminar flow through a circular pipe (Radius R)

Shear stress distribution $\tau = \left(-\frac{\partial p}{\partial x} \right) \frac{r}{2}$

i.e. $\tau \propto r$ (linear variation)

Velocity distribution,

$$\begin{aligned} u &= \frac{1}{4\mu} \left(-\frac{\partial p}{\partial x} \right) R^2 \left[1 - \frac{r^2}{R^2} \right] \\ &= U_{\max} \left(1 - \frac{r^2}{R^2} \right) \quad (\text{Parabolic Profile}) \end{aligned}$$

where

$$U_{\max} = \frac{1}{4\mu} \left(-\frac{\partial p}{\partial x} \right) R^2$$

This velocity distribution is derived from linear stress profile

$$\tau = -\mu \frac{du}{dr} = \left(-\frac{\partial p}{\partial x} \right) \frac{r}{2}$$

$$\Rightarrow \frac{1}{2\mu} \left(\frac{\partial p}{\partial x} \right) r dr = du$$

$$\text{Integrating } \frac{1}{2\mu} \left(\frac{\partial p}{\partial x} \right) \frac{r^2}{2} + c = u \quad \dots(1)$$

Boundary conditions

At $r = R, u = 0$ (Fixed plate/pipe)

$$\frac{1}{2\mu} \left(\frac{\partial p}{\partial x} \right) \frac{R^2}{2} + c = 0$$

$$c = -\frac{1}{2\mu} \left(\frac{\partial p}{\partial x} \right) \frac{R^2}{2}$$

Putting constant c in Eq. (1)

$$\left\{ \frac{1}{2\mu} \left(\frac{\partial p}{\partial x} \right) \frac{r^2}{2} \right\} + \left\{ -\frac{1}{2\mu} \left(\frac{\partial p}{\partial x} \right) \frac{R^2}{2} \right\} = u$$

$$\Rightarrow u = \frac{1}{4\mu} \left(-\frac{\partial p}{\partial x} \right) [R^2 - r^2]$$

$$\Rightarrow u = \frac{1}{4\mu} \left(-\frac{\partial p}{\partial x} \right) R^2 \left[1 - \frac{r^2}{R^2} \right]$$

Parabolic distribution of velocity. ■■■■

10.1 The frictional head loss in a turbulent flow through a pipe varies

- (a) directly as the average velocity
- (b) directly as the square of the average velocity
- (c) inversely as the square of the average velocity
- (d) inversely as the square of the internal diameter of the pipe

[ESE : 1995]

10.2 If $\frac{\partial u}{\partial x} + \frac{\partial v}{\partial y} = 0$ for a turbulent flow then it signifies that

- (a) bulk momentum transfer is conserved
- (b) $u' v'$ is non-zero and positive
- (c) turbulence is anisotropic
- (d) none of the above

[ESE : 1996]

10.3 In a turbulent flow, \bar{u} , \bar{v} and \bar{w} are time average velocity components. The fluctuating components are u' , v' and respectively w' . The turbulence is said to be isotropic if

- (a) $\bar{u} = \bar{v} = \bar{w}$
- (b) $\bar{u} + u' = \bar{v} + v' = \bar{w} + w'$
- (c) $(\bar{u})^2 + (\bar{v})^2 = (\bar{w})^2$
- (d) None of the above situations prevails

[ESE : 1997]

10.4 Shear stress in a turbulent flow is due to

- (a) the viscous property of the fluid
- (b) the fluid density
- (c) fluctuation of velocity in the direction of flow
- (d) fluctuation of the velocity in the direction of flow as well as transverse to it

[ESE : 1997]

10.5 In a turbulent flow, L is the Prandtl's mixing length

and $\frac{\partial \bar{u}}{\partial y}$ is the gradient of the average velocity in the direction normal to flow. The final expression for the turbulent viscosity ν_t is given by

- (a) $\nu_t = L \left(\frac{\partial \bar{u}}{\partial y} \right)$
- (b) $\nu_t = \frac{1}{L^2} \left(\frac{\partial \bar{u}}{\partial y} \right)$
- (c) $\nu_t = L^2 \left(\frac{\partial \bar{u}}{\partial y} \right)$
- (d) $\nu_t = \frac{1}{L} \left(\frac{\partial \bar{u}}{\partial y} \right)$

[ESE : 1997]

10.6 In a fully turbulent flow through a rough pipe, the friction factor f is (Re is the Reynolds number and k/D is relative roughness)

- (a) a function of Re
- (b) a function of Re and k/D
- (c) a function of k/D
- (d) independent of Re and k/D

[ESE : 1998]



Answers Turbulent Flow

10.1 (b) 10.2 (b) 10.3 (b) 10.4 (d) 10.5 (c) 10.6 (c)

Explanations Turbulent Flow**10.1 (b)**

Frictional head loss in a turbulent flow through pipes are proportional to U^n (where, $1.7 < n < 2$)

10.3 (b)

Turbulence is said to be isotropic if

$$\bar{U} + u' = \bar{V} + v' = \bar{W} + w'$$

10.4 (d)

Due to continuous and quick fluctuations in velocity components in all the three directions, continuous mixing of liquid takes place in turbulent flow. This results in a lot of transfer of momentum which results in shear stresses in case of turbulent flow in addition to the viscous shear stresses. The total shear is the sum of viscous shear and the turbulent shear.

$$\tau = \mu \frac{d\bar{u}}{dy} + \eta \frac{d\bar{u}}{dy}$$

10.5 (c)

By Prandtl's mixing length theory

Shear stress

$$\tau = \rho l^2 \left(\frac{d\bar{u}}{dy} \right)^2$$

and $\tau = \eta \left(\frac{d\bar{u}}{dy} \right)$

$$\therefore \eta = \rho l^2 \left(\frac{d\bar{u}}{dy} \right)$$

$$v_t = \frac{\eta}{\rho} = l^2 \left(\frac{d\bar{u}}{dy} \right)$$

10.6 (c)

In case of turbulent flow, friction factor depends on Reynolds number and surface roughness.

$$\frac{1}{\sqrt{f}} = 2.0 \log_{10} \left(\frac{R_e}{k} \right) + 1.74$$

■■■■

11.1 List-I gives the different items related to a boundary layer while **List-II** gives the mathematical expression. Match **List-I** with **List-II** and select the correct answer using the codes given below the lists: (symbols have their usual meaning)

List-I

- A. Boundary layer thickness
 B. Displacement thickness
 C. Momentum thickness
 D. Energy thickness

List-II

1. $y = \delta, u = 0.99U_\infty$
 2. $\int_0^\delta \left(1 - \frac{u}{U_\infty}\right) dy$
 3. $\int_0^\delta \frac{u}{U_\infty} \left(1 - \frac{u}{U_\infty}\right) dy$
 4. $\int_0^\delta \frac{u}{U_\infty} \left(1 - \left(\frac{u}{U_\infty}\right)^2\right) dy$

Codes:

	A	B	C	D
(a)	1	2	3	4
(b)	2	1	4	3
(c)	2	1	3	4
(d)	1	2	4	3

[ESE : 1995]

11.2 A laminar boundary layer occurs over a flat plate at zero incidence of the flow. The thickness of boundary layer at a section 2 m from the leading edge is 2 mm. The thickness of boundary layer at a section 4 m from the leading edge in mm will be

- (a) $2 \times (2)^2$ (b) $2 \times (2)^{1/2}$
 (c) $2 \times (2)^{4/5}$ (d) $2 \times (2)^{1/5}$

[ESE : 1995]

11.3 In the region of the boundary layer nearest to the wall where velocity is not equal to zero, the viscous forces are

- (a) of the same order of magnitude as the inertial forces
 (b) more than inertial forces
 (c) less than inertial forces
 (d) negligible

[ESE : 1995]

11.4 In which one of the following cases separation of boundary layer must occur?

- (a) $\frac{dp}{dx} < 0$
 (b) $\frac{dp}{dx} = 0$
 (c) $\frac{dp}{dx} > 0$
 (d) $\frac{dp}{dx} > 0$ and the velocity profile has a point of inflection

[ESE : 1995]

11.5 At the point of boundary layer separation

- (a) shear stress is maximum
 (b) shear stress is zero
 (c) velocity is negative
 (d) density variation is maximum

[ESE : 1996]

11.6 The turbulent boundary layer thickness varies as

- (a) $x^{4/5}$ (b) $x^{1/5}$
 (c) $x^{1/2}$ (d) $x^{1/7}$

[ESE : 1996]

11.7 During the growth of turbulent boundary layer over a flat plate for a moderately high Reynolds number, the boundary layer thickness, δ varies as

- (a) $x^{1/3}$ (b) $x^{1/2}$
 (c) $x^{4/5}$ (d) $x^{7/8}$

[ESE : 1997]

11.8 Given that

δ = boundary layer thickness,

δ^* = displacement thickness,

δ_e = energy thickness and

θ = momentum thickness

The shape factor H of a boundary layer is given by

(a) $H = \frac{\delta_e}{\delta}$ (b) $H = \frac{\delta^*}{\theta}$

(c) $H = \frac{\delta}{\theta}$ (d) $H = \frac{\delta}{\delta^*}$

[ESE : 1997]

11.9 If U_∞ = free stream velocity, u = velocity at a distance y and δ = boundary layer thickness, then in a boundary layer flow, the momentum thickness θ is given by

(a) $\theta = \int_0^\delta \frac{u}{U_\infty} \left(1 - \frac{u}{U_\infty}\right) dy$

(b) $\theta = \int_0^\delta \frac{u}{U_\infty} \left(1 - \left(\frac{u}{U_\infty}\right)^2\right) dy$

(c) $\theta = \int_0^\delta \left(\frac{u}{U_\infty}\right)^2 \left(1 - \frac{u}{U_\infty}\right) dy$

(d) $\theta = \int_0^\delta \left(1 - \frac{u}{U_\infty}\right) dy$ [ESE : 1997]

11.10 Flow separation is caused by

- (a) reduction of pressure to local vapour pressure
- (b) a negative pressure gradient
- (c) a positive pressure gradient
- (d) thinning of boundary layer thickness to zero

[ESE : 1997]

11.11 In a boundary layer developed along the flow, the pressure decreases in the downstream direction. The boundary layer thickness would

- (a) tend to decrease
- (b) remain constant
- (c) increase rapidly
- (d) increase gradually

[ESE : 1998]

11.12 Boundary layer is defined as

- (a) a thin layer at the surface where gradients of both velocity and temperature are small
- (b) a thin layer at the surface where velocity and velocity gradients are large
- (c) a thick layer at the surface where velocity and temperature gradients are large

- (d) a thin layer at the surface where gradients of both velocity and temperature are large

[ESE : 1998]

11.13 For turbulent boundary layer flow, the thickness of laminar sublayer δ is given by

(a) $\frac{v}{u^*}$ (b) $5 \left(\frac{v}{u^*}\right)$

(c) $5.75 \log\left(\frac{v}{u^*}\right)$ (d) $2300 \left(\frac{v}{u^*}\right)$

[ESE : 1999]

11.14 The correct sequence in ascending order of the magnitude of the given parameters is

- (a) boundary layer thickness, momentum thickness, displacement thickness
- (b) displacement thickness, boundary layer thickness, momentum thickness
- (c) momentum thickness, displacement thickness, boundary layer thickness
- (d) momentum thickness, boundary layer thickness, displacement thickness

[ESE : 1999]

11.15 The hydrodynamic boundary layer thickness is defined as the distance from the surface where the

- (a) velocity equals the local external velocity
- (b) velocity equals the approach velocity
- (c) momentum equals 99% of the momentum of the free stream
- (d) velocity equals 99% of the local external velocity

[ESE : 1999]

11.16 A viscous fluid flows over a flat plate at zero angle of attack.

Assertion (A): The thickness of boundary layer is an ever increasing one as its distance from the leading edge of the plate increases.

Reason (R): In practice, 99 per cent of the depth of the boundary layer is attained within a short distance from the leading edge.

- (a) Both **A** and **R** are individually true and **R** is the correct explanation of **A**
- (b) Both **A** and **R** are individually true but **R** is not the correct explanation of **A**
- (c) **A** is true but **R** is false
- (d) **A** is false but **R** is true

[ESE : 1999]



Answers Boundary Layer Theory

11.1 (a) 11.2 (b) 11.3 (b) 11.4 (c) 11.5 (b) 11.6 (a) 11.7 (c) 11.8 (b) 11.9 (a)
11.10 (c) 11.11 (a) 11.12 (d) 11.13 (b) 11.14 (c) 11.15 (d) 11.16 (d)

Explanations Boundary Layer Theory**11.1 (a)**

Boundary layer thickness: It is defined as the distance from the boundary in which the velocity reaches 99% of the free stream velocity.

Displacement thickness: It is defined as the distance perpendicular to the boundary by which the boundary will have to be displaced outward so that the actual discharge would be same as that of an ideal fluid past the displaced boundary.

$$\delta^* = \int_0^{\delta} \left(1 - \frac{u}{U_{\infty}}\right) dy$$

Momentum thickness: It is defined as the distance measured perpendicular from the actual boundary such that the momentum flux through this distance equal to the deficit of momentum flux due to boundary layer formation.

$$\theta = \int_0^{\delta} \left(1 - \frac{u}{U_{\infty}}\right) \left(\frac{u}{U_{\infty}}\right) dy$$

Energy thickness: It is a distance perpendicular to the boundary by which the boundary have to be displaced to compensate for reduction in kinematic energy of fluid caused due to formation of boundary layer.

$$\delta_e = \int_0^{\delta} \left[1 - \left(\frac{u}{U_{\infty}}\right)^2\right] \frac{u}{U_{\infty}} dy$$

11.2 (b)

Thickness of laminar boundary (δ) $\propto x^{\frac{1}{2}}$

$$\therefore \frac{2}{\sqrt{2}} = \frac{\delta'}{\sqrt{4}}$$

$$\therefore \delta' = 2\sqrt{2} \text{ mm}$$

11.3 (b)

At nearest to the wall viscous forces are more than inertia forces.

11.5 (b)

At the verge of separation $\left(\frac{\partial u}{\partial y}\right)_{y=0}$ is zero

\therefore Shear stress: $\tau = \mu \left(\frac{\partial u}{\partial y}\right)_{y=0}$ is also zero

11.6 (a)

$$\frac{\delta}{x} = \frac{0.379}{(Re_x)^{1/5}} = \frac{0.379}{\left(\frac{U_0 x}{\nu}\right)^{1/5}}$$

$$\delta \propto x^{4/5}$$

11.7 (c)

In turbulent flow boundary layer thickness

$$\delta = \frac{0.377x}{(Re_x)^{1/5}} \Rightarrow \delta \propto \left(\frac{x^4}{u}\right)^{1/5}$$

11.8 (b)

Shape factor = $\frac{\text{Displacement thickness}}{\text{Momentum thickness}}$

11.9 (a)

Momentum thickness: It is defined as the distance measured perpendicular from the actual boundary such that the momentum flux through this distance is equal to the deficit of momentum flux due to boundary layer formation.

$$\theta = \int_0^{\infty} \left(1 - \frac{u}{U_{\infty}}\right) \left(\frac{u}{U_{\infty}}\right) dy$$

11.10 (c)

When the pressure goes increasing $\left(\frac{\partial p}{\partial x} > 0\right)$ in the direction of flow, the pressure force acts against the direction of direction of flow thus retarding the flow. This has an effect of retarding the flow in the boundary layer and hence thickening

the boundary layer more rapidly. This and the boundary shear bring the fluid in the boundary layer to rest and causes back flow. Due to this the boundary layer no more sticks to the boundary but is shifted away from the boundary. This phenomenon is called as "Boundary layer separation".

11.11 (a)

Boundary layer thickness decreases for favorable pressure gradient.

11.12 (d)

The boundary layer thickness (δ) is the distance across a boundary layer from the wall to a point where the flow velocity has essentially reached the free stream velocity. Thus velocity gradient will be large. It is thin shear layer.

Similarly thermal boundary layer exist in heat transfer. Multiple type of boundary layer can coexist near a surface simultaneously.

11.13 (b)

Nikuradse's experiment
Laminar sub layer,

$$\delta = \frac{5v}{\sqrt{\frac{\tau_0}{\rho}}} = \frac{5v}{u^*}$$

11.14 (c)

Momentum thickness < displacement thickness
< boundary layer thickness.

11.15 (d)

Boundary layer thickness:- It is defined as that distance from the boundary in which the velocity reaches 99% of the main stream velocity.

11.16 (d)

The thickness of boundary layer increases as its distance from leading edge of plate increases, but after some distance boundary layer breaks.



MADE EASY

12

Open Channel Flow (Not in Syllabus)

- 12.1** A hydraulic jump occurs in a channel
- whenever the flow is supercritical
 - if the flow is controlled by a sluice gate
 - if the bed slope changes from mild to steep
 - if the bed slope changes from steep to mild
- [ESE : 1997]

- 12.2** Consider the following statements regarding a hydraulic jump:
- There occurs a transformation of supercritical flow to subcritical flow.
 - The flow is uniform and pressure distribution is due to hydrostatic force before and after the jump.
 - There occurs loss of energy due to eddy formation and turbulence.

Which of these statements are correct?

- 1, 2 and 3
- 1 and 2
- 2 and 3
- 1 and 3

[ESE : 1999]

- 12.3 Assertion (A):** To have maximum hydraulic efficiency, the trapezoidal section of an open channel should be a half-hexagon.

Reason (R): For any cross-section, a hexagon has the least perimeter.

- Both **A** and **R** are individually true and **R** is the correct explanation of **A**
- Both **A** and **R** are individually true but **R** is not the correct explanation of **A**
- A** is true but **R** is false
- A** is false but **R** is true

[ESE : 1999]

■ ■ ■ ■

Answers Open Channel Flow

12.1 (a) 12.2 (a) 12.3 (a)

Explanations Open Channel Flow

12.1 (a)

The hydraulic jump is defined as the sudden and turbulent passage of water from a supercritical state.

12.2 (a)

Assumptions for hydraulic jump.

- It is assumed that before and after jump formation the flow is uniform and the pressure distribution is hydrostatic.
- The length of the jump is small so that the losses due to friction on the channel floor are small and hence neglected.
- The channel flow is horizontal or the slope is so gentle that the weight component of the water mass comprising the jump is negligibly small.

12.3 (a)

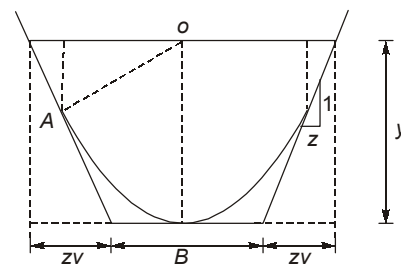

Most economical or most efficient trapezoidal channel section: For a trapezoidal channel section of bottom width B , depth of flow y and side slope z horizontal to 1 vertical (as shown in figure), following expression for wetted area A and wetted perimeter P can be written

$$A = (B + Zy) y \quad \dots (i)$$

$$P = B + 2y(1 + z^2) \quad \dots (ii)$$

from equation (i)

$$B = \frac{A}{y} - zy$$

Substituting the value of B in equation (ii) it becomes

$$P = \frac{A}{y} - zy + 2y\sqrt{1+z^2} \quad \dots(iii)$$

Assuming area A and side slope z to be constant equation (iii) can be differentiated with respect to y and equated to zero for obtaining the condition for

Minimum P.

$$\text{Thus } \frac{dP}{dy} = -\frac{A}{y^2} - z + 2\sqrt{1+z^2} = 0$$

$$\frac{A}{y^2} + z = 2\sqrt{1+z^2}$$

Substituting the value of A from equation (i) the above equation becomes

$$\frac{(B+zy)y}{y^2} + z = 2\sqrt{1+z^2}$$

$$\therefore B = 2y(\sqrt{1+z^2} - z) \quad \dots(iv)$$

Equation (iv) is the required condition for a trapezoidal channel section to be most economical or most efficient. It shows that for a trapezoidal channel section to be most economical or most efficient, half the top width must be equal to one of the sloping sides of the channel i.e. hexagon.



MADE EASY

13.1 For solid spheres falling vertically downwards under gravity in viscous fluid, the terminal velocity, V varies with diameter D of the sphere as

- (a) $V \propto D^{1/2}$ for all diameters
- (b) $V \propto D^2$ for all diameters
- (c) $V \propto D^{1/2}$ for large D and $V \propto D^2$ for small D
- (d) $V \propto D^2$ for large D and $V \propto D^{1/2}$ for small D

[ESE : 1995]

13.2 Flow over a half body is studied by utilizing a free stream velocity of 5 m/s superimposed on a source at the origin. The body has a maximum width of 2 m. The co-ordinates of the stagnation point are

- (a) $x = 0.32$ m, $y = 0$
- (b) $x = 0$, $y = 0$
- (c) $x = -0.32$ m, $y = 0$
- (d) $x = 3$ m, $y = 2$ m

[ESE : 1995]

13.3 During the flow over a circular cylinder, the drag coefficient drops significantly at a critical Reynolds number of 2×10^5 . This is due to

- (a) excessive momentum loss in the boundary layer
- (b) separation point travelling upstream
- (c) reduction in skin-friction drag
- (d) the delay in separation due to transition to turbulence

[ESE : 1996]

13.4 Telephone wires often snap due to crossflow of wind past the wires. The main reason for this is

- (a) the force exerted by the wind on the wires is large in magnitude
- (b) poor quality of the work executed
- (c) wide variation of wind velocity in magnitude
- (d) vortex shedding

[ESE : 1997]

13.5 Which one of the following statements is true of flow around a submerged body?

- (a) For subsonic, non-viscous flow, the drag is zero.
- (b) For supersonic flow, the drag coefficient is dependent equally on Mach number and Reynolds number.
- (c) The lift and drag coefficients of an aerofoil is independent of Reynolds number.
- (d) For incompressible flow around an aerofoil, the profile drag is the sum of form drag and skin friction drag.

[ESE : 1998]

13.6 Consider the following statements:

1. The cause of stalling of an aerofoil is the boundary layer separation and formation of increased zone of wake.
2. An aerofoil should have a rounded nose in supersonic flow to prevent formation of new shock.
3. When an aerofoil operates at an angle of incidence greater than that of stalling, the lift decreases and drag increases.
4. A rough ball when at certain speeds can attain longer range due to reduction of lift as the roughness induces early separation.

Which of these statements are correct?

- (a) 3 and 4
- (b) 1 and 2
- (c) 2 and 4
- (d) 1 and 3

[ESE : 1999]

13.7 A parachutist has a mass of 90 kg and a projected frontal area of 0.30 m^2 in free fall. The drag coefficient based on frontal area is found to be 0.75. If the air density is 1.28 kg/m^3 , the terminal velocity of the parachutist will be

- (a) 104.4 m/s
- (b) 78.3 m/s
- (c) 25 m/s
- (d) 18.5 m/s

[ESE : 1999]



Answers Drag and Lift

13.1 (b) 13.2 (c) 13.3 (d) 13.4 (d) 13.5 (d) 13.6 (d) 13.7 (b)

Explanations Drag and Lift

13.1 (b)

Stokes' formula forms the basis for determination of viscosity of oils which consists of allowing a sphere of known diameter to fall freely in the oil. After initial acceleration. The sphere attains a constant velocity known as Terminal Velocity Which is reached when the external drag on the surface and buoyancy, both acting upwards and in opposite to the motions, become equal to the downward force due to gravity.

$$6\mu U_t R + \frac{4}{3}\pi R^3 \rho g = \frac{4}{3}\pi R^3 \rho_t g$$

(drag) + (Buoyancy) = (Gravity)

ρ = density of fluid

ρ_t = density of the sphere material

U_t = terminal velocity

$$6\mu U_t = \frac{4}{3}R^2 (\rho_t - \rho)g$$

$$U_t = \frac{2R^2}{9\mu} (\rho_t - \rho)g$$

$$= \frac{D^2}{18\mu} (\rho_t - \rho)g$$

13.2 (c)

A is the stagnation point and O is the origin.

$$-x = \frac{q}{2\pi v} = \frac{2 \times 5}{2\pi \times 5} = 0.32 \text{ m}$$

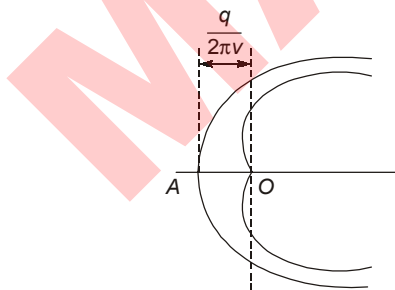

$$x = -0.32 \text{ m}$$

$$y = 0$$

13.3 (d)

The drag coefficient remains practically constant until a Reynold's number of 2×10^5 is reached. At this stage the C_d drops steeply by a factor of 5. This is due to the fact that the laminar boundary layer turns turbulent and stays unseparated over a longer distance, then reducing the wake considerably.

13.4 (d)

The 'singing' of telephone or transmission line wire in high winds is caused when the frequency of vortex shedding is close to the natural frequency of the wire.

13.5 (d)

- (i) for subsonic and supersonic flow drag force is dependent on Mach number.
- (ii) The coefficient of drag in the case of an aerofoil will necessarily depends on Re and its shape.

13.7 (b)

$$\text{Weight of parachutist} = C_d \times \frac{1}{2} \rho v^2 A$$

$$90 \times 9.81 = 0.75 \times \frac{1}{2} \times 1.28 \times v^2 \times 0.3$$

$$\therefore v = \sqrt{\frac{90 \times 9.81 \times 2}{0.75 \times 0.3 \times 1.28}}$$

$$= \sqrt{6131.25} = 78.3 \text{ m/s}$$



14.1 A dimensionless group formed with the variables ρ (density), ω (angular velocity), μ (dynamic viscosity) and D (characteristic diameter) is

- (a) $\frac{\rho\omega\mu}{D^2}$ (b) $\frac{\rho\omega D^2}{\mu}$
 (c) $\rho\omega\mu D^2$ (d) $\rho\omega\mu D$ [ESE : 1995]

14.2 The model of a propeller, 3 m in diameter, cruising at 10 m/s in air, is tested in a wind tunnel on a 1 : 10 scale model. If a thrust of 50 N is measured on the model at 5 m/s wind speed, then the thrust on the prototype will be

- (a) 20,000 N (b) 2,000 N
 (c) 500 N (d) 200 N [ESE : 1995]

14.3 Match List-I (Predominant force) with List-II (Dimensionless numbers) and select the correct answer using the codes given below the lists:

List-I

- A. Compressibility force
 B. Gravity force
 C. Surface tension force
 D. Viscous force

List-II

1. Euler number
 2. Froude number
 3. Mach number
 4. Reynolds numbers
 5. Weber number

Codes:

	A	B	C	D
(a)	1	2	3	4
(b)	3	2	5	4
(c)	3	1	4	2
(d)	2	3	5	1

[ESE : 1996]

14.4 Kinematic similarity between model and prototype is the similarity of

- (a) shape (b) discharge
 (c) stream (d) forces

[ESE : 1996]

14.5 The variables controlling the motion of a floating vessel through water are the drag force F , the speed v , the length L , the density ρ , dynamic viscosity μ of water and gravitational constant g . If the non-dimensional groups are Reynolds number (Re), Weber number (We), Prandtl number (Pr) and Froude number (Fr), the expression for F is given by

- (a) $\frac{F}{\rho v^2 L^2} = f(Re)$
 (b) $\frac{F}{\rho v^2 L^2} = f(Re, Pr)$
 (c) $\frac{F}{\rho v^2 L^2} = f(Re, We)$
 (d) $\frac{F}{\rho v^2 L^2} = f(Re, Fr)$ [ESE : 1997]

14.6 Euler number is defined as the ratio of inertia force to

- (a) viscous force (b) elastic force
 (c) pressure force (d) gravity force

[ESE : 1997]

14.7 If ' n ' variables in a physical phenomenon contained ' m ' fundamental dimensions, then the variable can be arranged into

- (a) n dimensionless terms
 (b) m dimensionless term
 (c) $(n - m)$ dimensionless terms
 (d) $(n + m)$ dimensionless terms

[ESE : 1998]

14.8 A 1 : 20 model of a spillway dissipated 0.25 hp. The corresponding prototype horsepower dissipated will, be

- (a) 0.25 hp (b) 5.00 hp
 (c) 447.20 hp (d) 8944.30 hp

[ESE : 1998]

- 14.9** A 1 : 256 scale model of a reservoir is drained in 4 minutes by opening the sluice gate. The time required to empty the prototype will be
 (a) 128 minutes
 (b) 64 minutes
 (c) 32 minutes
 (d) 25.4 minutes

[ESE : 1999]

- 14.10** A sphere is moving in water with a velocity of 1.6 m/s. Another sphere of twice the diameter is placed in a wind tunnel and tested with air which is 750 times less dense and 60 times less viscous than water. The velocity of air that will give dynamically similar conditions is
 (a) 5 m/s (b) 10 m/s
 (c) 20 m/s (d) 40 m/s

[ESE : 1999]

- 14.11** If the number of fundamental dimensions equals 'm', then the repeating variables shall be equal to
 (a) m and none of the repeating variables shall represent the dependent variable
 (b) m + 1 and one of the repeating variables shall represent the dependent variable
 (c) m + 1 and none of the repeating variables shall represent the dependent variable
 (d) m and one of the repeating variables shall represent the dependent variable

[ESE : 1999]

- 14.12** A ship model 1/60 scale with negligible friction is tested in a towing tank at a speed of 0.6 m/s. If a force of 0.5 kg is required to tow the model, the propulsive force required to tow prototype ship will be
 (a) 5 MN (b) 3 MN
 (c) 1 MN (d) 0.5 MN

[ESE : 1999]



Answers Dimensional Analysis

- 14.1** (b) **14.2** (a) **14.3** (b) **14.4** (b) **14.5** (d) **14.6** (c) **14.7** (c) **14.8** (d) **14.9** (b)
14.10 (b) **14.11** (a) **14.12** (c)

Explanations Dimensional Analysis

14.1 (b)

Let $\pi = \rho^a D^b \mu^c \omega$
 $M^0 L^0 T^0 = [ML^{-3}]^a [L]^b [ML^{-1}T^{-1}]^c [T^{-1}]$
 $a + c = 0 \dots (i)$
 $-3a + b - c = 0 \dots (ii)$
 $-c - 1 = 0 \dots (iii)$
 Hence $a = 1, b = 2, \text{ and } c = -1$

$\therefore \pi = \frac{\rho \omega D^2}{\mu}$

Alternate solution: Check the dimensions individually.

$$\frac{50}{F_p} = \left(\frac{5}{10}\right)^2 \left(\frac{1}{10}\right)^2$$

$$F_p = 20,000 \text{ N}$$

14.2 (a)

$$\frac{\text{Thrust of model}}{\text{Thrust of prototype}} = \frac{(\rho v^2 d^2)_{\text{model}}}{(\rho v^2 d^2)_{\text{prototype}}}$$

14.3 (b)

- Euler number = $\frac{\text{Inertia force}}{\text{Pressure force}}$
 Froude number = $\frac{\text{Inertia force}}{\text{Gravity force}}$
 Weber number = $\frac{\text{Inertia force}}{\text{Surface tension force}}$
 Reynolds number = $\frac{\text{Inertia force}}{\text{Viscous force}}$

14.4 (b)

Kinematic similarity: If the ratio of velocity and acceleration at the corresponding points in the model and prototype are same then there exist kinematic similarity.

14.5 (d)

Drag force, $F = \phi(V, \rho, U, L, g)$

$$\frac{F}{\rho L^2 V^2} = Q\left(\frac{\rho V L}{\mu}, \frac{V}{\sqrt{g L}}\right) = \phi(Re, Fr)$$

14.6 (c)

Euler number:

$$E = \left(\frac{\text{Inertia force}}{\text{Pressure force}}\right)^{1/2} = \frac{V}{\sqrt{\rho/\rho}}$$

Weber number:

$$W = \left(\frac{\text{Inertia force}}{\text{Surface tension}}\right)^{1/2} = \frac{V}{\sqrt{\sigma/\rho L}}$$

Mach number:

$$M = \left(\frac{\text{Inertia force}}{\text{Elastic force}}\right) = \frac{V}{\sqrt{K/\rho}}$$

14.7 (c)

Buckingham's π theorem: It states that if there are ' n ' variable involved contain physical phenomenon and if these variable contain ' m ' primary dimensions (e.g. M, L, T) then the variable quantities can be expressed in terms of an equation containing $(n - m)$ dimensionless groups or parameters.

14.8 (d)

$$\begin{aligned} v &\propto \sqrt{L} \\ &= \frac{1}{2} \rho v^3 D^2 = \frac{1}{2} \rho (\sqrt{20})^3 (20)^2 \\ &= 8944.3 \text{ hp} \end{aligned}$$

14.9 (b)

$$\begin{aligned} t &\propto \sqrt{h} \\ \therefore t_p &= \sqrt{256} \times t_m \\ &= 16 \times 4 = \mathbf{64 \text{ min}} \end{aligned}$$

14.10 (b)

For dynamically similar condition

$$Re_1 = Re_2$$

$$\frac{\rho_1 V_1 D_1}{\mu_1} = \frac{\rho_2 V_2 D_2}{\mu_2}$$

$$\frac{750 \rho_2 \times 1.6 \times D_1}{60 \mu_2} = \frac{\rho_2 V_2 2 D_1}{\mu_2}$$

$$\therefore V_2 = \frac{750 \times 1.6}{60 \times 2} = \mathbf{10 \text{ m/s}}$$

14.11 (a)

Rules for selecting repeated variable.

1. Number of repeated variables is equal to number of fundamental quantities.
2. Repeated variable must be selected from independent variables.

14.12 (c)

For dynamic similarity, as per Froude law

$$\left(\frac{V}{\sqrt{gL}}\right)_m = \left(\frac{V}{\sqrt{gL}}\right)_P$$

$$\frac{V_m}{V_P} = \sqrt{\frac{L_m}{L_P}} = \sqrt{60}$$

Propulsive force of prototype

$$F_P = F_m \left(\frac{V_m}{V_P}\right)^2 \times \left(\frac{L_m}{L_P}\right)^2$$

$$= F_m \left[\left(\sqrt{\frac{L_m}{L_P}}\right)^2 \left(\frac{L_m}{L_P}\right)^2 \right]$$

$$= 0.5 \times 10 \times (60)^3 = 1080000 \text{ N} \approx \mathbf{1 \text{ MN}}$$

■■■■

UNIT



Thermodynamics

Syllabus

Thermodynamic systems and processes; properties of pure substance; Zeroth, First and Second Laws of Thermodynamics; Entropy, Irreversibility and availability; analysis of thermodynamic cycles related to energy conversion, ideal and real gases; compressibility factor; Gas mixtures.

Contents

Sl.	Topic	Page No.
1.	Thermodynamic System, Processes and Zeroth Law	42
2.	First Law, Heat and Work, Energy	44
3.	Second Law, Carnot Cycle and Entropy	49
4.	Irreversibility and Availability	54
5.	Thermodynamic Relations	55
6.	Pure Substances	57



1

Thermodynamic System, Processes and Zeroth Law

- 1.1 The correct sequence of the decreasing order of the value of characteristic gas constants of the given gases is
- (a) hydrogen, nitrogen, air, carbon dioxide
 - (b) carbon dioxide, hydrogen, nitrogen, air
 - (c) air, nitrogen, carbon dioxide, hydrogen
 - (d) nitrogen, air, hydrogen, carbon dioxide
- [ESE : 1995]
- 1.2 **Assertion (A):** If an alcohol and a mercury thermometer read exactly 0°C at the ice point and 100°C at the steam point and the distance between the two points is divided into 100 equal parts in both thermometers, the two thermometers will give exactly the same reading at 50°C .
- Reason (R):** Temperature scales are arbitrary.
- (a) both **A** and **R** are true and **R** is the correct explanation of **A**
 - (b) both **A** and **R** are true but **R** is not a correct explanation of **A**
 - (c) **A** is true but **R** is false
 - (d) **A** is false but **R** is true
- [ESE : 1995]
- 1.3 Zeroth Law of thermodynamics states that
- (a) two thermodynamic systems are always in thermal equilibrium with each other
 - (b) if two systems are in thermal equilibrium, then the third system will also be in thermal equilibrium
 - (c) two systems not in thermal equilibrium with a third system will also not be in thermal equilibrium with each other
 - (d) when two systems are in thermal equilibrium with a third system, they are in thermal equilibrium with each other
- [ESE : 1996]
- 1.4 Two blocks which are at different states are brought into contact with each other and allowed to reach a final state of thermal equilibrium. The final temperature attained is specified by the
- (a) Zeroth law of thermodynamics
 - (b) First law of thermodynamics
 - (c) Second law of thermodynamics
 - (d) Third law of thermodynamics
- [ESE : 1998]
- 1.5 A closed thermodynamic system is one in which
- (a) there is no energy or mass transfer across the boundary
 - (b) there is no mass transfer, but energy transfer exists
 - (c) there is no energy transfer, but mass transfer exists
 - (d) both energy and mass transfer take place across the boundary, but the mass transfer is controlled by valves
- [ESE : 1999]
- 1.6 Which one of the following is the extensive property of a thermodynamic system?
- (a) Volume
 - (b) Pressure
 - (c) Temperature
 - (d) Density
- [ESE : 1999]
-

Answers Thermodynamic System, Processes and Zeroth Law

- 1.1 (a) 1.2 (d) 1.3 (d) 1.4 (b) 1.5 (b) 1.6 (a)

Explanations Thermodynamic System, Processes and Zeroth Law**1.1 (a)**

Characteristic gas constant,

$$R = \frac{\text{Universal gas constant}(\bar{R})}{\text{Molecular weight}(M)}$$

$$\text{Hence, } R \propto \frac{1}{M}$$

Molecular weight of gases are

Hydrogen : 2

Nitrogen : 28

Air : 29

Carbon dioxide : 44

$$\text{Hence } R_{H_2} > R_{N_2} > R_{Air} > R_{CO_2}$$

1.2 (d)

The expansion of different fluid does not vary linearly with temperature.

1.3 (d)

Zeroth law of thermodynamics states that when a body *A* is in thermal equilibrium with a body *B*, and also separately with a body *C*, then *B* and *C* will be in thermal equilibrium with each other. This is the basis of temperature measurement.

1.4 (b)

Final temperature is being calculated by applying conservation of energy i.e. First law of thermodynamics.

1.5 (b)

A closed system consists of fixed amount of mass and no mass can cross its boundary but energy in the form of heat and work can cross the boundary.

1.6 (a)

Properties are either intensive or extensive. Intensive properties are those that are independent of the mass of a system such as temperature, pressure and density. Extensive properties are those whose values depend on the mass of system such as mass, volume etc.

■■■■

2

First Law, Heat and Work, Energy

- 2.1 The internal energy of certain system is a function of temperature alone and is given by the formula $E = 25 + 0.25t$ kJ. If this system executes a process for which the work done by it per degree temperature increase is 0.75 kNm, the heat interaction per degree temperature increase, in kJ, is
- (a) - 1.00 (b) - 0.50
(c) 0.50 (d) 1.00

[ESE : 1995]

- 2.2 The heat transfer Q , the work done W and the change in internal energy U are all zero in the case of
- (a) a rigid vessel containing steam at 150°C left in the atmosphere which is at 25°C
(b) 1 kg of gas contained in an insulated cylinder expanding as the piston moves slowly outwards
(c) a rigid vessel containing ammonia gas connected through a valve to an evacuated rigid vessel, the vessel, the valve and the connecting pipes being well insulated and the valve being opened and after a time, condition through the two vessel becoming uniform
(d) 1 kg of air flowing adiabatically from the atmosphere into a previously evacuated bottle

[ESE : 1996]

- 2.3 **Assertion (A):** Ratio of specific heats c_p/c_v decreases with increases in temperature.
Reason (R): With increase in temperature, c_p decreases at a higher rate than c_v .
- (a) both **A** and **R** are true and **R** is the correct explanation of **A**
(b) both **A** and **R** are true but **R** is not a correct explanation of **A**
(c) **A** is true but **R** is false
(d) **A** is false but **R** is true

[ESE : 1996]

- 2.4 Match the curves in **Diagram-I** (Process on p - V plane) with the curves in **Diagram-II** (Process on T - s plane) and select the correct answer:

Diagram-I

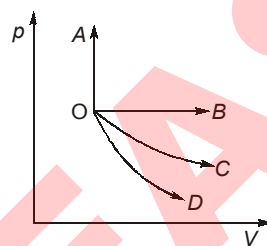
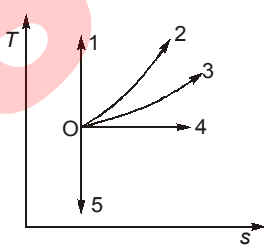

Diagram-II



Codes:

	A	B	C	D
(a)	3	2	4	5
(b)	2	3	4	5
(c)	2	3	4	1
(d)	1	4	2	3

[ESE : 1996]

- 2.5 Match **List-I** with **List-II** and select the correct answer using the codes given below the lists:

List-I

- A. Work done in a polytropic process
B. Work done in steady flow process
C. Heat transfer in a reversible adiabatic process
D. Work done in an isentropic process

List-II

1. $-\int V dp$
2. Zero
3. $\frac{p_1 V_1 - p_2 V_2}{\gamma - 1}$
4. $\frac{p_1 V_1 - p_2 V_2}{n - 1}$

Codes:

	A	B	C	D
(a)	4	1	3	2
(b)	1	4	2	3
(c)	4	1	2	3
(d)	1	2	3	4

[ESE : 1996]

2.6 When a system is taken from state A to state B along the path A-C-B, 180 kJ of the heat flows into the system and it does 130 kJ of work (as shown in the figure below):

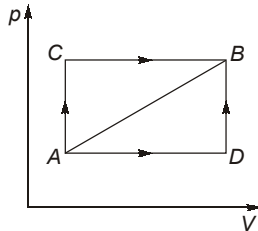

How much heat will flow into the system along the path A-D-B if the work done by it along the path is 40 kJ?

- (a) 40 kJ
- (b) 60 kJ
- (c) 90 kJ
- (d) 135 kJ

[ESE : 1997]

2.7 A gas expands from pressure p_1 to pressure p_2 ($p_2 = \frac{p_1}{10}$). If the process of expansion is isothermal, the volume at the end of expansion is 0.55 m^3 . If the process of expansion is adiabatic, the volume at the end of expansion will be closer to

- (a) 0.45 m^3
- (b) 0.55 m^3
- (c) 0.65 m^3
- (d) 0.75 m^3

[ESE : 1997]

2.8 The work done in compressing a gas isothermally is given by:

(a) $\frac{\gamma}{\gamma-1} p_1 V_1 \left[\left(\frac{p_2}{p_1} \right)^{\frac{\gamma-1}{\gamma}} - 1 \right]$

(b) $mRT_1 \ln \frac{p_2}{p_1}$

(c) $mc_p (T_2 - T_1)$

(d) $mRT_1 \left(1 - \frac{T_2}{T_1} \right)$

[ESE : 1997]

2.9 A control mass undergoes a process from state 1 to state 2 as shown in the figure below. During this process, the heat transfer to the system is 200 kJ. If the control mass returned adiabatically from state 2 to state 1 by another process, then the work interaction during the return process (in kN-m) would be

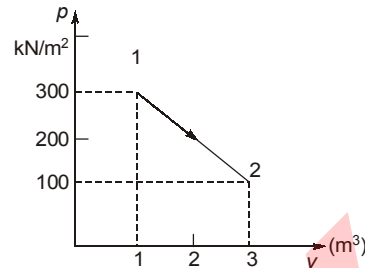

- (a) -400
- (b) -200
- (c) 200
- (d) 400

[ESE : 1998]

2.10 An ideal cycle is shown in the figure below. Its thermal efficiency is given by

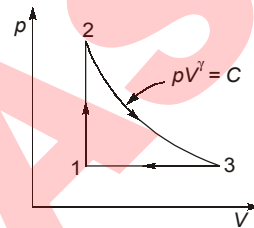

- (a) $\frac{\left(\frac{V_3 - 1}{V_1} \right)}{\left(\frac{p_2 - 1}{p_1} \right)}$
- (b) $1 - \frac{1}{\gamma} \left(\frac{V_3 - 1}{V_1} \right) \left(\frac{p_2 - 1}{p_1} \right)$
- (c) $1 - \gamma \frac{(V_3 - V_1) p_1}{(p_2 - p_1) V_1}$
- (d) $1 - \frac{1}{\gamma} \frac{(p_2 - p_1) V_1}{(V_3 - V_1) p_1}$

[ESE : 1998]

2.11 A tank containing air is stirred by a paddle wheel. The work input to the paddle wheel is 9000 kJ and the heat transferred to the surrounding from the tank is 3000 kJ. The external work done by the system is

- (a) Zero
- (b) 3000 kJ
- (c) 6000 kJ
- (d) 9000 kJ

[ESE : 1999]

2.12 The diagram shown in the figure represents reversible compression of air on the p-V coordinates. The work of compression needed a centrifugal compressor is equal to the area

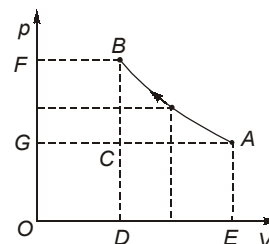

- (a) ABDE-ABC (b) ABDE
(c) ABFG (d) ABFG-ABC

[ESE : 1999]

Direction: Each of the next questions consists of two statements, one labelled as the 'Assertion (A)' and the other as 'Reason (R)'. You are to examine these two statements carefully and select the answers to these items using the codes given below:

Codes:

- (a) Both **A** and **R** are individually true and **R** is the correct explanation of **A**
(b) Both **A** and **R** are individually true but **R** is not the correct explanation of **A**
(c) **A** is true but **R** is false
(d) **A** is false but **R** is true

2.13 Assertion (A): The change in heat and work cannot be expressed as difference between the end states.

Reason (R): Heat and work both are exact differentials. [ESE : 1999]

2.14 Assertion (A): Heat can not spontaneously pass from a colder system to a hotter system without simultaneously producing other effects in the surroundings.

Reason (R): External work must be put into heat pump so that heat can be transferred from a cold to a hot body. [ESE : 1999]

2.15 Match List-I (Process) with List-II (Index n in $pV^n = C$) and select the correct answer using the codes given below the lists:

List-I	List-II
A. Adiabatic	1. $n = \text{Infinity}$
B. Isothermal	2. $n = c_p/c_v$
C. Constant pressure	3. $n = 1$
D. Constant volume	4. $n = c_p/c_v - 1$
	5. $n = \text{zero}$

Codes:

	A	B	C	D
(a)	2	3	5	4
(b)	2	3	5	1
(c)	3	2	1	5
(d)	2	5	3	1

[ESE : 1999]

■ ■ ■ ■

Answers First Law, Heat and Work, Energy

- 2.1 (d) 2.2 (c) 2.3 (c) 2.4 (b) 2.5 (c) 2.6 (c) 2.7 (a) 2.8 (b) 2.9 (b)
2.10 (c) 2.11 (a) 2.12 (c) 2.13 (c) 2.14 (b) 2.15 (b)

Explanations First Law, Heat and Work, Energy**2.1 (d)**

$$E = 25 + 0.25t$$

$$\frac{dE}{dt} = 0.25 \text{ kJ/}^\circ\text{C}$$

and $\frac{dW}{dt} = 0.75 \text{ kJ/}^\circ\text{C}$

From the first law of thermodynamics

$$\delta Q = dE + \delta W$$

$$\delta Q = 0.25 + 0.75 = 1.00 \text{ kJ/}^\circ\text{C}$$

2.2 (c)

This is the case of free expansion.

For free expansion

$$\delta Q = 0 \text{ and } \delta W = 0$$

First law for a process

$$\delta Q = dU + \delta W$$

$$0 = dU + 0$$

$$\therefore dU = 0$$

Hence for free expansion,
 $\delta Q = 0$, $\delta W = 0$ and $dU = 0$

2.3 (c)

With increase in temperature both c_p and c_v increase but the rate of increase of c_p is less than rate of increase of c_v thus c_p/c_v decreases.

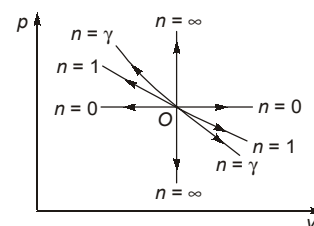
2.4 (b)

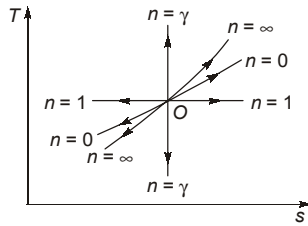

2.5 (c)

A. Work done in a polytropic process:

$$\frac{p_1 V_1 - p_2 V_2}{n - 1}$$

B. Work done in steady flow process:

$$-\int V dp$$

C. Heat transfer in a reversible adiabatic process:
Zero

D. Work done in an isentropic process:

$$\frac{p_1 V_1 - p_2 V_2}{\gamma - 1}$$

2.6 (c)

From First law of thermodynamics:

$$U_A + Q = U_B + W$$

$$U_B - U_A = Q - W = 180 - 130 = 50 \text{ kJ}$$

Since internal energy is property (is independent of path function.)

$$U_B - U_A = Q - W$$

$$50 = Q - 40$$

$$\Rightarrow Q = 90 \text{ kJ}$$

2.7 (a)

$$pV^n = C$$

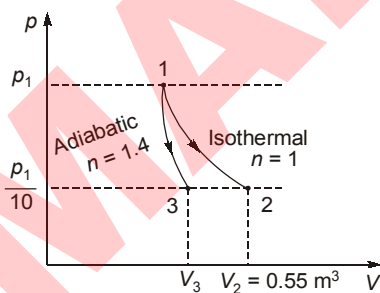

From the above figure

$$V_3 < V_2$$

Hence, $V_3 < 0.55 \text{ m}^3$

2.9 (b)

Intercept of path on X-axis is the work done by the process (in case of closed system)

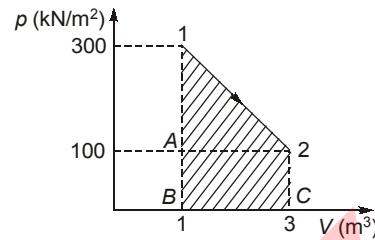

$W = \text{area under 1-2}$

$$W = \frac{1}{2} \times (3 - 1) \times 200 + 100 \times (3 - 1) = 200 + 200 = 400 \text{ kJ}$$

For process 1-2:

$$U_1 + Q = U_2 + W.$$

$$U_1 - U_2 = W - Q = 400 - 200 = 200 \text{ kJ.}$$

For process 2-1:

Since adiabatic

$$\text{So } Q = 0$$

$$U_2 + Q = U_1 + W$$

$$W = U_2 - U_1 = -(U_1 - U_2) = -200 \text{ kJ}$$

2.10 (c)

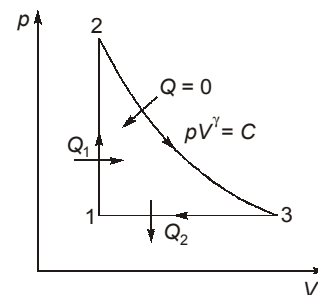

$$\text{Thermal efficiency: } \eta = \frac{Q_1 - Q_2}{Q_1}$$

$$1 - \frac{Q_2}{Q_1} = 1 - \frac{c_p(T_3 - T_1)}{c_v(T_2 - T_1)}$$

$$\text{Using } pV = nRT \text{ \& } \frac{c_p}{c_v} = \gamma$$

$$\therefore \eta = 1 - \gamma \frac{(V_3 - V_1) p_1}{(p_2 - p_1) V_1}$$

2.11 (a)

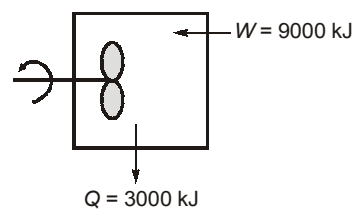

This is a case of constant volume process or an isochoric process. By performing work on the system temperature can be raised. In an irreversible constant volume process, the system doesn't perform work on the surrounding at the expense of its internal energy.

2.13(c)

The heat and work interaction depends upon the path followed by the process so assertion is correct only point function are exact differential, heat and work are path function hence they are inexact differential.

2.15(b)

Adiabatic process,

$$pV^\gamma = C, \text{ where } \gamma = \frac{C_p}{C_v}$$

Isothermal,

$$pV = C, \text{ value of } n = 1$$

Constant pressure,

$$p = C, \text{ value of } n = 0$$

Constant volume,

$$V = C, \text{ value of } n = \infty$$

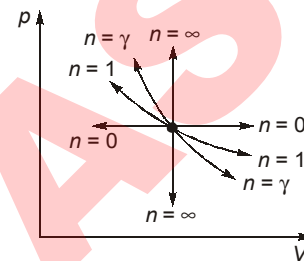

■■■■

3

Second Law, Carnot Cycle and Entropy

3.1 A cycle of pressure-volume diagram is shown in the given figure

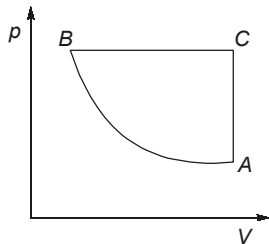

Same cycle on temperature-entropy diagram will be represented by

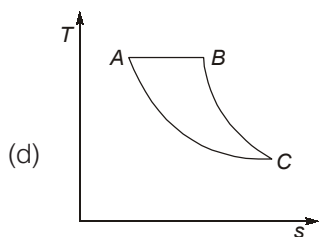
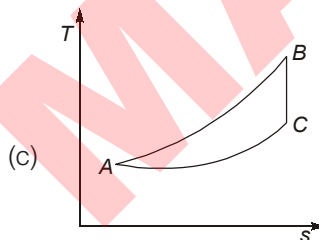
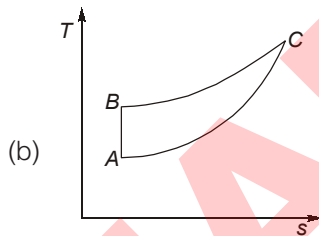
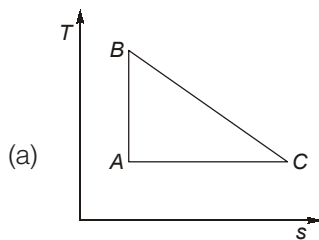

[ESE : 1995]

3.2 Which one of the following statements applicable to a perfect gas will also be true for an irreversible process? (Symbols have the usual meanings)

- (a) $dQ = dU + pdV$ (b) $dQ = TdS$
 (c) $Tds = dU + pdV$ (d) None of these

[ESE : 1996]

3.3 The throttling process undergone by a gas across an orifice is shown by its states in the following figure:

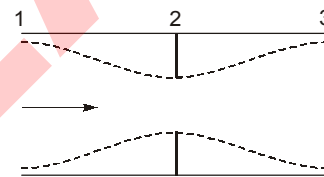

It can be represented on the diagram as

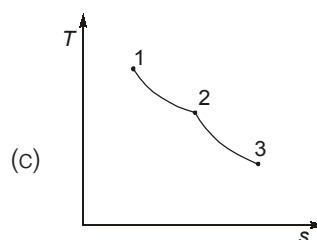
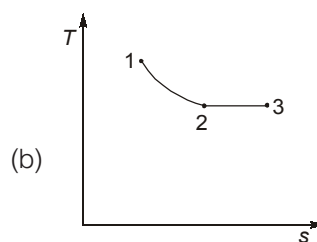
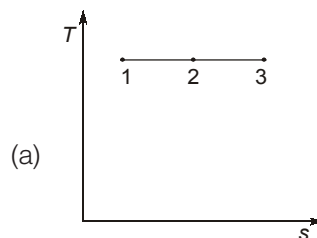

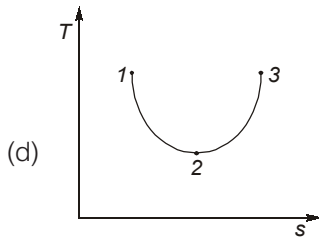

[ESE : 1996]

3.4 Which one on the following temperature entropy diagrams of steam shows the reversible and irreversible processes correctly?

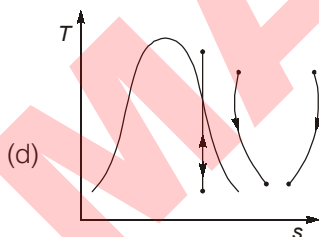
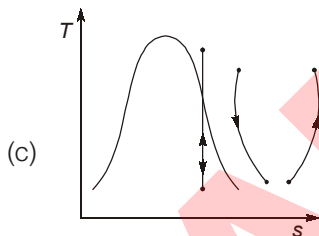
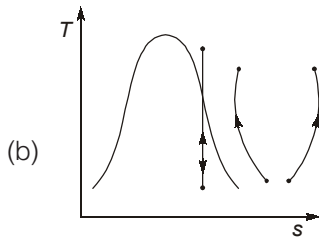
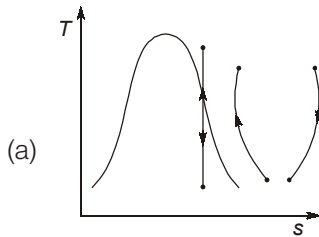

[ESE : 1996]

3.5 When a system undergoes a process such that

$$\int \frac{dQ}{T} = 0 \text{ and } \Delta S > 0, \text{ the process is}$$

- (a) irreversible adiabatic
- (b) reversible adiabatic
- (c) isothermal
- (d) isobaric

[ESE : 1997]

3.6 Consider the following statements:
When a perfect gas enclosed in a cylinder piston device executes a reversible adiabatic expansion process

- 1. Its entropy will increase.
- 2. its entropy change will be zero.
- 3. the entropy change of the surroundings will be zero.

Which of these statements is/are correct?

- (a) 1 and 3
- (b) 2 only
- (c) 2 and 3
- (d) 1 only

[ESE : 1997]

3.7 A system of 100 kg mass undergoes a process in which its specific entropy increases from 0.3 kJ/kgK to 0.4 kJ/kgK. At the same time, the entropy of the surroundings decreases from 80 kJ/K to 75 kJ/K.

The process is:

- (a) Reversible and isothermal
- (b) Irreversible
- (c) Reversible
- (d) Impossible

[ESE : 1997]

3.8 An ideal air standard cycle is shown in the given temperature-entropy diagram

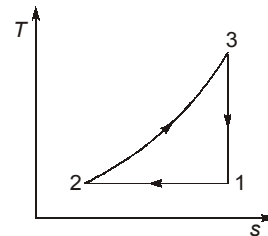

The same cycle, when represented on the pressure-volume coordinates takes the form

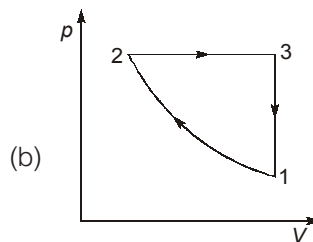
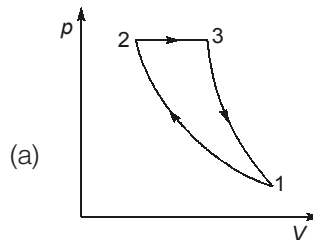

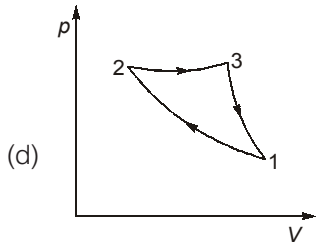
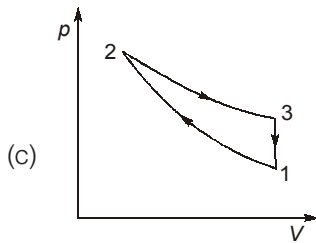

[ESE : 1997]

3.9 Four processes of a thermodynamic cycle are shown in the Figure-I on the $T-s$ plane in the sequence 1-2-3-4. The corresponding correct sequence of these processes in the $p-V$ plane shown in figure Figure-II will be

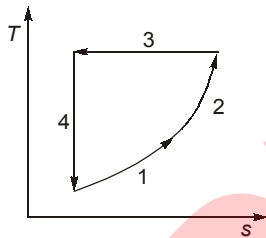

Fig.-I

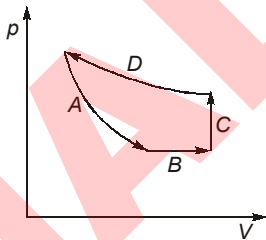

Fig.-II

- (a) C-D-A-B
- (b) C-A-B-D
- (c) A-B-C-D
- (d) B-C-D-A

[ESE : 1998]

3.10 For a thermodynamic cycle to be irreversible, it is necessary that

- (a) $\oint \frac{\delta Q}{T} = 0$
- (b) $\oint \frac{\delta Q}{T} < 0$
- (c) $\oint \frac{\delta Q}{T} > 0$
- (d) $\oint \frac{\delta Q}{T} \geq 0$

[ESE : 1998]

3.11 Consider the following statements:
In an irreversible process

1. Entropy always increases.
2. The sum of the entropy of all the bodies taking part in a process always increases.
3. Once created, entropy cannot be destroyed.

Which of these statements are correct?

- (a) 1 and 2
- (b) 1 and 3
- (c) 2 and 3
- (d) 1, 2 and 3

[ESE : 1998]

Direction: Each of the next questions consists of two statements, one labelled as the 'Assertion (A)' and the other as 'Reason (R)'. You are to examine these two statements carefully and select the answers to these items using the codes given below:

- Codes:**
- (a) Both **A** and **R** are individually true and **R** is the correct explanation of **A**
 - (b) Both **A** and **R** are individually true but **R** is not the correct explanation of **A**
 - (c) **A** is true but **R** is false
 - (d) **A** is false but **R** is true

3.12 **Assertion (A):** If a graph is plotted for absolute temperature as a function of entropy, the area under the curve would give the amount of heat supplied

Reason (R): Entropy represents the maximum fraction of work obtainable from heat per degree drop in temperature.

[ESE : 1998]

3.13 **Assertion (A):** Second law of thermodynamics is called the law of degradation of energy.

Reason (R): Energy does not degrade each time it flows through a finite temperature difference.

[ESE : 1999]



Answers Second Law, Carnot Cycle and Entropy

- 3.1 (b) 3.2 (c) 3.3 (d) 3.4 (c) 3.5 (a) 3.6 (c) 3.7 (b) 3.8 (a) 3.9 (d)
- 3.10 (b) 3.11 (c) 3.12 (c) 3.13 (c)

Explanations Second Law, Carnot Cycle and Entropy**3.1 (b)**

In p - V diagram

BC — constant pressure process

CA — constant volume process

$$\therefore \left(\frac{dT}{ds}\right)_p = \frac{T}{c_p} \quad \text{and} \quad \left(\frac{dT}{ds}\right)_v = \frac{T}{c_v}$$

$$\therefore c_p > c_v \quad \therefore \left(\frac{dT}{ds}\right)_v > \left(\frac{dT}{ds}\right)_p$$

Thus, slope of constant pressure (BC) is lower compare to slope of constant volume process (CA).

3.2 (c)

$$T \cdot dS = dU + p \cdot dV$$

All are properties thus it is applicable for reversible as well as irreversible process.

3.3 (d)

By applying steady flow energy equation for throttling process, $W = 0$, $Q = 0$

$$h_1 + \frac{C_1^2}{2} = h_2 + \frac{C_2^2}{2} = h_3 + \frac{C_3^2}{2}$$

(Assume $z_1 = z_2 = z_3$)

For gas

$$c_p T_1 + \frac{C_1^2}{2} = c_p T_2 + \frac{C_2^2}{2} = c_p T_3 + \frac{C_3^2}{2}$$

as $C \uparrow$, $T \downarrow$

From continuity equation:

$$Q = AC$$

For process 1-2:

$$\text{as } A \downarrow, C \uparrow, T \downarrow$$

For process 2-3:

$$\text{as } A \uparrow, C \downarrow, T \uparrow$$

3.4 (c)

In irreversible process entropy always increase only in option C entropy increases in both cases.

3.5 (a)

$$(\Delta S)_{\text{system}} = S_2 - S_1 = \int_1^2 \frac{\delta Q}{T} + S_{\text{gen}}$$

(S_{gen} is entropy generation i.e. some entropy is generated during irreversible process)

$$\Delta S = \int \frac{\delta Q}{T} = 0 \text{ implies adiabatic and reversible}$$

process. But if $\Delta S > 0$, it implies irreversible process.

3.6 (c)

The entropy change of the system will be zero as per Clausius inequality (principle of entropy). But the entropy change of the surrounding will be positive value.

$$(\Delta S)_{\text{total}} = (\Delta S)_{\text{system}} + (\Delta S)_{\text{surrounding}} \geq 0$$

3.7 (b)

$$m = 100 \text{ kg}$$

Entropy of system,

$$S_1 = 0.3 \times 100 = 30 \text{ kJ/K}$$

$$S_2 = 0.4 \times 100 = 40 \text{ kJ/K}$$

Entropy change of the system,

$$(\Delta S)_{\text{system}} = S_2 - S_1 = 40 - 30 = 10 \text{ kJ/K}$$

Entropy of surroundings,

$$S_1 = 80 \text{ kJ/K}$$

$$S_2 = 75 \text{ kJ/K}$$

Entropy change of the surroundings

$$(\Delta S)_{\text{surrounding}} = S_2 - S_1$$

$$(\Delta S)_{\text{surroundings}} = -5 \text{ kJ/K}$$

Entropy change of universe:

$$(\Delta S)_{\text{universe}} = (\Delta S)_{\text{system}} + (\Delta S)_{\text{surrounding}} \\ = 10 - 5 = 5 \text{ kJ/K}$$

Since $(\Delta S)_{\text{universe}} > 0$

Hence process is irreversible

3.8 (a)

In T - S diagram

Process 1-2 \rightarrow Isothermal process

Process 3-1 \rightarrow Reversible adiabatic process

Thus, on P - V diagram, slope of reversible adiabatic process (3-1) is more than slope of isothermal process (1-2).

Process 2-3 \rightarrow Isobaric process line.

3.10(b)

$\oint \frac{dQ}{T} = 0$; cycle is reversible

$\oint \frac{dQ}{T} < 0$; cycle is irreversible and possible

$\oint \frac{dQ}{T} > 0$; the cycle is impossible since it violates the second law.

3.12(c)

(A) is correct but (R) is not correct.



MADE EASY

4

Irreversibility and Availability

4.1 Consider the following statements:

1. Availability is generally conserved.
2. Availability can either be negative or positive.
3. Availability is the maximum theoretical work obtainable.
4. Availability can be destroyed in irreversibilities.

Which of these statements are correct?

- (a) 3 and 4 (b) 1 and 2
(c) 1 and 3 (d) 2 and 4

[ESE : 1996]

4.2 Neglecting changes in kinetic energy and potential energy, for unit mass the availability in a non-flow process becomes $a = \phi - \phi_0$, where ϕ is the availability function of the

- (a) open system
(b) closed system
(c) isolated system
(d) steady flow process

[ESE : 1998]

■■■■

Answers Irreversibility and Availability

4.1 (a) 4.2 (b)

Explanations Irreversibility and Availability

4.1 (a)

The availability is the maximum useful work obtainable from a system as it reaches the dead state. Conversely, availability can be regarded as the minimum work required to bring the closed system from the dead state to given state. The value of availability cannot be negative. As energy is always conserved, availability is not generally conserved but is destroyed by irreversibility.

4.2 (b)

In case of closed system, availability function is given by ϕ

But in case of nonflow process, the availability becomes $a = \phi - \phi_0$

■■■■

5

Thermodynamic Relations

5.1 Joule-Thomson coefficient is defined as

- (a) $\left(\frac{\partial T}{\partial p}\right)_h$ (b) $\left(\frac{\partial h}{\partial p}\right)_T$
 (c) $\left(\frac{\partial h}{\partial T}\right)_p$ (d) $\left(\frac{\partial p}{\partial T}\right)_h$

[ESE : 1995]

5.2 For a given volume of dry saturated steam, Clapeyron's equation is given by

- (a) $V_g - V_f = \frac{dT_s}{dp} \times \frac{T_s}{h_g - h_f}$
 (b) $V_g - V_f = \frac{dT_s}{dp} \times \frac{h_g - h_f}{T_s}$
 (c) $V_g - V_f = \frac{dp}{dT_s} \times \frac{h_g - h_f}{T_s}$
 (d) $V_g - V_f = \frac{dp}{dT_s} \times \frac{T_s}{h_g - h_f}$

[ESE : 1996]

5.3 The Joule-Thomson coefficient is the

- (a) $\left(\frac{\partial T}{\partial p}\right)_h$ of pressure-temperature curve of real gases
 (b) $\left(\frac{\partial T}{\partial s}\right)_v$ of temperature-entropy curve of real gases
 (c) $\left(\frac{\partial h}{\partial s}\right)_T$ of enthalpy-entropy curve of real gases
 (d) $\left(\frac{\partial p}{\partial T}\right)_p$ of pressure-volume curve of real gases

[ESE : 1996]

5.4 The thermodynamic parameters are:

1. Temperature
2. Specific volume
3. Pressure
4. Enthalpy
5. Entropy

The Clapeyron equation of state provides relationship between:

- (a) 1 and 2 (b) 2, 3 and 4
 (c) 3, 4 and 5 (d) 1, 2, 3 and 4

[ESE : 1997]

5.5 It can be shown that for a simple compressible substance, the relationship

$$C_p - C_v = -T \left(\frac{\partial V}{\partial T}\right)_p^2 \left(\frac{\partial p}{\partial V}\right)_T \text{ exists}$$

where C_p and C_v are specific heats at constant pressure and constant volume respectively, T is temperature, V is volume and p is pressure.

Which one of the following statements is not true?

- (a) C_p is always greater than C_v
 (b) The right side of the equation reduces to R for an ideal gas

- (c) Since $\left(\frac{\partial p}{\partial V}\right)_T$ can be either positive or

negative, and $\left(\frac{\partial V}{\partial T}\right)_p^2$ must be positive, T must have a sign that is opposite to that of

$$\left(\frac{\partial p}{\partial V}\right)_T$$

- (d) C_p is very nearly equal to C_v for liquid water
 [ESE : 1998]

5.6 Clausius-Clapeyron equation gives the 'slope' of a curve in

- (a) p - V diagram (b) p - h diagram
 (c) p - T diagram (d) T - s diagram

[ESE : 1999]

- 5.7 Joule-Thomson coefficient is the ratio of
- pressure change to temperature change occurring when a gas undergoes the process of adiabatic throttling
 - temperature change to pressure change occurring when a gas undergoes the process of adiabatic throttling
 - temperature change to pressure change occurring when a gas undergoes at the process of adiabatic compression

- pressure change to temperature change occurring when a gas undergoes the process of adiabatic compression

[ESE : 1999]

- 5.8 Gibb's free energy 'G' is defined as

- $G = H - TS$
- $G = u - TS$
- $G = u + pV$
- $G = H + TS$

[ESE : 1999]

■■■■

Answers Thermodynamic Relations

- 5.1 (a) 5.2 (b) 5.3 (a) 5.4 (d) 5.5 (c) 5.6 (c) 5.7 (b) 5.8 (a)

Explanations Thermodynamic Relations**5.1 (a)**

The numerical value of the slope of an isenthalpic curve on a T-p diagram at any point is called Joule-Thomson coefficient and is denoted by μ_j

$$\text{and } \mu_j = \left(\frac{\partial T}{\partial p} \right)_h$$

5.2 (b)

Clausius-Clapeyron equation

$$\frac{dp}{dT} = \frac{h_g - h_f}{T_s (v_g - v_f)}$$

$$v_g - v_f = \frac{dT}{dp} \left(\frac{h_g - h_f}{T_s} \right)$$

5.3 (a)

The numerical value of the slope of an isenthalpic curve on a T-p diagram at any point is called Joule-Thomson coefficient and is denoted by μ_j

$$\text{and } \mu_j = \left(\frac{\partial T}{\partial p} \right)_h$$

5.4 (d)

The Clapeyron equation is $\left(\frac{dp}{dT} \right)_{\text{sat}} = \frac{h_{fg}}{T \cdot v_{fg}}$

It enables us to determine the enthalpy of vaporization h_{fg} at a given temperature by simply measuring the slope of saturation curve on a p-T diagram and the specific volume of saturated liquid and saturated vapour at given temperature.

5.5 (c)

For any substance at constant temperature when pressure increases, volume will decrease. Thus,

$$\left(\frac{\partial p}{\partial V} \right)_T = -ve$$

5.6 (c)

Clapeyron equation $\frac{dp}{dT} = \frac{h_{fg}}{T(v_g - v_f)}$

5.7 (b)

$\left(\frac{\partial T}{\partial p} \right)_h = \mu_j$, Joule-Thomson coefficient

■■■■

6

Pure Substances

6.1 Which one of the following p - V diagrams for steam illustrates the isothermal process undergone by superheated steam till it becomes wet?

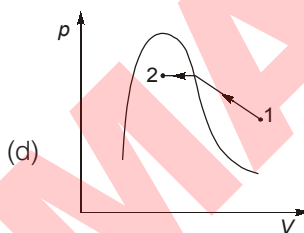
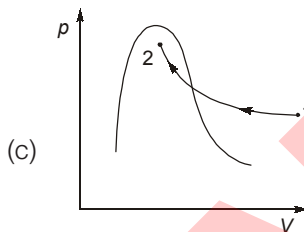
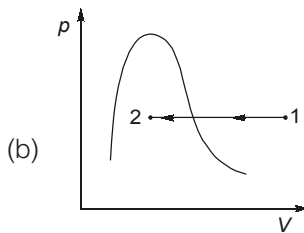
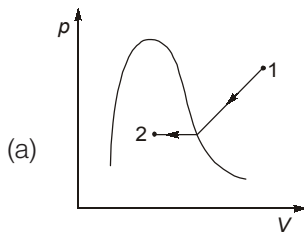

[ESE : 1995]

6.2 Match List-I (Some process of steam) with List-II (Effects due to the processes) and select the correct answer using the codes given below the lists:

List-I

- A. As saturation pressure increases
- B. As saturation temperature increases
- C. As saturation pressure decreases
- D. As dryness fraction increases

List-II

- 1. Entropy increases
- 2. Specific volume increases
- 3. Enthalpy of evaporation decreases
- 4. Saturation temperature increases

Codes:

	A	B	C	D
(a)	1	3	2	4
(b)	4	3	2	1
(c)	3	4	1	2
(d)	2	4	3	1

[ESE : 1995]

6.3 The given diagram shows the throttling process of a pure substance.

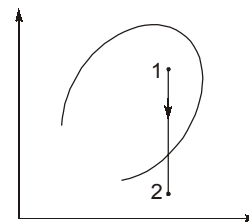

The ordinate and abscissa are respectively

- (a) pressure and volume
- (b) enthalpy and entropy
- (c) temperature and entropy
- (d) pressure and enthalpy

[ESE : 1995]

6.4 The ordinate and abscissa in the given figure showing the saturated liquid and vapour regions of a pure substance represent

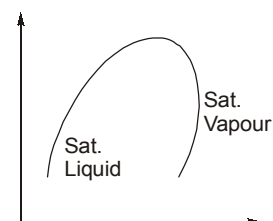

- (a) temperature and pressure
- (b) enthalpy and entropy
- (c) pressure and volume
- (d) pressure and enthalpy

[ESE : 1997]

- 6.5 A saturated vapour is compressed to half of its volume without changing its temperature. The result is that
- (a) all the vapour condenses to liquid
 - (b) some of the liquid evaporates and the pressure does not change
 - (c) the pressure is double its initial value
 - (d) some of the vapour condenses and the pressure does not change [ESE : 1997]

- 6.6 The given diagram shown as isometric cooling process 1-2 of a pure substance. The ordinate and abscissa are respectively

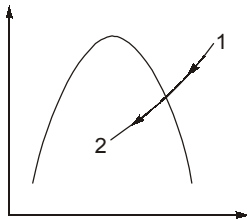

- (a) Pressure and volume
- (b) Enthalpy and entropy
- (c) Temperature and entropy
- (d) Pressure and enthalpy [ESE : 1998]

Direction: Each of the next questions consists of two statements, one labelled as the 'Assertion (A)' and the other as 'Reason (R)'. You are to examine these two statements carefully and select the answers to these items using the codes given below:

- Codes:**
- (a) Both **A** and **R** are individually true and **R** is the correct explanation of **A**

- (b) Both **A** and **R** are individually true but **R** is not the correct explanation of **A**
- (c) **A** is true but **R** is false
- (d) **A** is false but **R** is true

- 6.7 **Assertion (A):** At a given temperature, the enthalpy of superheated steam is the same as that of saturated steam.

Reason (R): The enthalpy of vapour at lower pressure is dependent on temperature alone. [ESE : 1998]

- 6.8 **Assertion (A):** Water is not a pure substance.
Reason (R): The term pure substance designates a substance which is homogeneous and has the same chemical composition in all phases. [ESE : 1999]

- 6.9 The p - V - T surface of a pure substance is shown in the given figure. The two phase regions are labelled as

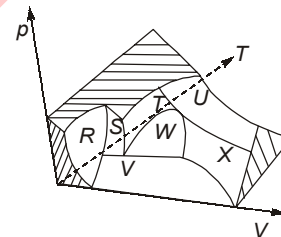

- (a) R, T and X
- (b) S, U and W
- (c) S, W and V
- (d) R, T and V

[ESE : 1999]



Answers Pure Substances

- 6.1 (d) 6.2 (b) 6.3 (d) 6.4 (d) 6.5 (d) 6.6 (b) 6.7 (d) 6.8 (d) 6.9 (c)

Explanations Pure Substances

- 6.1 (d)

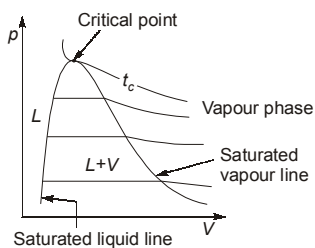

- 6.4 (d)

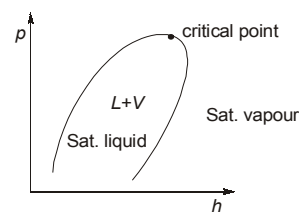

6.5 (d)

Between 1 and 2 i.e. in wet region temperature and pressure does not change independently. Hence for constant temperature process, pressure will be constant.

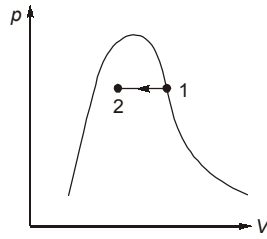

Note: We can not apply ideal gas equation in wet region.

6.7 (d)

When the temperature of the vapour is greater than the saturation temperature corresponding to the given pressure, the vapour is said to be superheated. The enthalpy of superheated steam is always greater than the enthalpy of saturated steam.

6.8 (d)

A substance that has fixed chemical composition throughout is called pure substance.

Water, nitrogen, helium and CO_2 are example for all pure substance.



MADE EASY

UNIT



Heat Transfer

Syllabus

Modes of heat transfer, Steady and unsteady heat conduction, Thermal resistance, Fins, Free and forced convection, Correlations for convective heat transfer, Radiative heat transfer – Radiation heat transfer coefficient; boiling and condensation, Heat exchanger performance analysis.

Contents

Sl.	Topic	Page No.
1.	Conduction	61
2.	Unsteady State Conduction Heat Transfer	68
3.	Heat Dissipation From Extended Surfaces (Fins)	70
4.	Free and Forced Convection	71
5.	Radiation	74
6.	Heat Exchangers	78
7.	Boiling and Condensation	81



1

Conduction

1.1 Water jacketed copper rod 'D' m in diameter is used to carry the current. The water, which flows continuously maintains the rod temperature at $T_i^\circ\text{C}$ during normal operation at 'I' amps. The electrical resistance of the rod is known to be 'R' Ω/m . If the coolant water ceased to be available and the heat removal diminished greatly, the rod would eventually melt. What is the time required for melting to occur if the melting point of the rod material is T_{mp} ? (c_p = specific heat, ρ density of the rod material and L is the length of the rod).

(a) $\rho \left(\frac{\pi D^2}{4} \right) c_p \frac{(T_{mp} - T_i)}{I^2 R}$

(b) $\frac{(T_{mp} - T_i)}{\rho I^2 R}$

(c) $\frac{\rho(T_{mp} - T_i)}{I^2}$

(d) $\frac{c_p(T_{mp} - T_i)}{I^2 R}$

[ESE : 1995]

1.2 In current carrying conductors, if the radius of the conductor is less than the critical radius, then addition of electrical insulation is desirable, as

- (a) it reduces the heat loss from the conductor and thereby enables the conductor to carry a higher current.
- (b) it increases the heat loss from the conductor and thereby enables the conductor to carry a higher current.
- (c) it increases the thermal resistance of the insulation and thereby enables the conductor to carry a higher current.
- (d) it reduces the thermal resistance of the insulation and thereby enables the conductor to carry a higher current.

[ESE : 1995]

1.3 The heat flow through a composite cylinder is given by the equation

(Symbols have the usual meaning)

(a) $Q = \frac{(T_1 - T_{n+1})2\pi L}{\sum_{n=1}^{n=n} \frac{1}{k_n} \log_e \left(\frac{r_{n+1}}{r_n} \right)}$

(b) $Q = \frac{4\pi(T_1 - T_{n+1})}{\sum_{n=1}^{n=n} \left[\frac{r_{n+1} - r_n}{k_n r_n \cdot r_{n+1}} \right]}$

(c) $Q = \frac{T_1 - T_{n+1}}{\frac{1}{A} \sum_{n=1}^{n=n} \left(\frac{L_n}{k_n} \right)}$

(d) $Q = \frac{T_1 - T_2}{\log_e \frac{r_2}{r_1} / 2\pi k L}$

[ESE : 1995]

1.4 Assertion (A): Addition of insulation to the inside surface of a pipe always reduces heat transfer rate and critical radius concept has no significance.

Reason (R): If insulation is added to the inside surface, both surface resistance and internal resistance increase.

- (a) Both **A** and **R** are individually true and **R** is the correct explanation of **A**
- (b) Both **A** and **R** are individually true but **R** is not the correct explanation of **A**
- (c) **A** is true but **R** is false
- (d) **A** is false but **R** is true

[ESE : 1995]

1.5 Heat transfer takes place according to

- (a) Zeroth Law of thermodynamics
- (b) First Law of the thermodynamics
- (c) Second Law of thermodynamics
- (d) Third Law of thermodynamics

[ESE : 1996]

- 1.6 It is desired to increase the heat dissipation rate over the surface of an electronic device of spherical shape of 5 mm radius exposed to convection with $h = 10 \text{ W/m}^2\text{K}$ by encasing it in a spherical sheath of conductivity 0.04 W/mK . For maximum heat flow, the diameter of the sheath should be
- (a) 18 mm (b) 16 mm
(c) 12 mm (d) 8 mm

[ESE : 1996]

- 1.7 A pipe carrying saturated steam, is covered with a layer of insulation and exposed to ambient air. The thermal resistance are as shown in the following figure.



Which one of the following statements is correct in this regard.

- (a) R_{steam} and R_{pipe} negligible as compared to R_{ins} and R_{air}
(b) R_{pipe} and R_{air} negligible as compared to R_{ins} and R_{steam}
(c) R_{steam} and R_{air} are negligible as compared to R_{pipe} and R_{ins}
(d) No quantitative data is provided, therefore no comparison is possible.

[ESE : 1996]

- 1.8 Match List-I with List-II and select the correct answer using the codes given below the lists:

List-I

- A. Momentum transfer
B. Mass transfer
C. Heat transfer

List-II

1. Thermal diffusivity
2. Kinematic viscosity
3. Diffusion coefficient

Codes:

- | | A | B | C |
|-----|---|---|---|
| (a) | 2 | 3 | 1 |
| (b) | 1 | 3 | 2 |
| (c) | 3 | 2 | 1 |
| (d) | 1 | 2 | 3 |

[ESE : 1996]

- 1.9 Consider the following statements:

1. Under certain conditions, an increase in thickness of insulation may increase the heat loss from a heated pipe.

2. The heat loss from an insulated pipe reaches a maximum when the outside radius of insulation is equal to the ratio of thermal conductivity to the surface heat transfer coefficient.
3. Small diameter tubes are invariably insulated.
4. Economic insulation is based on minimum heat loss from pipe.

Which of these statements are correct?

- (a) 1 and 3 (b) 1 and 2
(c) 2 and 4 (d) 3 and 4

[ESE : 1996]

- 1.10 A cube at high temperature is immersed in a constant temperature bath. It loses heat from its top, bottom and side surfaces with heat transfer coefficient of h_1 , h_2 and h_3 respectively. The average heat transfer coefficient for the cube is

- (a) $h_1 + h_2 + h_3$ (b) $(h_1 h_2 h_3)^{1/3}$
(c) $\frac{1}{h_1} + \frac{1}{h_2} + \frac{1}{h_3}$ (d) None of these

[ESE : 1996]

- 1.11 A steam pipe is covered with two layers of insulating materials, with the better insulating material forming the outer part. If the two layers are interchanged, the heat conducted

- (a) will decrease
(b) will increase
(c) will remain unaffected
(d) may increase or decrease depending upon the thickness of each layer

[ESE : 1997]

- 1.12 In a large plate, the steady temperature distribution is as shown in the figure below. If no heat is generated in the plate, the thermal conductivity k will vary as (T is temperature and α is a constant)

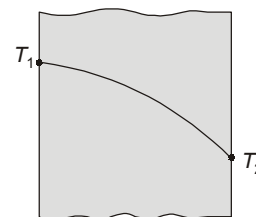

- (a) $k_0(1 + \alpha T)$ (b) $k_0(1 - \alpha T)$
(c) $k_0 + \alpha T$ (d) $k_0 - \alpha T$

[ESE : 1997]

1.13 A composite wall consists of two layers of different materials having conductivities k_1 and k_2 . For equal thickness of the two layers, the equivalent thermal conductivity of the slab will be

- (a) $k_1 + k_2$ (b) $k_1 k_2$
 (c) $\frac{2k_1 k_2}{k_1 + k_2}$ (d) $\frac{k_1 + k_2}{k_1 k_2}$

[ESE : 1997]

1.14 Solar energy is absorbed by the wall of a building as shown in the figure below. Assuming that the ambient temperature inside and outside are equal and considering steady-state, the equivalent circuit will be as show in

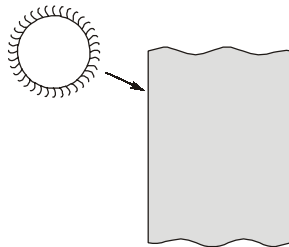

Symbols:

$R_{co} = R_{\text{convection outside}}$

$R_{ci} = R_{\text{convection inside}}, R_w = R_{\text{wall}}$

- (a)
- (b)
- (c)
- (d)

[ESE : 1998]

1.15 Consider the following statements:
 The Fourier heat conduction equation

$Q = -kA \frac{dT}{dx}$, Presumes

1. steady-state conditions.

2. constant value of thermal conductivity.
 3. uniform temperatures at the wall surfaces.
 4. one-dimensional heat flow.

Which of these statements are correct?

- (a) 1, 2 and 3 (b) 1, 2 and 4
 (c) 2, 3 and 4 (d) 1, 3 and 4

[ESE : 1998]

1.16 The temperature variation in a large plate, as shown in the below figure, would correspond to which of the following condition (s)?

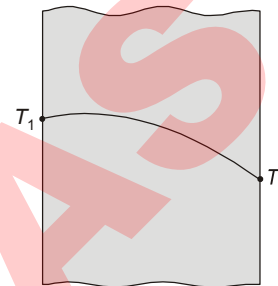

1. Unsteady heat.
 2. Steady-state with variation of k .
 3. Steady-state with heat generation.

Select the correct answer using the codes given below:

- (a) 2 alone (b) 1 and 2
 (c) 1 and 3 (d) 1, 2 and 3

[ESE : 1998]

1.17 In a long cylindrical rod of radius R and a surface heat flux of q_0 , the uniform internal heat generation rate is

- (a) $2 q_0/R$ (b) $2 q_0$
 (c) q_0/R (d) $2q_0/R^2$

[ESE : 1998]

1.18 A furnace wall is constructed as shown in the below figure. The interface temperature T_i will be

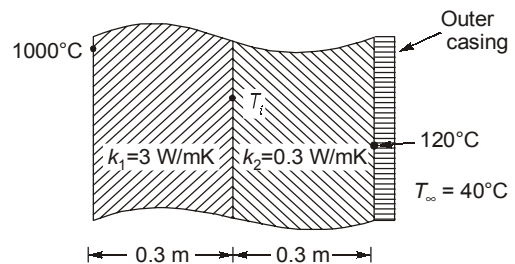

- (a) 560°C (b) 200°C
 (c) 920°C (d) 1120°C

[ESE : 1998]

1.19 Temperature profiles for four cases are shown in the following figures and are labelled A, B, C and D.

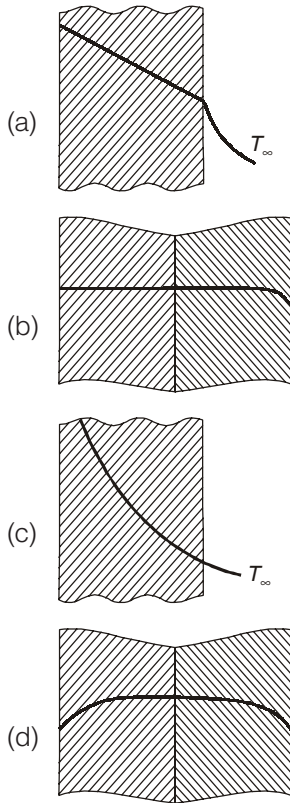

- Match the above figures with
1. High conductivity fluid
 2. Low conductivity fluid
 3. Insulating body
 4. Guard heater

Select the correct answer using the codes given below:

Codes:

	A	B	C	D
(a)	1	2	3	4
(b)	2	3	1	4
(c)	1	2	4	3
(d)	2	1	4	3

[ESE : 1998]

1.20 Heat is mainly transferred by conduction, convection and radiation in

- (a) insulated pipes carrying hot water
- (b) refrigerator freezer coil
- (c) boiler furnaces
- (d) condensation of steam in a condenser

[ESE : 1998]

1.21 The heat flow equation through a cylinder of inner radius ' r_1 ' and outer radius ' r_2 ' is desired in the same form as that for heat flow through a plane wall. The equivalent area A_m is given by

- (a) $\frac{A_1 + A_2}{\log_e(A_2/A_1)}$
- (b) $\frac{A_1 + A_2}{2\log_e(A_2/A_1)}$
- (c) $\frac{A_2 - A_1}{2\log_e(A_2/A_1)}$
- (d) $\frac{A_2 - A_1}{\log_e(A_2/A_1)}$

[ESE : 1999]

1.22 A furnace wall is constructed as show in the figure below. That heat transfer coefficient across the outer casing will be

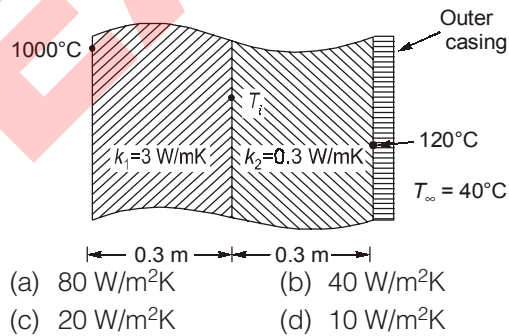

- (a) 80 W/m²K
- (b) 40 W/m²K
- (c) 20 W/m²K
- (d) 10 W/m²K

[ESE : 1999]

1.23 A steel plate of thickness 5 cm and thermal conductivity 20 W/mK is subjected to a uniform heat flux of 800 W/m² on one surface A and transfers heat by convection with a heat transfer coefficient of 80 W/m²K from the other surface B into the ambient air at T_∞ of 25°C. The temperature of the surface B transferring heat by convection is

- (a) 25°C
- (b) 35°C
- (c) 45°C
- (d) 55°C

[ESE : 1999]



Answers Conduction

- 1.1 (a) 1.2 (b) 1.3 (a) 1.4 (a) 1.5 (c) 1.6 (b) 1.7 (a) 1.8 (a) 1.9 (b)
- 1.10 (a) 1.11 (a) 1.12 (a) 1.13 (c) 1.14 (*) 1.15 (d) 1.16 (d) 1.17 (a) 1.18 (c)
- 1.19 (b) 1.20 (c) 1.21 (d) 1.22 (d) 1.23 (b)

Explanations Conduction**1.1 (a)**

$$Q = I^2 R t = m c_p \Delta T$$

$$t = \frac{m c_p \Delta T}{I^2 R} \quad (\Delta T = T_{mp} - T_l)$$

$$t = \frac{\rho \left(\frac{\pi}{4} d^2 \right) c_p (T_{mp} - T_l)}{I^2 R}$$

1.2 (b)

In current carrying conductor heat dissipation is the main objective of insulation. So if radius of conductor is less than critical radius, then addition of insulation upto critical radius will lead to increase in heat transfer.

1.3 (a)

$$Q = \frac{(T_1 - T_{n+1}) 2\pi L}{\sum_{n=1}^{n=n} \frac{1}{k_n} \log_e \left(\frac{r_{n+1}}{r_n} \right)}$$

(For composite cylinder)

$$Q = \frac{4\pi (T_1 - T_{n+1})}{\sum_{n=1}^{n=n} \left[\frac{r_{n+1} - r_n}{k_n \cdot r_n \cdot r_{n+1}} \right]}$$

(For composite sphere)

1.4 (a)

When insulation is added to the inside surface then surface area reduces due to decrease in bore of the pipe. Hence convection resistance ($1/hA$) increases. Also due to insulation on the inner surface conduction resistance will increase. So overall resistance of the pipe will always increase and hence heat transfer will always decrease.

1.5 (c)

Heat transfer takes place according to second law of thermodynamics.

Second law of thermodynamics states that "heat will flow naturally from one reservoir to another at a lower temperature, but not in opposite direction without assistance".

1.6 (b)

Critical radius for sphere,

$$r_c = \frac{2k}{h} = \frac{2 \times 0.04}{10} = 0.008 \text{ m}$$

\therefore Diameter = $2r_c = 16 \text{ mm}$

1.7 (a)

In usual analysis R_{ins} and R_{air} are larger magnitude than R_{pipe} and R_{steam} .

1.8 (a)

Momentum transfer — Kinematic viscosity

Kinematic viscosity: $\nu = \frac{\mu}{\rho}$

Mass transfer — Diffusion coefficient

Molecular diffusion is governed by Fick's law

$$N_A = \frac{m_A}{A} = -D_{AB} \frac{dc_A}{dx}$$

where, N_A = mass flux of species A

D_{AB} = Diffusion coefficient

$\frac{dc_A}{dx}$ = Concentration of gradient for species A

Heat transfer — Thermal diffusivity

Thermal diffusivity: $\alpha = \frac{k}{\rho c_p}$

1.9 (b)

If $r_o < r_c$

An increase in thickness of insulation increases the heat loss.

If $r_o = r_c$

The heat loss from an insulated pipe reaches

a maximum value when the outside radius of insulation is equal to the ratio of thermal conductivity to the surface heat transfer coefficient.

For cylinder, $r_c = k/h$.

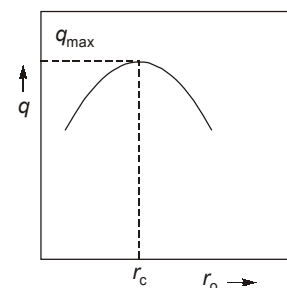

1.10 (a)

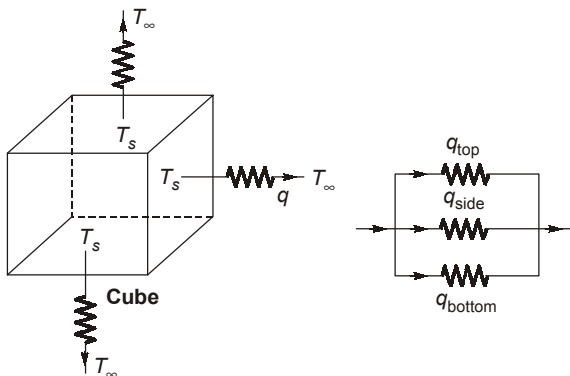

Parallel connections,

$$\bar{h} = h_1 + h_2 + h_3$$

1.11 (a)

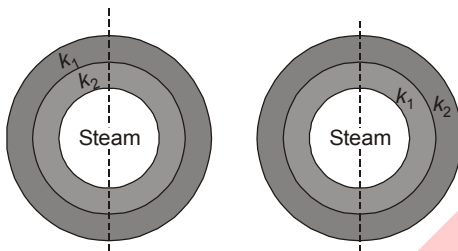

$k_1 < k_2$ [k_1 better insulator]

$$Q \propto \frac{k.A.\Delta T}{\ln\left(\frac{r_2}{r_1}\right)}$$

$\therefore Q \propto k$

This means that the material having better insulating material should be inside to minimize the heat flux. If higher 'k' material then 'Q' is more since total thermal resistance is lesser.

1.12 (a)

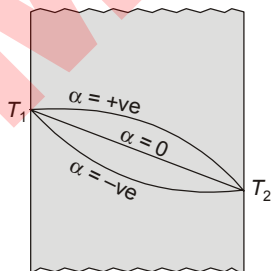

For positive value of α , the temperature profile curve is convex and curve would be concave for negative value of coefficient α .

$$\therefore k = k_0 [1 + \alpha T]$$

1.13 (c)

$$R_{eq} = R_1 + R_2$$

$$\frac{L_{eq}}{k_{eq}A} = \frac{L_1}{k_1A} + \frac{L_2}{k_2A}$$

Since $L_1 = L_2 = L$

$$\frac{2L}{k_{eq}} = \frac{L}{k_1} + \frac{L}{k_2}$$

$$\frac{k_{eq}}{2} = \frac{k_1 k_2}{k_1 + k_2}$$

$$k_{eq} = \frac{2k_1 k_2}{k_1 + k_2}$$

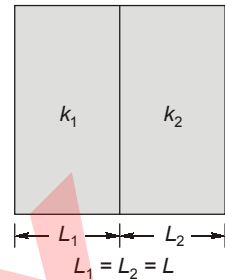

1.14 (a)

All of the options are wrong.

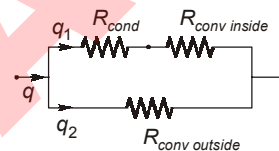

1.15 (d)

Assumptions associated with Fourier's law of heat conduction

1. Steady state conditions.
2. One dimensions heat flow.
3. Uniform temperatures at the wall surfaces.

1.16 (d)

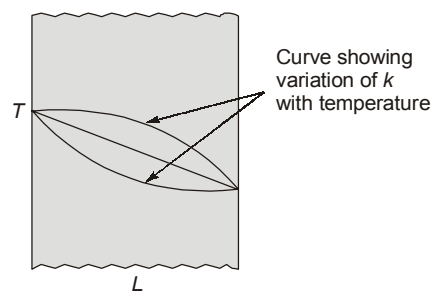

1.17 (a)

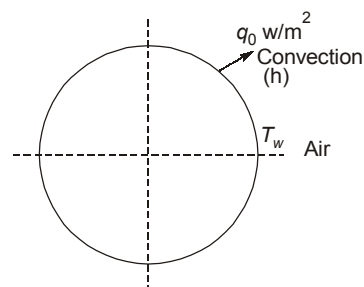

For steady state conditions of rod,
Heat convected from surface = Heat generated in rod

Heat flux \times area = Heat generated

$$q_0 \times 2\pi RL = q_{\text{gen}} \times \pi R^2 L$$

$$\Rightarrow q_{\text{gen}} = \frac{2q_0}{R} \text{ W/m}^3$$

1.18 (c)

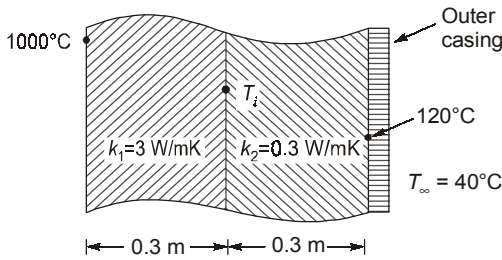

$$\frac{1000 - T_i}{\left(\frac{0.3}{3}\right)} = \frac{T_i - 120}{\left(\frac{0.3}{0.3}\right)}$$

$$1000 - T_i = 0.1 T_i - 12$$

$$1.1 T_i = 1012$$

$$T_i = 920^\circ\text{C}$$

1.19 (b)

For higher thermal conductivity, temperature drop should be less.

Guard heater will be the case of internal heat generation.

1.20 (c)

Because for radiation to be comparable the magnitude of temperature difference should be large enough. Convection & conduction is also predominant in boiler furnace.

1.21 (d)

$$q = k\Delta T \frac{2\pi l}{\ln\left(\frac{r_2}{r_1}\right)}$$

$$= k\Delta T 2\pi l \frac{(r_2 - r_1)}{(r_2 - r_1)} \frac{1}{\ln\left(\frac{2\pi r_2 l}{2\pi r_1 l}\right)}$$

$$= k\Delta T \frac{(A_2 - A_1)}{(r_2 - r_1)} \frac{1}{\ln\left(\frac{A_2}{A_1}\right)}$$

$$= \frac{k\Delta T}{(r_2 - r_1)} \left(\frac{A_2 - A_1}{\ln\left(\frac{A_2}{A_1}\right)} \right) \Rightarrow \frac{k\Delta T A_{lm}}{L_r}$$

Hence, $A_{lm} = \frac{A_2 - A_1}{\ln\left(\frac{A_2}{A_1}\right)}$

1.22 (d)

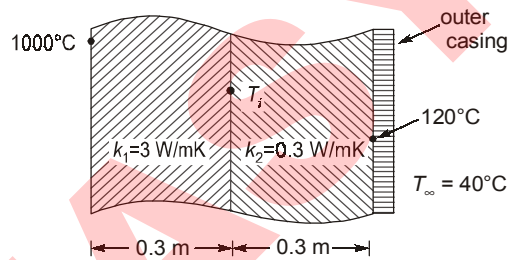

$$q = h \times (120 - 40) = \frac{1000 - 120}{\frac{0.3}{3} + \frac{0.3}{0.3}}$$

or $h = 10 \text{ W/m}^2\text{K}$

1.23 (b)

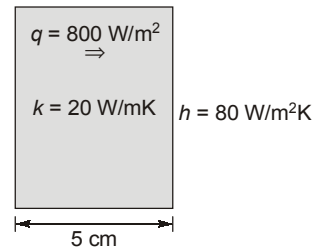

Since heat flux remain constant

$$q = \frac{Q}{A} = h(T_B - 25)$$

$$800 = 80 (T_B - 25)$$

$$T_B = 35^\circ\text{C}$$

■■■■

2

Unsteady State Conduction Heat Transfer

2.1 Match **List-I** (Parameter) with **List-II** (Definition) and select answer using the codes given below the lists:

List-I

- A. Time constant of a thermometer of radius r_o
- B. Biot number for a sphere of radius r_o
- C. Critical thickness of insulation for a wire of radius r_o
- D. Nusselt number for a sphere of radius r_o

List-II

- 1. $\frac{hr_o}{k_{\text{fluid}}}$
- 2. $\frac{k}{h}$
- 3. $\frac{hr_o}{3k_{\text{solid}}}$
- 4. $\frac{h\rho r_o l}{\rho CV}$

Nomenclature: h : film heat transfer coefficient, k_{solid} : thermal conductivity of solid k_{fluid} : thermal conductivity of fluid, ρ : density, c : specific heat, V : volume, l : length.

Codes:

	A	B	C	D
(a)	4	3	2	1
(b)	1	2	3	4
(c)	2	3	4	1
(d)	4	1	2	3

[ESE : 1995]

2.2 A solid copper ball of mass 500 grams, when quenched in a water bath at 30°C, cools from 530°C to 430°C in 10 seconds. What will be the temperature of the ball after the next 10 seconds?
 (a) 300°C (b) 320°C
 (c) 350°C
 (d) Not determinable for want of sufficient data

[ESE : 1997]

2.3 The time constant of a thermocouple is the time taken to attain
 (a) the final value to be measured
 (b) 50% of the value of the initial temperature difference
 (c) 63.2% of the value of the initial temperature difference
 (d) 98.8% of the value of the initial temperature difference

[ESE : 1997]

2.4 A thermocouple in a thermowell measures the temperature of hot gas flowing through the pipe. For the most accurate measurement of temperature, the thermowell should be made of
 (a) steel (b) brass
 (c) copper (d) aluminium

[ESE : 1997]



Answers Unsteady State Conduction Heat Transfer

2.1 (a) 2.2 (c) 2.3 (c) 2.4 (a)

Explanations Unsteady State Conduction Heat Transfer**2.1 (a)**

$$\text{Biot number} = \frac{hr_0}{k_{\text{solid}}}$$

$$\text{Nusselt number} = \frac{hr_0}{k_{\text{fluid}}}$$

Critical thickness of insulation of a wire

$$r_0 = \frac{k}{h}$$

$$\text{Time constant} = \frac{\rho CV}{hA}$$

where, V = Volume; A = Area

2.2 (c)

This is the case of unsteady state heat conduction.

T_f = Fluid temperature

T_0 = Initial temperature

T = Temperature after elapsing time ' τ '

Heat transferred = Change in Internal energy

$$hA(T - T_f) = -mc_p \left(\frac{dT}{dt} \right)$$

This is derived to.

$$\frac{\theta}{\theta_0} = e^{-\frac{hA}{\rho c_p V} \tau}$$

$$\text{or } \frac{T - T_\infty}{T_0 - T_\infty} = e^{-\frac{hA}{\rho c_p V} \tau}$$

$$\text{or } \frac{430 - 30}{530 - 30} = 0.8$$

$$= e^{-\frac{hA}{\rho c_p V} \tau} \quad (\tau = 10 \text{ sec})$$

After 20 sec (2τ):

$$\frac{T - 30}{530 - 30} = e^{-\frac{hA}{\rho c_p V} (2\tau)} = \left(e^{-\frac{hA}{\rho c_p V} \tau} \right)^2$$

$$\text{or } \frac{T - 30}{500} = (0.8)^2 = 0.64$$

$$\therefore T = 350^\circ\text{C}$$

2.3 (c)

Time constant of the thermocouple represents the time required for the thermo couple to record 63.2% of initial temperature difference.

■■■■

3

Heat Dissipation From Extended Surfaces (Fins)

3.1 Consider the following statements pertaining to heat transfer through fins:

1. Fins are equally effective irrespective of whether they are on the hot side or cold side of the fluid.
2. The temperature along the fin is variable and hence the rate of heat transfer varies along the elements of the fin.
3. The fins may be made of materials that have a higher thermal conductivity than the material of the wall.
4. Fins must be arranged at right angles to the direction of flow of the working fluid.

Which of these statements are correct?

- (a) 1 and 2 (b) 1 and 3
(c) 2 and 4 (d) 2 and 3 [ESE : 1996]

3.2 Addition of fin to the surface increases the heat transfer if $\sqrt{hA/kP}$ is

- (a) equal to one
(b) greater than one
(c) less than one
(d) greater than one but less than two.

[ESE : 1996]

3.3 A fin length l protrudes from a surface held at temperature t_0 greater than the ambient temperature t_a . The heat dissipation from the free end of the fin is assumed to be negligible. The

temperature gradient at the fin tip $\left(\frac{dt}{dx}\right)_{x=l}$ is

- (a) Zero (b) $\frac{t_l - t_a}{t_0 - t_l}$
(c) $h(t_0 - t_l)$ (d) $\frac{t_0 - t_l}{l}$ [ESE : 1999]

■■■■

Answers Heat Dissipation From Extended Surfaces (FINS)

3.1 (d) 3.2 (c) 3.3 (a)

Explanations Heat Dissipation From Extended Surfaces (FINS)

3.1 (d)

Since effectiveness of fin is given by

$$\epsilon_{\text{fin}} = \frac{km}{h}$$

Hence fin will be more effective on the side where heat transfer coefficient (h) is less.

Fins are made up of material as that of base metal is integral but higher thermal conductivity metal are preferable as temperature drop will be close to uniform temperature (ideal fin material $k = \infty$)

3.2 (c)

$\epsilon_{\text{fin}} = \sqrt{\frac{kP}{hA}}$ it should be greater than one but in

given question $\frac{1}{\epsilon_{\text{fin}}}$ is given so it should be less than one.

3.3 (a)

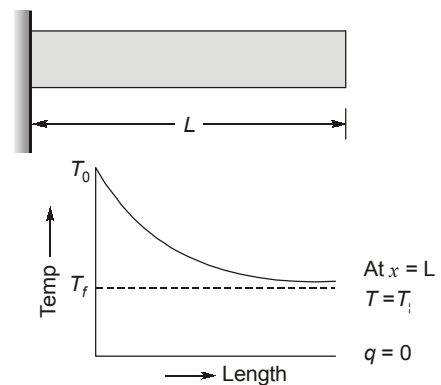

Hence, at the end of fin, temperature gradient is negligible.

■■■■

4

Free and Forced Convection

4.1 Match **List-I** (Flow pattern) with **List-II** (Situation) and select answer using the codes given below the lists:

List-I

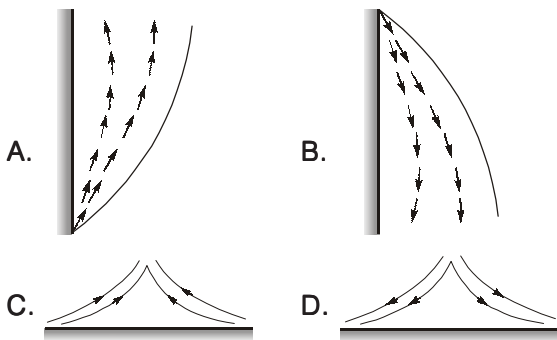

List-II

1. Heated horizontal plate
2. Cooled horizontal plate
3. Heated vertical plate
4. Cooled vertical plate

Codes:

	A	B	C	D
(a)	4	3	2	1
(b)	3	4	1	2
(c)	3	4	2	1
(d)	4	3	1	2

[ESE : 1995]

Direction: Each of the next consists of two statements, one labelled as the '**Assertion (A)**' and the other as '**Reason (R)**'. You are to examine these two statements carefully and select the answers to these items using the codes given below:

Codes:

- (a) Both **A** and **R** are individually true and **R** is the correct explanation of **A**
- (b) Both **A** and **R** are individually true but **R** is not the correct explanation of **A**
- (c) **A** is true but **R** is false
- (d) **A** is false but **R** is true

4.2 **Assertion (A):** When heat is transferred from a cylinder in cross flow to an air stream, the local heat transfer coefficient at the forward stagnation point is large.

Reason (R): Due to separation of the boundary layer eddies continuously sweep the surface close to the forward stagnation point.

[ESE : 1995]

4.3 **Assertion (A):** A slab of finite thickness heated on the one side and held horizontal will lose more heat per unit time to the cooler air if the hot surface faces upwards when compared with the case when the hot surface faces downwards.

Reason (R): When the hot surface faces upwards, convection takes place easily whereas when the hot surface faces downwards, heat transfer is mainly by conduction through air.

[ESE : 1996]

4.4 Match **List-I** with **List-II** and select the correct answer using the codes given below the lists:

List-I

- A. Reynolds Number
- B. Prandtl Number
- C. Nusselt Number
- D. Mach Number

List-II

1. Film coefficient, pipe diameter, thermal conductivity
2. Flow velocity, acoustic velocity.
3. Heat capacity, dynamic viscosity, thermal conductivity.
4. Flow velocity, pipe diameter, kinematic viscosity.

Codes:

	A	B	C	D
(a)	4	1	3	2
(b)	4	3	1	2
(c)	2	3	1	4
(d)	2	1	3	4

[ESE : 1996]

4.5 Consider the development of laminar boundary layer for a moving non-reacting fluid in contact with a flat plate of length 'L' along the flow direction. The average value of heat transfer coefficient can be obtained by multiplying the local heat transfer coefficient at the trailing edge by the factor

- (a) 0.75 (b) 1.0
(c) 1.5 (d) 2.0 [ESE : 1996]

4.6 When there is flow of fluid over a flat plate of length L, the average heat transfer coefficient is given by

- (a) $\int_0^L h_x dx$ (b) $\frac{d}{dx}(h_x)$
(c) $\frac{1}{L} \int_0^L h_x dx$ (d) $\frac{k}{L} \int_0^L Nu_x dx$
[ESE : 1997]

4.7 When all the conditions are identical, in the case of flow through pipes with heat transfer, the velocity profile will be identical for

- (a) liquid heating and liquid cooling
(b) gas heating and gas cooling
(c) liquid heating and gas cooling
(d) heating and cooling of any fluid [ESE : 1997]

4.8 In the case of turbulent flow through a horizontal isothermal cylinder of diameter 'D' free convection heat transfer coefficient for the cylinder will

- (a) be independent of diameter
(b) vary as $D^{3/4}$
(c) vary as $D^{1/4}$
(d) vary as $D^{1/2}$ [ESE : 1997]

4.9 Given that

Pr = Prandtl number

Nu = Nusselt number

Sh = Sherwood number

Re = Reynolds number

Sc = Schmidt number and

Gr = Grashoff number

the functional relationship for free convective mass transfer is given as:

- (a) $Nu = f(Gr, Pr)$ (b) $Sh = f(Sc, Gr)$
(c) $Nu = f(Re, Pr)$ (d) $Sh = f(Re, Sc)$

[ESE : 1997]

4.10 Match the velocity profiles labelled, A, B, C, and D with the following situations:

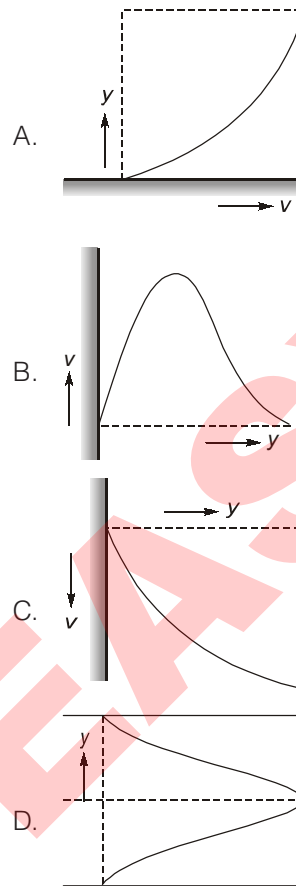

1. Natural convection.
2. Condensation.
3. Forced convection.
4. Bulk viscosity \neq wall viscosity.
5. Flow in pipe entrance.

Select the correct answer using the codes given below:

Codes:

	A	B	C	D
(a)	3	2	1	5
(b)	1	4	2	3
(c)	3	2	1	4
(d)	2	1	5	3

[ESE : 1998]

4.11 Heat is lost from a 100 mm diameter steam pipe placed horizontally in ambient at 30°C. If the Nusselt number is 25 and thermal conductivity of air is 0.03 W/mK, then the heat transfer coefficient will be

- (a) 7.5 W/m²K (b) 16.2 W/m²K
(c) 25.2 W/m²K (d) 30 W/m²K

[ESE : 1999]

4.12 For laminar flow over a flat plate, the local heat transfer coefficient h_x varies as $x^{-1/2}$, where x is the distance from the leading edge ($x = 0$) of the plate. The ratio of the average coefficient h_a

between the leading edge and some location A at $x = x$ on the plate to the local heat transfer coefficient h_x at A is

- (a) 1 (b) 2
(c) 4 (d) 8 [ESE : 1999]

■■■■

Answers Free and Forced Convection

- 4.1 (b) 4.2 (a) 4.3 (a) 4.4 (b) 4.5 (d) 4.6 (c) 4.7 (a) 4.8 (a) 4.9 (b)
4.10 (c) 4.11 (a) 4.12 (b)

Explanations Free and Forced Convection

4.1 (b)

As the colder particles come in contact with hotter body, they get heated up. Due to heating particles become lighter and rise in upward direction and opposite will happen when hotter particles come in contact with colder body.

4.3 (a)

When the hot face is facing downward then the upward motion of air is impeded by plate.

4.4 (b)

$$\text{Reynold number} = \frac{UD}{\nu}$$

U = Velocity

$$\nu = \text{Kinematic viscosity} = \frac{\mu}{\rho}$$

$$\text{Prandtl number} = \frac{\mu c_p}{k}$$

$$\text{Nusselt number} = \frac{hD}{k}$$

$$\text{Mach number} = \frac{V}{C} = \frac{\text{Flow velocity}}{\text{Acoustic velocity}}$$

4.5 (d)

$$h_{\text{avg}} = 2 h_{\text{local}}$$

4.6 (c)

$$h_{\text{avg}} = \frac{1}{L} \int_0^L h_x \cdot dx \quad A = 1 \times L \text{ m}^2$$

$$Q = h_{\text{avg}} \times A \times \Delta T = \int h_x \cdot dx \cdot \Delta T$$

$$h_{\text{avg}} = \frac{1}{L} \int h_x \cdot dx$$

4.7 (a)

When all the conditions are identical, in the case of flow through pipes with heat transfer, the velocity profile will be identical for liquid heating and liquid cooling.

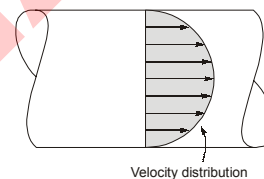

4.8 (a)

$$Nu = f(Gr \cdot Pr)^{1/3}$$

$$Gr = \frac{g\beta\Delta TD^3}{\nu^2}; \quad Nu = \frac{hD}{K} = D$$

h is independent of D .

4.9 (b)

For free convection mass transfer

$$Sh = f(Sc, Gr)$$

4.11 (a)

$$Nu = \frac{hd}{k} = 25$$

$$h = \frac{25 \times 0.03}{100 \times 10^{-3}} = 7.5 \text{ W/m}^2\text{K}$$

4.12 (b)

For laminar flow over flat plate

$$\left[\frac{h_{\text{av}}}{h_{\text{local}}} \right]_{\text{at } x=x} = 2$$

■■■■

5.1 Consider the following statements:

1. Temperature of the surface.
2. Emissivity of the surface.
3. Temperature of the air in the room.
4. Length and diameter of the pipe.

The parameter(s) responsible for loss of heat from at hot surface in a room would include

- (a) 1 only (b) 1 and 2
(c) 1, 2 and 3 (d) 1, 2, 3 and 4

[ESE : 1995]

5.2 Match List-I with List-II and select answer using the codes given below the lists:

List-I

- A. Infinite parallel planes
- B. Completely enclosed body large compared to enclosing body (Subscript 1 for enclosed body)
- C. Two rectangles with common side perpendicular to each other
- D. Concentric cylinders

List-II

1. ϵ_1
2. $\epsilon_1 \epsilon_2$
3. $\frac{1}{\frac{1}{\epsilon_1} + \frac{1}{\epsilon_2} - 1}$
4. $\frac{1}{\frac{1}{\epsilon_1} + \frac{A_1}{A_2} \left(\frac{1}{\epsilon_2} - 1 \right)}$

Codes:

- | | A | B | C | D |
|-----|---|---|---|---|
| (a) | 1 | 2 | 4 | 3 |
| (b) | 3 | 1 | 4 | 2 |
| (c) | 2 | 1 | 3 | 4 |
| (d) | 3 | 1 | 2 | 4 |

[ESE : 1995]

5.3 Match List-I with List-II and select the correct answer using the codes given below the lists:

List-I

- A. Window glass
- B. Gray Surface
- C. Carbon dioxide
- D. Radiosity

List-II

1. Emissivity independent of wavelength
2. Emission and absorption limited to certain bands of wavelength
3. Rate at which radiation leaves a surface
4. Transparency to short wave radiation

Codes:

- | | A | B | C | D |
|-----|---|---|---|---|
| (a) | 1 | 4 | 2 | 3 |
| (b) | 4 | 1 | 3 | 2 |
| (c) | 4 | 1 | 2 | 3 |
| (d) | 1 | 4 | 3 | 2 |

[ESE : 1996]

5.4 **Assertion (A):** The nose of aeroplane is painted black.

Reason (R): Black body absorbs maximum heat which is generated by aerodynamic heating when the plane is flying.

- (a) Both **A** and **R** are individually true and **R** is the correct explanation of **A**
- (b) Both **A** and **R** are individually true but **R** is not the correct explanation of **A**
- (c) **A** is true but **R** is false
- (d) **A** is false but **R** is true

[ESE : 1996]

5.5 Sun's surface at 5800 K emits radiation at a wavelength of 0.5μ . A furnace at 300°C will emit through a small opening, radiation at a wavelength of nearly

- (a) 10μ (b) 5μ
(c) 0.25μ (d) 0.025μ

[ESE : 1997]

- 5.6 Consider two infinitely long blackbody concentric cylinders with a diameter ratio $D_2/D_1 = 3$. The shape factor for the outer cylinder with itself will be

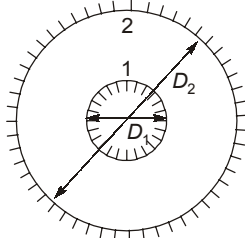

- (a) 0 (b) 1/3
(c) 2/3 (d) 1 [ESE : 1997]

- 5.7 A large spherical enclosure has a small opening. The rate of emission of radiative flux through this opening is 7.35 kW/m^2 . The temperature at the inner surface of the sphere will be about (assume Stefan Boltzmann constant $\sigma = 5.67 \times 10^{-8} \text{ W/m}^2\text{K}^4$)
- (a) 600°C (b) 330°C
(c) 373 K (d) 1000 K [ESE : 1998]

- 5.8 The spectral emissive power E_λ for a diffusely emitting surface is

1. $E_\lambda = 0$ for $\lambda \leq 3 \mu\text{m}$
2. $E_\lambda = 150 \text{ W/m}^2\mu\text{m}$ for $3 < \lambda < 12 \mu\text{m}$
3. $E_\lambda = 300 \text{ W/m}^2\mu\text{m}$ for $12 < \lambda < 25 \mu\text{m}$
4. $E_\lambda = 0$ for $\lambda > 25 \mu\text{m}$

The total emissive power of the surface over the entire spectrum is

- (a) 1250 W/m^2 (b) 2500 W/m^2
(c) 4000 W/m^2 (d) 5250 W/m^2 [ESE : 1998]

- 5.9 Consider the following statements:

1. For metals, the value of absorptivity is high.
2. For non-conducting materials, reflectivity is low.
3. For polished surfaces, reflectivity is high.
4. For gases, reflectivity is very low.

Which of these statements are correct?

- (a) 2, 3 and 4 (b) 3 and 4
(c) 1, 2 and 4 (d) 1 and 4 [ESE : 1998]

- 5.10 On a summer day, a scooter rider feels more comfortable while on the move than while at a stop light because
- (a) an object in motion captures less solar radiation
(b) air is transparent to radiation and hence it is cooler than the body

- (c) more heat is lost by convection and radiation while in motion
(d) air has a low specific heat and hence it is cooler [ESE : 1998]

- 5.11 Assertion (A): In a furnace, reradiation from the walls has the same wavelength as the incident radiation from the heat source.

Reason (R): Surfaces at the same temperature radiate at the same wavelength.

- (a) Both A and R are individually true and R is the correct explanation of A
(b) Both A and R are individually true but R is not the correct explanation of A
(c) A is true but R is false
(d) A is false but R is true [ESE : 1998]

- 5.12 A spherical aluminium shell of inside diameter 2 m is evacuated and used as radiation test chamber. If the inner surface is coated with carbon black and maintained at 600 K , the irradiation on a small test surface placed inside the chamber is (Stefan-Boltzmann constant $\sigma = 5.67 \times 10^{-8} \text{ W/m}^2\text{K}^4$)

- (a) 1000 W/m^2 (b) 3400 W/m^2
(c) 5680 W/m^2 (d) 7348 W/m^2

[ESE : 1999]

- 5.13 Match List-I (Law) with List-II (Equation) and select the correct answer using the codes given below the lists:

List-I

- A. Stefan-Boltzmann law
B. Newton's law of cooling
C. Fourier's law
D. Kirchoff's law

List-II

1. $q = hA(T_1 - T_2)$
2. $E = \alpha E_b$
3. $q = \frac{kA}{L}(T_1 - T_2)$
4. $q = \sigma A(T_1^4 - T_2^4)$
5. $q = kA(T_1 - T_2)$

Codes:

- | | A | B | C | D |
|-----|---|---|---|---|
| (a) | 4 | 1 | 3 | 2 |
| (b) | 4 | 5 | 1 | 2 |
| (c) | 2 | 1 | 3 | 4 |
| (d) | 2 | 5 | 1 | 4 |

[ESE : 1999]

5.14 If the temperature of a solid surface changes from 27°C to 627°C, then its emissive power will increase in the ratio of

- (a) 3 (b) 9
(c) 27 (d) 81

[ESE : 1999]



Answers Radiation

- 5.1 (d) 5.2 (d) 5.3 (c) 5.4 (c) 5.5 (b) 5.6 (c) 5.7 (b) 5.8 (d) 5.9 (a)
5.10 (c) 5.11 (d) 5.12 (d) 5.13 (a) 5.14 (d)

Explanations Radiation

5.1 (d)

If considering radiation heat transfer

$$Q = \sigma \epsilon A (T_1^4 - T_2^4)$$

and $A = \pi DL$

Hence heat transfer will depend upon

- Temperature of the surface and surrounding
- Emissivity of the surface
- Length and diameter of the pipe

5.2 (d)

Equivalent thermal resistance between two gray bodies exchanging heat

$$R_{th} = \frac{1 - \epsilon_1}{\epsilon_1 A_1} + \frac{1}{A_1 F_{12}} + \frac{1 - \epsilon_2}{\epsilon_2 A_2}$$

(i) For infinite parallel plates

$$F_{12} = 1$$

$$A_1 = A_2 = A$$

$$R_{th} = \frac{1}{A} \left[\frac{1}{\epsilon_1} - 1 + 1 + \frac{1}{\epsilon_2} - 1 \right]$$

$$= \frac{1}{A} \left[\frac{1}{\epsilon_1} + \frac{1}{\epsilon_2} - 1 \right]$$

(ii) Concentric cylinders

$$F_{12} = 1$$

$$R_{th} = \frac{1}{A_1} \left[\frac{1}{\epsilon_1} - 1 + 1 + \frac{A_1}{A_2} \left(\frac{1}{\epsilon_2} - 1 \right) \right]$$

$$= \frac{1}{A_1} \left[\frac{1}{\epsilon_1} + \frac{A_1}{A_2} \left(\frac{1}{\epsilon_2} - 1 \right) \right]$$

(iii) A small gray body (i) in a large gray enclosure (ii)

$$R_{th} = \frac{1 - \epsilon_1}{\epsilon_1 A_1} + \frac{1}{A_1 F_{12}} + \frac{1 - \epsilon_2}{\epsilon_2 A_2}$$

$$A_1 \ll A_2$$

$$\frac{A_1}{A_2} ; 0$$

and $F_{12} = 1$

$$R_{th} = \frac{1}{A_1} \left[\frac{1}{\epsilon_1} - 1 + 1 \right] = \frac{1}{\epsilon_1 A_1}$$

5.3 (c)

Radiosity is the rate at which energy is leaving from the surface (reflection and emission both). Gray surface is an imaginary surface which have emissivity independent of wavelength.

5.4 (c)

Black paints have less reflectivity. So suitable for radar system to detect airplanes.

5.5 (b)

From weins displacement law

$$\lambda_m T = \text{Constant}$$

if $T = 5800 \text{ K}$

$$\lambda_m = 0.5 \mu$$

$$C = 5800 \times 0.5 = 2900$$

Now $\lambda(300 + 273) = 2900$

$$\lambda = 5 \mu$$

5.6 (c)

$$A_1 F_{12} = A_2 F_{21}$$

$$F_{21} = \frac{A_1}{A_2} F_{12}$$

From geometry

$$F_{12} = 1$$

$$F_{21} + F_{22} = 1$$

$$F_{22} = 1 - F_{21}$$

$$F_{22} = 1 - \frac{A_1}{A_2} = 1 - \frac{\pi D_1 L}{\pi D_2 L}$$

$$F_{22} = 1 - \frac{1}{3} = \frac{2}{3}$$

5.7 (b)

$$q_1 = \sigma T^4$$

$$7.35 \times 10^3 = 5.67 \times 10^{-8} T^4$$

$$\left[\frac{7.35 \times 10^3}{5.67 \times 10^{-8}} \right]^{1/4} = T$$

$$T = 600 \text{ K} = 327^\circ\text{C}$$

5.8 (d)

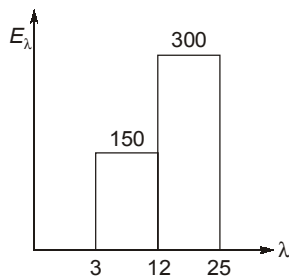

$$E = \int_0^\lambda E_\lambda \cdot dx$$

$$E = 150 \times (12 - 3) + 300 (25 - 12)$$

$$= 5250 \text{ W/m}^2$$

5.9 (a)

The emissivity of metallic surface is generally small. Therefore absorptivity will be low. Emissivity of nonconducting material is high so reflectivity low. For highly polished surface reflectivity is high.

5.10 (c)

More heat is lost by forced convection as the value of heat transfer coefficient is large. And while moving forced convection will occur.

5.11 (d)

Assertion is wrong.

5.12 (d)

$$q = \sigma T_1^4 = 5.67 \times 10^{-8} = 7348.2 \text{ W/m}^2$$

5.13 (a)

Stefan-Boltzman law : $Q = \sigma A (T_1^4 - T_2^4)$

Newton law of cooling : $Q = hA (T_1 - T_2)$

Fourier law : $Q = \frac{kA}{l} (T_1 - T_2)$

Kirchoff law : $E = \alpha E_b$

5.14 (d)

$$T_1 = 273 + 27 = 300 \text{ K}$$

$$T_2 = 627 + 273 = 900 \text{ K}$$

Emissive power = σT^4

$$= \frac{E_2}{E_1} = \left(\frac{T_2}{T_1} \right)^4 = \left(\frac{900}{300} \right)^4$$

$$\frac{E_2}{E_1} = 3^4 = 81$$

■■■■

6

Heat Exchangers

- 6.1** A counter flow shell and tube exchanger is used to heat water with hot exhaust gases. The water ($c_p = 4180 \text{ J/kg}^\circ\text{C}$) flows at the rate of 2 kg/s while the exhaust gas ($c_p = 1030 \text{ J/kg}^\circ\text{C}$) flows at the rate of 5.25 kg/s . If the heat transfer surface area is 32.2 m^2 and the overall heat transfer coefficient is $200 \text{ W/m}^2^\circ\text{C}$, the NTU for the heat exchanger is
- (a) 1.2 (b) 2.4
(c) 4.5 (d) 8.6

[ESE : 1995]

- 6.2** Match **List-I** with **List-II** and select answer using the codes given below the lists:

List-I

- A.** Regenerative heat exchanger
B. Direct contact heat exchanger
C. Conduction through a cylindrical wall
D. Conduction through a spherical wall

List-II

1. Water cooling tower
2. Ljungstrom air heater
3. Hyperbolic curve
4. Logarithmic curve

Codes:

	A	B	C	D
(a)	1	4	2	3
(b)	3	1	4	2
(c)	2	1	3	4
(d)	2	1	4	3

[ESE : 1995]

- 6.3** Heat pipe is widely used now a days because
- (a) it acts as an insulator
(b) it acts as conductor and insulator
(c) it acts as a superconductor
(d) it acts as a fin

[ESE : 1995]

- 6.4** A counter flow heat exchanger is used to heat water from 20°C to 80°C by using hot exhaust gas entering at 140°C and leaving at 80°C . The log

mean temperature difference for the heat exchanger is

- (a) 80°C
(b) 110°C
(c) 60°C
(d) Not determinable as zero is involved

[ESE : 1996]

- 6.5** A heat exchanger with heat transfer surface area A and overall heat transfer coefficient U handles two fluids of heat capacities C_1 and C_2 such that $C_1 > C_2$. The NTU of the heat exchanger is given by

- (a) $\frac{AU}{C_2}$ (b) $e^{-\left(\frac{AU}{C_2}\right)}$
(c) $e^{-\left(\frac{AU}{C_1}\right)}$ (d) $\frac{AU}{C_1}$

[ESE : 1996]

- 6.6** Consider the following statements:
The flow configuration in a heat exchanger, whether counter flow or otherwise, will not matter if
1. a liquid is evaporating.
 2. a vapour is condensing.
 3. mass flow rate of one of the fluids is far greater.

Which of these statements are correct?

- (a) 1 and 2 (b) 1 and 3
(c) 2 and 3 (d) 1, 2 and 3

[ESE : 1997]

- 6.7** Which one of the following diagrams correctly shows the temperature distribution for a gas-to-gas counter flow heat exchanger?

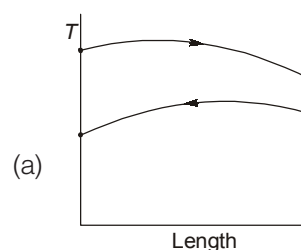

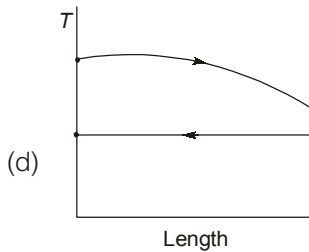
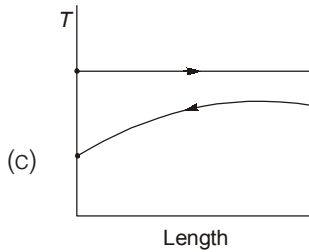
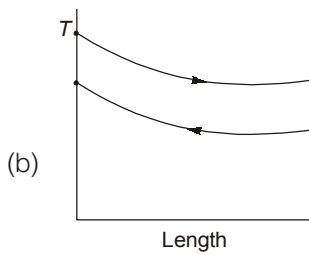

[ESE : 1997]

- 6.8 Consider the following statements :
The effect of fouling in a water-cooled steam condenser is that it
1. reduces the heat transfer coefficient of water.

2. reduces the overall heat coefficient.
3. reduces the area available for heat transfer.
4. increases the pressure drop of water.

Which of these statements are correct?

- (a) 1, 2 and 4 (b) 2, 3 and 4
(c) 2 and 4 (d) 1 and 3

[ESE : 1997]

6.9 **Assertion (A):** The *LMTD* for counter flow is larger than that of parallel flow for a given temperature of inlet and outlet.

Reason (R): The definition of *LMTD* is the same for both counter flow and parallel flow.

- (a) Both **A** and **R** are individually true and **R** is the correct explanation of **A**
(b) Both **A** and **R** are individually true but **R** is not the correct explanation of **A**
(c) **A** is true but **R** is false
(d) **A** is false but **R** is true

[ESE : 1998]

6.10 A cross-flow type air-heater has an area of 50 m². The overall heat transfer coefficient is 100 W/m²K and heat capacity of both hot and cold stream is 1000 W/K. The value of NTU is

- (a) 1000 (b) 500
(c) 5 (c) 0.2

[ESE : 1999]

■ ■ ■ ■

Answers Heat Exchangers

- 6.1 (a) 6.2 (d) 6.3 (c) 6.4 (c) 6.5 (a) 6.6 (d) 6.7 (b) 6.8 (a) 6.9 (b)
6.10 (c)

Explanations Heat Exchangers

6.1 (a)

$$c_w = \dot{m}_w c_{pw} = 2 \times 4180 = 8360 \text{ W/}^\circ\text{C}$$

$$c_g = \dot{m}_g c_{pg} = 5.25 \times 1030 = 5407.5 \text{ W/}^\circ\text{C}$$

Since $c_w > c_g$
hence $C_{\min} = 5407.5 \text{ W/}^\circ\text{C}$

$$NTU = \frac{UA}{C_{\min}} = \frac{200 \times 32.2}{5407.5} = 1.19 = 1.2$$

6.2 (d)

Temperature variation through a cylindrical wall is follow logarithmic profile and through sphere follow hyperbolic profile.

6.3 (c)

Heat pipe is device used to obtain very high rates of heat flow. In practice, the thermal conductance of heat pipe may be several hundred (500) times than that best available metal conductor, hence they act as super conductor.

6.4 (c)

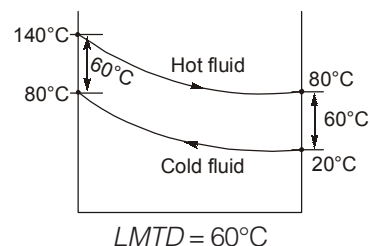

6.5 (a)

$$NTU = \frac{UA}{C_{\min}}$$

Since $C_2 < C_1$

$$NTU = \frac{UA}{C_2}$$

6.6 (d)

For condensation and evaporation capacity ratio $C = 0$.

$$C = \frac{C_{\min}}{C_{\max}} = 0$$

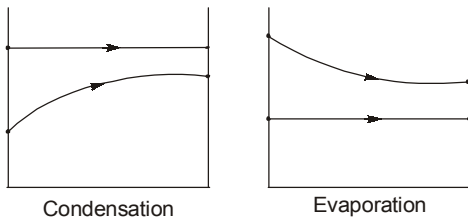

6.7 (b)

For counter flow heat exchanger.

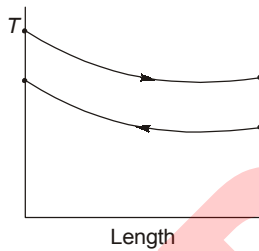

6.8 (a)

In a condenser cooling water from inside the tube and steam gets condensed on the surface. The fouling takes places inside the tube which leads to reduction in water side heat transfer coefficient and therefore reducing the overall heat transfer coefficient.

6.9 (b)

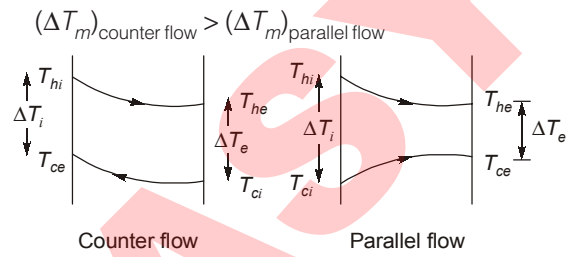

$$LMTD (\Delta T_m) = \frac{\Delta T_i - \Delta T_e}{\ln \left(\frac{\Delta T_i}{\Delta T_e} \right)}$$

For parallel flow

$$\Delta T_i = T_{hi} - T_{ci} \text{ and } \Delta T_e = T_{he} - T_{ce}$$

For counter flow

$$\Delta T_i = T_{hi} - T_{ce} \text{ and } \Delta T_e = T_{he} - T_{ci}$$

6.10 (c)

$$NTU = \frac{UA}{C_{\min}} = \frac{100 \times 50}{1000} = 5$$

■■■■

7.1 Consider the following statements regarding nucleate boiling:

1. The temperature of the surface is greater than the saturation temperature of the liquid.
2. Bubbles are created by the expansion of entrapped gas or vapour at small cavities in the surface.
3. The temperature is greater than that of film boiling.
4. The heat transfer from the surface to the liquid is greater than that in film boiling.

Which of these statements are correct?

- (a) 1, 2 and 4 (b) 1 and 3
(c) 1, 2 and 3 (d) 2, 3 and 4

[ESE : 1995]

7.2 **Assertion (A):** Even though dropwise condensation is more efficient, surface condensers are designed on the assumption of filmwise condensation as a matter of practice.

Reason (R): Dropwise condensation can be maintained with the use of promoters like oleic acid.

- (a) Both **A** and **R** are individually true and **R** is the correct explanation of **A**
(b) Both **A** and **R** are individually true but **R** is not the correct explanation of **A**
(c) **A** is true but **R** is false
(d) **A** is false but **R** is true

[ESE : 1995]

7.3 Consider the following statements regarding condensation heat transfer:

1. For a single tube, horizontal position is preferred over vertical position for better heat transfer.
2. Heat transfer coefficient decreases if the vapour stream moves at high velocity.
3. Condensation of steam on an oily surface is dropwise.

4. Condensation of pure benzene vapour is always dropwise.

Which of these statements are correct?

- (a) 1 and 2 (b) 1 and 3
(c) 2 and 4 (d) 3 and 4

[ESE : 1996]

7.4 The given figure shows a pool-boiling curve. Consider the following statements in this regard:

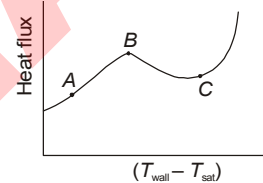

1. Onset of nucleation causes a marked change in slope.
2. At the point *B*, heat transfer coefficient is the maximum.
3. In an electrically heated wire submerged in the liquid, film heating is difficult to achieve.
4. Beyond the point *C*, radiation becomes significant.

Which of these statements are correct?

- (a) 1, 2 and 4 (b) 1, 3 and 4
(c) 2, 3 and 4 (d) 1, 2 and 3

[ESE : 1997]

7.5 Consider the following statements:

If a surface is marked with a number of cavities, then as compared to a smooth surface

1. radiation will increase.
2. nucleate boiling will increase.
3. conduction will increase.
4. convection will increase.

Which of these statements are correct?

- (a) 1, 2 and 3 (b) 1, 2 and 4
(c) 1, 3 and 4 (d) 2, 3 and 4

[ESE : 1997]

- 7.6 Hot coffee in a cup is allowed to cool. Its cooling rate is measured and found to be greater than the value calculated by conduction, convection and radiation measurement. The difference is due to
- properties of coffee changing with temperature
 - currents of air flow in the room
 - underestimation of the emissivity of coffee
 - evaporation

[ESE : 1997]

- 7.7 Consider the following phenomena:
- Boiling
 - Free convection in air
 - Forced convection
 - Conduction in air
- Their correct sequence in increasing order of heat transfer coefficient is:
- 4, 2, 3, 1
 - 4, 1, 3, 2
 - 4, 3, 2, 1
 - 3, 4, 1, 2

[ESE : 1997]

- 7.8 Consider the following statements:
- If a condensing liquid does not wet a surface then dropwise condensation will take place on it.

- Dropwise condensation gives a higher heat transfer rate than filmwise condensation.
- Reynolds number of condensing liquid is based on its mass flow rate.
- Suitable coating or vapour additive is used to promote filmwise condensation.

Which of these statements is/are correct?

- 1 and 2
- 2, 3, and 4
- 4 only
- 1, 2 and 3

[ESE : 1998]

- 7.9 Saturated steam is allowed to condense over a vertical flat surface and the condensate film flows down the surface. The local heat transfer coefficient for condensation
- remains constant at all locations of the surface
 - decreases with increasing distance from the top of the surface
 - increases with increasing thickness of condensate film
 - increases with decreasing temperature differential between the surface and vapour.

[ESE : 1999]

Answers Boiling and Condensation

7.1 (a) 7.2 (b) 7.3 (b) 7.4 (a) 7.5 (b) 7.6 (d) 7.7 (a) 7.8 (d) 7.9 (b)

Explanations Boiling and Condensation

7.1 (a)

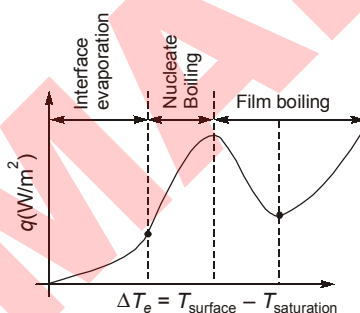

The nucleate boiling is characterised by formation of bubbles at the nucleation sites and resulting liquid agitation and from the figure, it can be estimated that temperature in nucleate boiling is less than film boiling. The nucleate boiling exists up to $\Delta T_e \simeq 30^\circ\text{C}$ while film boiling exist in the range of 30°C to 150°C .

7.2 (b)

Dropwise condensation is difficult to maintain during operation of device. So condenser design is always based on film condensation (heat transfer coefficient is smaller for film condensate).

7.3 (b)

Horizontal position promotes dropwise condensation and thickness of film formed is less. That is the reason condenser tubes are always kept horizontal.

Heat transfer coefficient will increase if velocity of vapour stream is increased as apart from latent heat exchange, the sensible heat exchange will be enhanced.

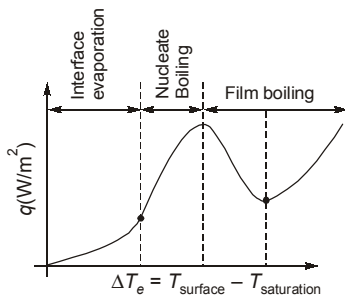
7.4 (a)**7.5 (b)**

Radiation will increase $Q \propto A$, surface convection will increase $Q \propto A$, surface nucleate boiling will increase as pocket will be the favourable sites for onset of nucleation.

7.6 (d)

Hot coffee in a cup is allowed to cool. While measuring its cooling rate evaporation is considered so its value is greater than the value calculated by conduction, convection and radiation.

7.7 (a)

$$h_{\text{boiling}} > h_{\text{forced convection}} > h_{\text{free convection}} > h_{\text{conduction}}$$

7.8 (d)

Dropwise condensation occurs on a non-wettable cooling surface where the liquid condensate drops do not spread. If the condensate tends to wet the surface and thereby forms a liquid film, then the condensation process is known as film condensation.

In film condensation, the heat is transferred from the vapour to the condensate formed on the surface by convection and it is further transferred from the condensate film to cooling surface by the conduction. This combined mode of heat transfer by conduction and convection reduces the rates of heat transfer considerably as compared to dropwise condensation.

Reynolds number of the condensate film, based on hydraulic diameter can be written as

$$Re = \frac{uD_p}{\mu} = U \left(\frac{4A}{\rho} \right) \frac{\rho}{\mu} = \frac{4\dot{m}}{\rho\mu}$$

Hence Reynolds number will depend on mass flow rate.

7.9 (b)

As the distance or thickness of condensate film increases the heat transfer decreases which is truly indicative of decrease in heat transfer coefficient. This is the reason we promote dropwise condensation.

■■■■

UNIT

IV

Internal Combustion Engines

Syllabus

SI and CI Engines, Engine Systems and Components, Performance characteristics and testing of IC Engines; Fuels; Emissions and Emission Control.

Contents

Sl.	Topic	Page No.
1.	Air Standard Cycle	85
2.	Fuel Characteristics	87
3.	Combustion and Knocking in SI and CI Engine	89
4.	Fuels and Emission, Flue Gas Analysis	94
5.	Testing and Performance of IC Engine	97

1

Air Standard Cycle

1.1 Which one of the following p - T diagrams illustrates the Otto cycle of an ideal gas?

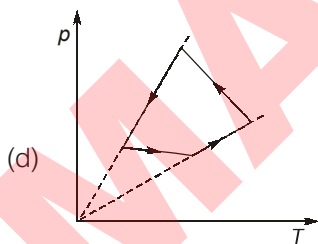
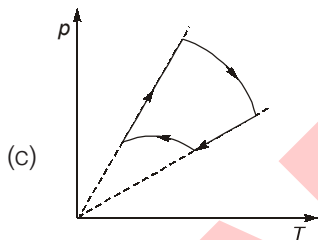
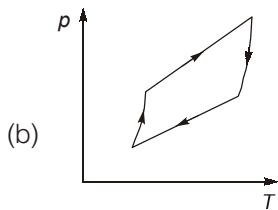
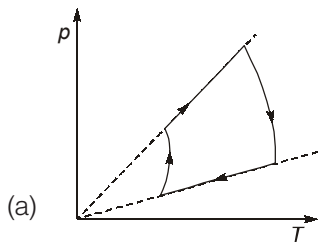

[ESE : 1996]

1.2 For maximum specific output of a constant volume cycle (Otto cycle)

- the working fluid should be air
- the speed should be high
- suction temperature should be high
- temperature of the working fluid at the end of compression and expansion should be equal

[ESE : 1997]

1.3 Match **List-I** (Details of process of the cycle) with **List-II** (Name of the cycle) and select correct answer using the codes given below the lists:

List-I

- Two isotherms and two adiabatics
- Two isotherms and two constant volumes
- Two adiabatics and two constant volumes
- Two adiabatics and two constant pressures

List-II

- Otto
- Joule
- Carnot
- Stirling

Codes:

	A	B	C	D
(a)	4	3	1	2
(b)	4	3	2	1
(c)	3	4	1	2
(d)	3	4	2	1

[ESE : 1997]

1.4 Consider the following statements regarding Otto cycle:

- It is not a reversible cycle.
- Its efficiency can be improved by using a working fluid of higher value of ratio of specific heats.
- The practical way of increasing its efficiency is to increase the compression ratio.
- Carburetted gasoline engines working on Otto cycle can work with compression ratios more than 12.

Which of these statements are correct?

- 1, 3 and 4
- 1, 2 and 3
- 1, 2 and 4
- 2, 3 and 4

[ESE : 1998]



Answers Air Standard Cycle

1.1 (a) 1.2 (d) 1.3 (c) 1.4 (b)

Explanations Air Standard Cycle**1.2 (d)**

Specific work = $c_v(T_3 - T_4) - c_v(T_2 - T_1)$
 For maximum work output

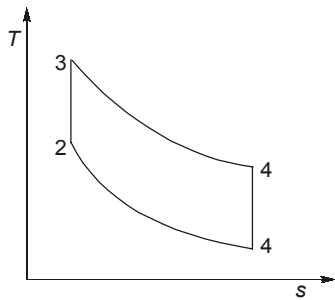

$$T_2 = T_4 = \sqrt{T_1 T_3}$$

$$W_{\max} = c_v [\sqrt{T_3} - \sqrt{T_1}]^2$$

1.3 (c)

- (1) Otto cycle : Two adiabatic and two constant volume
- (2) Joule cycle : Two adiabatic and two constant pressure.
- (3) Carnot cycle : Two adiabatic and two isothermal
- (4) Stirling cycle : Two isothermal and two constant volume

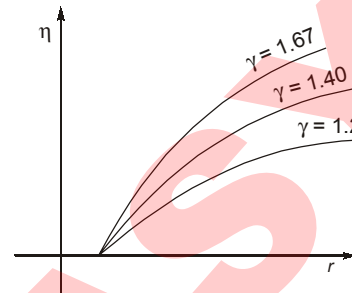
1.4 (b)

Otto cycle is reversible cycle

$$\eta = 1 - \frac{1}{r^{\gamma-1}} \quad r \uparrow, \eta \uparrow$$

If better fuel is available then we can employ Otto cycle for compression ratio more than 12.

■■■■

- 2.1 The two reference fuels used for cetane rating are
- cetane and iso-octane
 - cetane and tetraethyl lead
 - cetane and n-heptane
 - cetane and α -methyl naphthalene

[ESE : 1995]

- 2.2 Consider the following statements:
The injector nozzle of a CI engine is required to inject fuel at a sufficiently high pressure in order to
- be able to inject fuel in a chamber of high pressure at the end of the compression stroke.
 - inject fuel at high velocity to facilities atomization.
 - ensure that penetration is not high.

Which of these statements are correct?

- 1 and 2
- 1 and 3
- 2 and 3
- 1, 2 and 3

[ESE : 1996]

Direction: Each of the next questions consists of two statements, one labelled as the '**Assertion (A)**' and the other as '**Reason (R)**'. You are to examine these two statements carefully and select the answers to these items using the codes given below:

Codes:

- Both **A** and **R** are individually true and **R** is the correct explanation of **A**
- Both **A** and **R** are individually true but **R** is not the correct explanation of **A**
- A** is true but **R** is false
- A** is false but **R** is true

- 2.3 **Assertion (A):** In SI engine, as the engine speed increases, spark is required to be advanced.

Reason (R): As the engine speed increases, flame velocity increases.

[ESE : 1996]

- 2.4 Which one of the following figures correctly represents the variation of thermal efficiency (y-axis) with mixture strength (x-axis)?

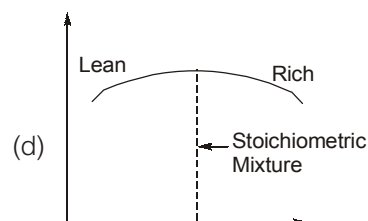
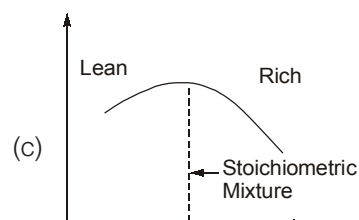
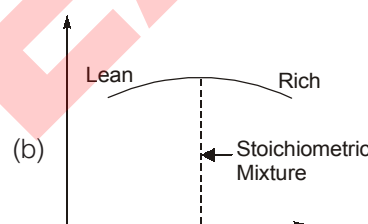
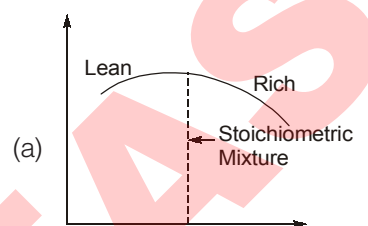

[ESE : 1997]



Answers Carburation and Diesel Injection

2.1 (d) 2.2 (b) 2.3 (b) 2.4 (c)

Explanations Carburation and Diesel Injection**2.1 (d)**

The cetane number of a fuel is the percentage by volume of cetane in a mixture of cetane and α -methyl naphthalene. (Cetane and α -methyl naphthalene are reference fuel in cetane number measurements.)

2.2 (b)

Fuel is injected at high pressure, not high velocity to facilitate atomization.

2.4 (c)

As the mixture is made leaner the temperature rise due to combustion will be lowered as a result of reduced energy input per unit mass of mixture. This will result in lower specific heat. Further it will lower the losses due to dissociation and variation in specific heat. The efficiency is therefore, higher.

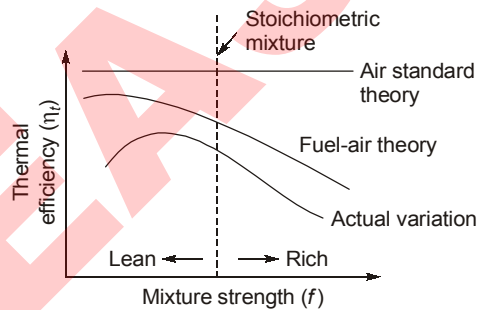

■■■■

3

Combustion and Knocking in SI and CI Engine

3.1 Match **List-I** (Operating mode of SI engine) with **List-II** (Appropriate Air-fuel Ratio) and select the correct answer using the codes given by below the lists:

List-I	List-II
A. Idling	1. 12.5
B. Cold starting	2. 9.0
C. Cruising	3. 16.0
D. Maximum power	4. 22.0
	5. 3.0

Codes:

	A	B	C	D
(a)	2	4	5	1
(b)	1	3	4	2
(c)	5	2	1	3
(d)	2	5	3	1

[ESE : 1995]

3.2 A gas engine has swept volume of 300 cc and clearance volume of 25 cc. Its volumetric efficiency is 0.88 and mechanical efficiency is 0.90. The volume of the mixture taken in per stroke is

- (a) 248 cc (b) 252 cc
(c) 264 cc (d) 286 cc [ESE : 1995]

3.3 Match **List-I** with **List-II**, in respect of SI engine and select the correct answer by using the codes given below the lists:

List-I
A. Highest useful compression ratio
B. Dopes
C. Limiting mixture strength
D. Delay period

List-II

1. Ignitable mixture
2. Knock rating of fuels
3. Detonation
4. Chain of chemical reactions in combustion chamber

Codes:

	A	B	C	D
(a)	2	3	1	4
(b)	3	2	1	4
(c)	2	3	4	1
(d)	3	4	2	1

[ESE : 1995]

3.4 By higher octane number of SI fuel, it is meant that the fuel has

- (a) higher heating value
- (b) higher flash point
- (c) lower volatility
- (d) Longer ignition delay

[ESE : 1995]

3.5 Which of the following factors would increase the probability of knock in the CI engines?

1. Long ignition delay of fuel.
2. Low self ignition temperature of fuel.
3. Low volatility of fuel.

Select the correct answer using the codes given below:

Codes:

- (a) 1, 2 and 3 (b) 1 and 2
(c) 1 and 3 (d) 2 and 3

[ESE : 1995]

3.6 The curve shown in the given figure is characteristic of diesel engines.

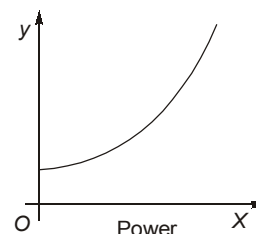

What does the Y-axis represent?

- (a) Efficiency
- (b) Specific fuel consumption
- (c) Air-fuel ratio
- (d) Total fuel consumption

[ESE : 1995]

- 3.7** Match **List-I** (SI engine operating mode) and **List-II** (Desired air-fuel ratio) and select the correct answer using the codes given below the lists:

List-I	List-II
A. Idling	1. 13.0
B. Cold starting	2. 4.0
C. Cruising	3. 16.0
D. Full throttle	4. 9.0

Codes:

	A	B	C	D
(a)	4	3	2	1
(b)	2	4	1	3
(c)	4	2	1	3
(d)	4	2	3	1

[ESE : 1996]

- 3.8** **List-I** gives the different terms related to combustion while **List-II** gives the outcome of the events that follow.

Match **List-I** with **List-II** and select the correct answer using the codes given below the lists:

List-I	List-II
A. Association	1. Pseudo knock
B. Dissociation	2. Knock
C. Flame front	3. Endothermic
D. Abnormal combustion	4. Exothermic

Codes:

	A	B	C	D
(a)	3	4	1	2
(b)	4	3	1	2
(c)	3	4	2	1
(d)	4	3	2	1

[ESE : 1996]

- 3.9** Consider the following statements:
Knock in the SI engine can be reduced by
1. Supercharging.
 2. Retarding the spark.
 3. Using a fuel of long straight chain structure.
 4. Increasing the engine speed.

Which of these statement are correct?

- (a) 1, and 2 (b) 2 and 3
(c) 1, 3 and 4 (d) 2 and 4

[ESE : 1996]

Direction: Each of the next questions consists of two statements, one labelled as the '**Assertion (A)**' and the other as '**Reason (R)**'. You are to examine these two statements carefully and select the answers to these items using the codes given below:

Codes:

- (a) Both **A** and **R** are individually true and **R** is the correct explanation of **A**
(b) Both **A** and **R** are individually true but **R** is not the correct explanation of **A**
(c) **A** is true but **R** is false
(d) **A** is false but **R** is true

- 3.10 Assertion (A):** A very high compression ratio is favoured for a CI engine, in order to attain high mechanical efficiency without knocking.

Reason (R): The delay period in CI combustion affects rate of pressure rise and hence knocking.

[ESE : 1996]

- 3.11 Assertion (A):** Pre-chamber diesel engines use higher injection pressures when compared to open combustion chamber engines.

Reason (R): Pre-chamber engines have higher compression pressures.

[ESE : 1997]

- 3.12** If methane undergoes combustion with the stoichiometric quantity of air, the air-fuel ratio on molar basis would be:

- (a) 15.22 : 1 (b) 12.30 : 1
(c) 14.56 : 1 (d) 9.52 : 1

[ESE : 1997]

- 3.13** Consider the following statements:

Detonation in the SI engine can be suppressed by

1. Retarding the spark timing.
2. Increasing the engine speed.
3. Using 10% rich mixture.

Which of these statements are correct?

- (a) 1 and 3 (b) 2 and 3
(c) 1, 2 and 3 (d) 1 and 2

[ESE : 1997]

- 3.14** Which of the following are the assumptions involved in the auto-ignition theory put forth for the onset of knock in SI engines?

1. Flame velocity is normal before the onset of autoignition.
2. A number of end-gas elements autoignite simultaneously.
3. Preflame reactions are responsible for preparing the end-gas to ignite.

Select the correct answer using the codes given below:

- (a) 1 and 2 (b) 1 and 3
(c) 2 and 3 (d) 1, 2 and 3

[ESE : 1998]

- 3.15 Hypothetical pressure diagram for a compression ignition engine is shown in the given figure. The diesel knock is generated during the period

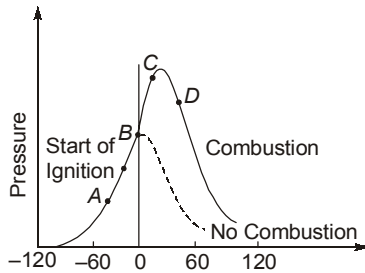

- (a) AB (b) BC
(c) CD (d) after D

[ESE : 1998]

- 3.16 Divided chamber diesel engines use lower injection pressures compared to open chamber engines because
- Pintle nozzles cannot withstand high injection pressures
 - High air swirl does not require high injection pressures for atomization
 - High injection pressures may cause over-penetration

- (d) High injection pressure causes leakage of the fuel at the pintle [ESE : 1999]

- 3.17 Velocity of flame propagation in the SI engine is maximum for a fuel-air mixture which is
- 10% richer than stoichiometric
 - Equal to stoichiometric
 - More than 10% richer than stoichiometric
 - 10% leaner than stoichiometric

[ESE : 1999]

- 3.18 The amount of CO_2 produced by 1 kg of carbon on complete combustion is

- (a) $\frac{3}{11}$ kg (b) $\frac{3}{8}$ kg
(c) $\frac{8}{3}$ kg (d) $\frac{11}{3}$ kg [ESE : 1999]

- 3.19 Methane burns with stoichiometric quantity of air. The air-fuel ratio by weight is

- (a) 4 (b) 14.7
(c) 15 (d) 17.16 [ESE : 1999]

■■■■

Answers Combustion and Knocking in SI and CI Engine

- 3.1 (d) 3.2 (c) 3.3 (a) 3.4 (d) 3.5 (c) 3.6 (d) 3.7 (d) 3.8 (b) 3.9 (d)
3.10 (b) 3.11 (d) 3.12 (d) 3.13 (c) 3.14 (d) 3.15 (b) 3.16 (b) 3.17 (a) 3.18 (d)
3.19 (d)

Explanations Combustion and Knocking in SI and CI Engine

3.1 (d)

Cold starting requires the richest rich air fuel ratio than other requirement because the speed as well as engine temperature is low and hence in cold starting air fuel ratio of 3 : 1 is used.

In **Idling condition**, the air supply is restricted by nearly closed throttle and suction pressure is low. The condition of low pressure lines gives rise to backflow of exhaust gases so dilution of fresh charge takes place hence richening of mixture is done. Hence in idling air fuel ratio of 9 is used. In cruising economy is the criteria so lean mixture is used.

For maximum power rich mixture is provided to meet the power requirement and also rich mixture

prevents overheating of the exhaust valve.

3.2 (c)

$$\eta_v = \frac{\text{Actual volume of air sucked}}{\text{Theoretical volume of air sucked}}$$

$$0.88 = \frac{V_{\text{actual}}}{300}; \quad V_{\text{actual}} = 264 \text{ cc}$$

3.3 (a)

Highest Useful Compression Ratio (HUCR) for SI engine fuel is limited to knocking tendency of fuel as it is used as one of the methods for knock rating of fuel.

Dopes are chemical additive which are used to improve combustion performance of fuel.

Limiting mixture strength is the range for ignitable mixture. The ignition limits are wider at increased temperature because of higher rates of reaction and high thermal diffusivity coefficient of mixture.

Delay period is related with detonation in CI engine. Higher the delay period more is the tendency of knocking in CI engine.

3.4 (d)

Higher Octane is related only to longer ignition delay which prevent knocking. High Octane fuel itself don't increases power or enhances other property of fuel.

3.5 (c)

In CI engine long ignition delay leads to knocking.

3.6 (d)

Graph shown is for Willan's line method

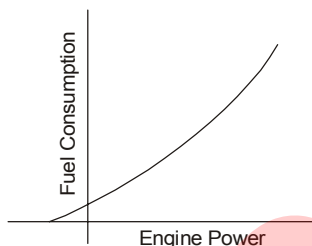

This graph is extrapolated to get Friction power.

3.7 (d)

Cold starting requires the richest rich air fuel ratio than other requirement because the speed as well as engine temperature is low and hence in cold starting air fuel ratio of 3 : 1 is used.

In **Idling** condition, the air supply is restricted by nearly closed throttle and suction pressure is low. The condition of low pressure lines gives rise to backflow of exhaust gases so dilution of fresh charge takes place hence richening of mixture is done. Hence in idling air fuel ratio of 12.5 is used. In **cruising** economy is the criteria so lean mixture is used.

For **maximum power** rich mixture is provided to meet the power requirement and also rich mixture prevents overheating of the exhaust valve.

3.8 (b)

Abnormal combustion leads to knock. In association heat is liberated hence it is exothermic reaction and in dissociation, heat is absorbed hence it is endothermic reaction.

3.9 (d)

Supercharging increases the knocking tendency as temperature of charge increased beyond ignition temperature. Long chain fuel structure have high tendency to knock in SI engine. Increase in engine speed increases flame travel speed so knocking reduces and retarding of spark also reduces knocking.

3.10 (b)

CI engine operate at compression ratio which are considerably higher than those used by SI engines. High compression ratios of CI engines are necessary in order to compress the air to the point producing a temperature necessary to promote satisfactory combustion. This air temperature of course, must be higher than the ignition temperature of the fuel used. An increase in compression ratio increases the thermal efficiency of the engine, and for given compression ratio the CI engine cycle is less efficient than the SI engine cycle.

3.11 (d)

The rate of pressure rise and the maximum pressure is lower in pre combustion chamber compared to those of open type of chamber.

3.12 (d)

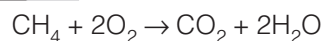

$$2 \text{ Volume of O}_2 \text{ is present in } \frac{100 \times 2}{21}$$

$$= 9.352 \text{ by Volume of air}$$

3.13 (c)

When spark is advanced the burning gas is compressed by rising piston and therefore the temperature is increased and this increases the knocking tendency. Hence spark must be retarded to reduce knocking.

Increase in engine speed, increases turbulence and hence flame velocity increases. Therefore knocking tendency decreases.

When the mixture is nearly 10% richer than stoichiometric then flame speed is maximum hence end charge is consumed before its delay period.

3.16 (b)

Divided combustion chamber has strong swirl generated with speed. The strong swirl enable single hole nozzle generally pintle type.

3.17 (a)

Velocity of flame propagation is maximum when mixture strength is 110% of stoichiometric.

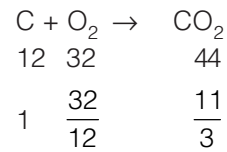
3.18 (d)

12 kg carbon reacts with 32 kg to give 44kg of CO₂. Hence 1 kg of Carbon produces 11/3 kg of CO₂.

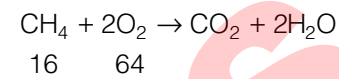
3.19 (d)

A/F ratio by weight is $\frac{64}{16} \times \frac{100}{23} = 17.39$

■■■■

4

Fuels and Emission, Flue Gas Analysis

4.1 In the Orsat flue gas analyzer, ammoniacal cuprous chloride is used to absorb
 (a) CO_2 (b) CO
 (c) O_2 (d) N_2 [ESE : 1995]

4.2 Dry flue gases with a composition of $\text{CO}_2 = 10.4\%$, $\text{O}_2 = 9.6\%$ and $\text{N}_2 = 80\%$, indicate that
 (a) excess air is used
 (b) air is insufficient
 (c) hydrogen is not present in the coal
 (d) air is just sufficient [ESE : 1995]

4.3 Consider the following statements regarding n-cetane:
 1. It is standard fuel used for knock rating of diesel engines.
 2. Its chemical name is n-hexadecane.
 3. It is a saturated hydrocarbon of paraffin series.
 4. It has long carbon chain structure.
 Which of these statements are correct?
 (a) 1, 3 and 4 (b) 1, 2 and 3
 (c) 1, 2 and 4 (d) 2, 3 and 4 [ESE : 1996]

4.4 Which of the following factors are responsible for formation of No_x in spark ignition engine combustion:
 1. Incomplete combustion
 2. High temperature
 3. Availability of oxygen
 (a) 2 and 3 (b) 1 and 2
 (c) 1 and 3 (d) 1, 2 and 3 [ESE : 1996]

4.5 Match List-I (Items) with List-II (Pertain to gas analysis) and select the correct answer using the codes given below the lists:

List-I

- A. CO_2
- B. Orsat apparatus
- C. CO
- D. O_2

List-II

- 1. Alkaline pyrogallol
- 2. KOH solution
- 3. Wet analysis
- 4. Ammoniacal cuprous chloride
- 5. Dry analysis

Codes:

	A	B	C	D
(a)	2	3	1	4
(b)	1	3	2	4
(c)	1	5	4	2
(d)	2	5	4	1

[ESE : 1996]

4.6 When solid fuels are burned, the nitrogen content of the flue gas by volume is about
 (a) 60% (b) 70%
 (c) 80% (d) 90% [ESE : 1996]

4.7 In a SI engine, which one of the following is the correct order of the fuels with increasing detonation tendency?
 (a) Paraffins, Olefins, Naphthalenes, Aromatics
 (b) Aromatics, Naphthalenes, Paraffins, Olefins
 (c) Naphthalenes, Olefins, Aromatics, Paraffins
 (d) Aromatics, Naphthalenes, Olefins, Paraffins [ESE : 1997]

4.8 The presence of nitrogen in the products of combustion ensures that :
 (a) complete combustion of fuel takes place
 (b) incomplete combustion of fuel occurs
 (c) dry products of combustion are analyzed
 (d) air is used for the combustion [ESE : 1997]

4.9 The graph shown in the given figure represents the emission of a pollutant from an SI engine for different fuel/air ratios. The pollutant in question is

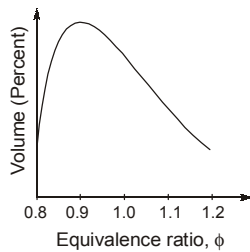

- (a) CO (b) CO₂
 (c) HC (d) NO_x

[ESE : 1998]

4.10 Consider the following statements

The difference between higher and lower heating values of the fuels is due to

- Heat carried by steam from the moisture content of fuel.
- Sensible heat carried away by the fuel gases.
- Heat carried away by steam from the combustion of hydrogen in the fuel.
- Heat lost by radiation.

Which of these statements is/are correct?

- (a) 2, 3 and 4 (b) 1 and 2
 (c) 3 only (d) 1, 2, 3 and 4

[ESE : 1998]

4.11 Match **List-I** (Gadgets undergoing a thermodynamic process) with **List-II** (Property of the system that remains constant) and select the correct answer using the codes given below the lists:

List-I

- A.** Bomb calorimeter
B. Exhaust gas calorimeter
C. Junker gas calorimeter
D. Throttling calorimeter

List-II

- Pressure
- Enthalpy
- Volume
- Specific heats

Codes:

	A	B	C	D
(a)	3	4	1	2
(b)	2	4	1	3
(c)	3	1	4	2
(d)	4	3	2	1

[ESE : 1998]

4.12 Consider the following emission of an IC Engine:

- (1) CO (2) HC
 (3) NO_x (4) Particulates

Which of the following causes photo chemical smog?

- (a) 1, 2 and 3 (b) 1 and 2
 (c) 2 and 3 (d) 3 and 4

[ESE : 1999]

4.13 Assertion (A): In a three-way catalytic converter for emission control in SI Engines, conversion of NO_x has to precede the oxidation of HC and CO.

Reason (R): A reducing atmosphere is essential for the conversion of NO_x.

- (a) Both **A** and **R** are individually true and **R** is the correct explanation of **A**
 (b) Both **A** and **R** are individually true but **R** is not the correct explanation of **A**
 (c) **A** is true but **R** is false
 (d) **A** is false but **R** is true

[ESE : 1999]

4.14 Which one of the following gaseous fuels does not have different higher and lower calorific values?

- (a) Methane (b) Ethane
 (c) Carbon monoxide (d) Hydrogen

[ESE : 1999]

■■■■

Answers Fuels and Emission, Flue Gas Analysis

- 4.1** (b) **4.2** (a) **4.3** (b) **4.4** (a) **4.5** (d) **4.6** (c) **4.7** (d) **4.8** (d) **4.9** (d)
4.10 (c) **4.11** (a) **4.12** (c) **4.13** (b) **4.14** (c)

Explanations Fuels and Emission, Flue Gas Analysis**4.1 (b)**

The reagents normally used in orsat analyzer are a KOH solution to absorb the CO_2 gas, pyrogallol solution to absorb the O_2 gas and a cuprous chloride mixture (CuCl_2) to absorb CO gas.

4.2 (a)

Presence of CO_2 in the flue gases shows that combustion is complete and if excess air is used some amount of air will not take part in combustion and come-out as it is.

4.3 (b)

Chemical formula of cetane is $\text{C}_{16}\text{H}_{34}$. It is also known as hexadecane. It follows $\text{C}_n\text{H}_{2n+2}$ which is a saturated hydrocarbon of paraffin series. It is used as a standard fuel for knock rating of diesel engine fuel.

4.5 (d)

The reagents normally used in orsat analyzer are a KOH solution to absorb the CO_2 gas, pyrogallol solution to absorb the O_2 gas and a cuprous chloride mixture (CuCl_2) to absorb CO gas.

Orsat apparatus is used for volumetric analysis of dry product.

4.6 (c)

Let us consider a coal having the following ultimate analysis:

$$\text{C} = 60\%$$

$$\text{H} = 4\%$$

$$\text{S} = 3.2\%, \text{O} = 4.8\%, \text{N} = 2\%$$

$$\text{Others} = 26\%$$

Then the exhaust gas has the following volumetric analysis:

$$\text{CO}_2 + \text{SO}_2 = 12\%$$

$$\text{CO} = 2\%$$

$$\text{O}_2 = 4\%$$

$$\text{N}_2 = 82\%$$

4.7 (d)

Clustered structure do not oxidize easily so do not knock readily. Hydrocarbon of extended chain oxidise readily so knock tendency more.

4.8 (d)

Nitrogen does not take part in combustion and comes out as it is hence nitrogen in the exhaust shows air is used for combustion.

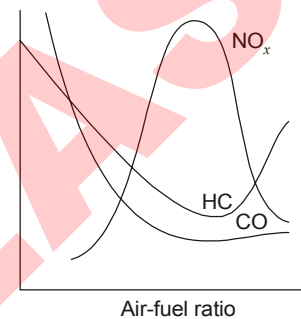
4.9 (d)**4.10 (c)**

Difference in the higher and lower calorific value is the latent heat of the moisture not the sensible heat.

4.11 (a)

Throttling calorimeter: It utilizes the principle of constant enthalpy expansion for the measurement of moisture content of steam.

Exhaust gas calorimeter: It determines heat content of exhaust gas.

4.12 (c)

The combination of HC and NO_x in the presence of sunlight and certain atmospheric conditions produce photochemical smog.

■■■■

5

Testing and Performance of IC Engine

- 5.1** Keeping other parameters constant, the brake power of diesel engine can be increased by
- decreasing the density of intake air
 - increasing the temperature of intake air
 - increasing the pressure of intake air
 - decreasing the pressure of intake air

[ESE : 1995]

- 5.2** The method of determination of indicated power of multicylinder SI engine is by the use of
- Morse test
 - Prony brake test
 - Motoring test
 - Heat balance test

[ESE : 1995]

- 5.3** The correct sequence of the decreasing order of brake thermal efficiency of the three given basic type of IC Engines is

- 4 stroke CI engine, 4 stroke SI engine, 2 stroke SI engine
- 4 stroke SI engine, 4 stroke CI engine, 2 stroke SI engine
- 4 stroke CI engine, 4 stroke SI engine, 4 stroke SI engine
- 2 stroke SI engine, 2 stroke SI engine, 4 stroke CI engine

[ESE : 1995]

- 5.4** Which one of the following engines will have heavier flywheel than the remaining ones?

- 40 H.P. four-stroke petrol engine running at 1500 rpm.
- 40 H.P. two-stroke petrol engine running at 1500 rpm.
- 40 H.P. two-stroke diesel engine running at 750 rpm
- 40 H.P. four-stroke diesel engine running at 750 rpm

[ESE : 1996]

- 5.5** In the context of performance evaluation of IC Engine, match **List-I** (Parameter) with **List-II** (Equipment for measurement) and select the correct answer using the codes below the lists:

List-I

- Brake power (B.H.P.)
- Engine speed
- Calorific value of fuel
- Exhaust emissions

List-II

- Bomb calorimeter
- Electrical tachometer
- Hydraulic dynamometer
- Flame ionization detector

Codes:

	A	B	C	D
(a)	3	1	2	4
(b)	4	2	1	3
(c)	3	2	1	4
(d)	2	3	4	1

[ESE : 1996]

- 5.6** A two-stroke engine has a speed of 750 rpm. A four-stroke engine having an identical cylinder size runs at 1500 rpm. The theoretical output of the two-stroke engine will

- be twice that of the four-stroke engine
- be half that of the four-stroke engine
- be the same as that of the four-stroke engine
- depend upon whether it is a CI or SI engine

[ESE : 1997]

- 5.7** For same power output and same compression ratio, as compared to two-stroke engines, four-stroke SI engine have:

- higher fuel consumption
- lower thermal efficiency
- higher exhaust temperatures
- Higher thermal efficiency

[ESE : 1997]

5.8 Match **List-I** (Performance parameters of an IC Engine) with **List-II** (Performance curves) and select the correct answer using the codes given below the lists:

List-I

- A. Indicated power
- B. Volumetric efficiency
- C. Brake power
- D. Specific fuel consumption

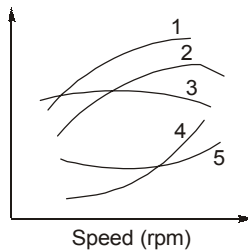
List-II**Codes:**

- | | A | B | C | D |
|-----|---|---|---|---|
| (a) | 1 | 3 | 2 | 5 |
| (b) | 1 | 3 | 2 | 4 |
| (c) | 1 | 2 | 3 | 5 |
| (d) | 2 | 1 | 4 | 3 |

[ESE : 1997]

5.9 Consider the following statements:

1. Volumetric efficiency of diesel engines is higher than that of SI engines.
2. When a SI engine is throttled; its mechanical efficiency decreases.
3. Specific fuel consumption increases as the power capacity of the engine increases.
4. In spite of higher compression ratios, the exhaust temperature in diesel engines is much lower than that SI engines.

Which of these statements are correct?

- (a) 1, 2, 3 and 4
- (b) 1, 2 and 3
- (c) 3 and 4
- (d) 1, 2 and 4

[ESE : 1997]

Direction: Each of the next questions consists of two statements, one labelled as the '**Assertion (A)**' and the other as '**Reason (R)**'. You are to examine these two statements carefully and select the answers to these items using the codes given below:

Codes:

- (a) Both **A** and **R** are individually true and **R** is the correct explanation of **A**
- (b) Both **A** and **R** are individually true but **R** is not the correct explanation of **A**
- (c) **A** is true but **R** is false
- (d) **A** is false but **R** is true

5.10 **Assertion (A):** In practice, the efficiency of diesel engines is higher than that of petrol engines.

Reason (R): For the same compression ratio, the efficiency of diesel cycle is higher than that of Otto cycle.

[ESE : 1997]

5.11 **Assertion (A):** Specific output of a diesel engine is higher than that of the SI engine.

Reason (R): Diesel engine is built stronger and heavier with higher compression ratio.

[ESE : 1998]

5.12 **Assertion (A):** Cooling system in a IC Engine must be such that there is no excessive cooling.

Reason (R): Overcooling would result in increased viscosity of the lubricant due to which the overall efficiency of the engine will decrease.

[ESE : 1998]

5.13 In a variable speed SI Engine, the maximum torque occurs at the maximum

- (a) Speed
- (b) Brake power
- (c) Indicated power
- (d) Volumetric efficiency

[ESE : 1999]

5.14 In a Morse test for a 2-cylinder, 2-stroke, spark ignition engine, the brake power was 9 kW whereas the brake power of individual cylinders with spark cut-off were 4.25 kW and 3.75 kW respectively. The mechanical efficiency of the engine is

- (a) 90%
- (b) 80%
- (c) 45.5%
- (d) 52.5%

[ESE : 1999]

■■■■

Answers Testing and Performance of IC Engine

- 5.1 (c) 5.2 (a) 5.3 (a) 5.4 (d) 5.5 (c) 5.6 (c) 5.7 (d) 5.8 (a) 5.9 (d)
5.10 (c) 5.11 (d) 5.12 (a) 5.13 (b) 5.14 (a)

Explanations Testing and Performance of IC Engine**5.1 (c)**

Brake power of diesel engine can be increased by supplying air at higher pressure, this pressure boosting device is known as supercharger.

5.2 (a)

Morse test is used for determining indicated power of multi-cylinder engine from which frictional power can be calculated.

5.4 (d)

In two stroke engines, turning moment is more uniform as compared to four stroke engine hence lighter flywheel is required in two stroke as compared is four stroke engine.

5.6 (c)

$$IP = \frac{P_m LAN}{60}$$

For 2 stroke: $n = N = 750$ rpm

For 4 stroke: $n = N/2 = \frac{1500}{2} = 750$ rpm

$$\therefore IP_1 = IP_2$$

5.7 (d)

High fuel consumption, low thermal efficiency and high exhaust temperatures will be associated with two stroke engine.

four stroke engine will have high thermal efficiency because mass flow rate of fuel required will be less as comparison to two stroke engine for same power.

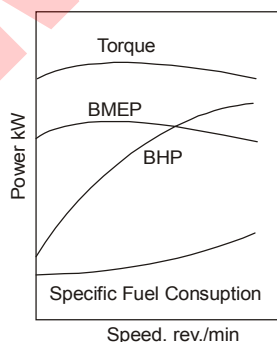
5.8 (a)**5.9 (d)**

$$BSFC = \frac{\dot{m}_f}{B.P.}$$

As the power capacity increases, specific fuel consumption decreases.

The thermal efficiency of the CI engine is higher than that of the SI engine because of the higher compression ratio. The losses to the exhaust are therefore lower resulting in lower exhaust temperatures.

The excess air in the CI engine further reduces the exhaust temperatures.

5.10 (c)

For same compression ratio otto cycle is more efficient and produces more work than diesel cycle.

5.11 (d)

Because of higher compression ratio and the higher pressure involved, CI engines require stronger engine and are inherently heavier.

5.13 (b)

$$\text{Brake power} = \frac{2\pi NT}{60}$$

where, N = Speed in rpm; T = Torque

5.14 (a)

$$(IP)_n = (BP)_n + FP$$

$$(IP)_{n-1} = (BP)_{n-1} + FP$$

$$(IP)_{1st} = (BP)_{n_{cylinder}} - (BP)_{n-1} \\ = 9 - 4.25 = 4.75 \text{ kW}$$

$$(IP)_{2nd} = 9 - 3.75 = 5.25 \text{ kW}$$

$$\text{Total } IP = 4.75 + 5.25 = 10 \text{ kW}$$

$$\therefore \eta_m = \frac{BP}{IP} = \frac{9}{10} \times 100 = 90\%$$

■■■■

UNIT

V

Refrigeration and Air-conditioning

Syllabus

Vapour compression refrigeration, Refrigerants and Working cycles, Condensers, Evaporators and Expansion devices, Other types of refrigeration systems like Vapour absorption, Vapour jet, Thermo electric and Vortex tube refrigeration. Psychrometric properties and processes, Comfort chart, Comfort and industrial air conditioning, Load calculations and Heat pumps.

Contents

Sl.	Topic	Page No.
1.	Heat Pump and Refrigeration Systems	101
2.	Ideal, Vapour, Air Refrigeration Cycle and Refrigerants	103
3.	Refrigeration Equipments	110
4.	Psychrometry and Psychrometric Processes	112
5.	Cooling Load Calculations and Duct Design	116

○○○○

1

Heat Pump and Refrigeration Systems

- 1.1 A condenser of a refrigeration system rejects heat at rate of 120 kW, while its compressor consumes a power of 30 kW. The coefficient of performance of the system would be
(a) 1/4 (b) 1/3
(c) 3 (d) 4 [ESE : 1995]
- 1.2 In aircraft, air refrigeration cycle is used because of
(a) low unit weight per tonne of refrigeration
(b) high heat transfer rate
(c) lower temperature at high-altitudes
(d) higher coefficient of performance [ESE : 1995]
- 1.3 **Assertion (A):** Heat pump used for heating is a definite advancement over the simple electric heater.
Reason (R): The heat pump is far more economical in operation than electric heater.
(a) Both **A** and **R** are individually true and **R** is the correct explanation of **A**
(b) Both **A** and **R** are individually true but **R** is not the correct explanation of **A**
(c) **A** is true but **R** is false
(d) **A** is false but **R** is true [ESE : 1995]
- 1.4 Hydrogen is essential in an Electrolux refrigeration system, because
(a) it acts as a catalyst in the evaporator
(b) the reaction between hydrogen and ammonia is endothermic in evaporator and exothermic in absorber
(c) the cooled hydrogen leaving the heat exchanger cools the refrigerant entering the evaporator
(d) it helps in maintaining a low partial pressure for the evaporating ammonia [ESE : 1997]
- 1.5 Consider the following statements:
In the thermoelectric refrigeration, the coefficient of performance is a function of:
1. Electrical conductivity of materials.
2. Peltier coefficient.
3. Seebeck coefficient.
4. Temperature at cold and hot junctions.
5. Thermal conductivity of materials.
Which of these statements are correct?
(a) 1, 3, 4 and 5 (b) 1, 2, 3 and 5
(c) 1, 2, 4 and 5 (d) 2, 3, 4 and 5 [ESE : 1997]
- 1.6 A refrigerating machine working on reversed Carnot cycle takes out 2 kW per minute of heat from the system while between temperature limits of 300 K and 200 K. COP and power consumed by the cycle will be respectively:
(a) 1 and 1 kW (b) 1 and 2 kW
(c) 2 and 1 kW (d) 2 and 2 kW [ESE : 1997]
- 1.7 A heat pump operating on Carnot cycle pumps heat from a reservoir at 300 K to a reservoir at 600 K. The coefficient of performance is
(a) 1.5 (b) 0.5
(c) 2 (d) 1 [ESE : 1999]
- 1.8 One ton refrigeration is equivalent to
(a) 3.5 kW (b) 50 kJ/s
(c) 1000 J/min (d) 1000 kJ/min [ESE : 1999]

Answers Heat Pump and Refrigeration Systems

- 1.1 (c) 1.2 (a) 1.3 (a) 1.4 (d) 1.5 (c) 1.6 (c) 1.7 (c) 1.8 (a)

Explanations Heat Pump and Refrigeration Systems**1.1 (c)**

Given data :

$$Q_1 = 120 \text{ kW}$$

$$W = 30 \text{ kW}$$

also $W = Q_1 - Q_2$

$$\therefore 30 = 120 - Q_2$$

or $Q_2 = 120 - 30 = 90 \text{ kW}$

$$(COP)_R = \frac{\text{Cooling capacity } (Q_2)}{\text{Power input } (P)} = \frac{90}{30} = 3$$

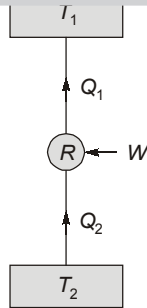
**1.2 (a)**

In aircraft, air refrigeration cycle is used because of low unit weight per tonne of refrigeration.

1.3 (a)

At steady state, the electrical energy W supplied to an electrical heater is dissipated as heat to the space but when supplied to a heat pump dissipates Q_1 which is greater than W .

1.4 (d)

The three fluids used in this system are ammonia, hydrogen and water. The ammonia is used as a refrigerant.

The water is used as a solvent because it has the ability to absorb ammonia readily.

Due to the presence of H_2 in the low side of the system, the pressure of NH_3 will be below that of NH_3 on the condenser side. Thus, the NH_3 can evaporate at low pressure (temperature) which H_2 takes no part in the process except to supply its partial pressure to maintain the balance.

1.6 (c)

Given data:

$$Q_2 = 2 \text{ kW}$$

$$T_1 = 300 \text{ K}$$

$$T_2 = 200 \text{ K}$$

$$\begin{aligned} COP &= \frac{T_2}{T_1 - T_2} \\ &= \frac{200}{300 - 200} = 2 \end{aligned}$$

also $COP = \frac{Q_2}{W}$

$$\therefore 2 = \frac{2}{W}$$

or $W = \frac{2}{2} = 1 \text{ kW per minute}$

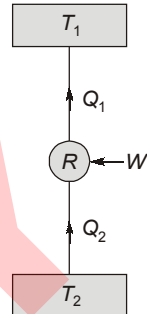
**1.7 (c)**

Given data:

$$T_2 = 300 \text{ K}$$

$$T_1 = 600 \text{ K}$$

$$\begin{aligned} (COP)_{HP} &= \frac{T_1}{T_1 - T_2} \\ &= \frac{600}{600 - 300} = 2 \end{aligned}$$

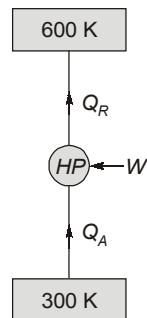
**1.8 (a)**

A ton of refrigeration (1 TR) is defined as the amount of heat, which is to be extracted from one tonne of water at 0°C in order to convert into ice at 0°C in 24 hours (1 day).

$$1 \text{ TR} = 210 \text{ kJ/min} = 3.5 \text{ kW}$$



2

Ideal, Vapour, Air Refrigeration Cycle and Refrigerants

2.1 Waste heat can be effectively used in which one of the following refrigeration system?

- Vapour compression cycle
- Vapour absorption cycle
- Air refrigeration cycle
- Vortex refrigeration system

[ESE : 1995]

2.2 Match **List-I** (Refrigerant) with **List-II** (Principal application) and select the correct answer using the codes given below the lists:

List-I

- Air
- Ammonia
- Carbon dioxide
- R-11

List-II

- Direct contact freezing of food
- Centrifugal compressor system
- Large industrial temperature installation
- Automotive air-conditioners
- Aircraft refrigeration

Codes:

	A	B	C	D
(a)	3	4	1	2
(b)	5	3	1	2
(c)	2	4	3	5
(d)	5	3	2	1

[ESE : 1995]

2.3 Match **List-I** (Basic components of Aqua ammonia refrigeration system) with **List-II** (Functions of the components in the system) and select the correct answer using the code given below the lists:

List-I

- Generator
- Analyzers
- Rectifier
- Receiver

List-II

- Dehydration
- Removal of vapour from strong aqua ammonia solution
- Producing dry ammonia vapour by removing traces of water particles completely
- Storage of high pressure liquid ammonia
- Formation of liquid ammonia from high pressure vapours

Codes:

	A	B	C	D
(a)	3	1	2	5
(b)	5	3	4	2
(c)	1	3	2	5
(d)	2	1	3	4

[ESE : 1995]

2.4 Consider the following statements :

A decrease in evaporator temperature of a vapour compression machine leads to

- an increase in refrigerating effect.
- an increase in specific volume of vapour.
- a decrease in volumetric efficiency of compressor.
- an increase in compressor work.

Which of these statements are correct?

- 1, 3 and 4
- 1, 2 and 3
- 2, 3 and 4
- 2 and 4

[ESE : 1995]

2.5 **Assertion (A):** In vapour compression refrigeration system throttle valve is used and not expansion cylinder.

Reason (R): Throttling is a constant enthalpy process.

- Both **A** and **R** are individually true and **R** is the correct explanation of **A**
- Both **A** and **R** are individually true but **R** is not the correct explanation of **A**
- A** is true but **R** is false
- A** is false but **R** is true

[ESE : 1995]

2.6 Consider the following statements:

1. Practically all common refrigerants have approximately the same COP and power requirement.
2. Ammonia mixes freely with lubricating oil and this helps lubrication of compressors.
3. Dielectric strength of refrigerants is an important property in hermetically sealed compressor units.
4. Leakage of ammonia can be detected by halide torch method.

Which of these statements are correct?

- (a) 1, 2 and 4 (b) 2 and 4
(c) 1, 3 and 4 (d) 1 and 3

[ESE : 1996]

2.7 In a vapour compression refrigeration system, throttle valve is used in place of an expander because

- (a) it considerably reduces the system weight
- (b) it improves the COP, as the condenser is small
- (c) the positive work in isentropic expansion of liquid is very small
- (d) it leads to significant cost reduction

[ESE : 1996]

2.8 The refrigerant used for absorption refrigerators working heat from solar collectors is mixture of water and

- (a) Carbon dioxide (b) Sulphur dioxide
(c) Lithium bromide (d) Freon 12

[ESE : 1996]

2.9 Match List-I with those in List-II and List-III and select the correct answer using the code given below the lists:

List-I

- A. Reversed Carnot engine
- B. Subcooling
- C. Superheating
- D. Constant enthalpy

List-II

1. Condenser
2. Evaporator
3. Vortex refrigerator
4. Throttling
5. Heat pump

List-III

6. Generator
7. Increase in refrigerating effect
8. Highest COP
9. Adiabatic
10. Dry compression

Codes:

	A	B	C	D
(a)	3, 10	1, 7	2, 9	4, 6
(b)	5, 8	1, 7	2, 10	4, 9
(c)	4, 10	3, 8	3, 10	1, 6
(d)	2, 7	5, 8	4, 6	1, 9

[ESE : 1996]

2.10 Consider the following statements:

In ammonia refrigeration systems, oil separator is provided because

1. Oil separation in evaporator would lead to reduction in heat transfer coefficient.
2. Oil accumulation in the evaporator causes choking of evaporator.
3. Oil is partially miscible in the refrigerant.
4. Oil cause choking of expansion device.

Which of these statements are correct?

- (a) 1 and 2 (b) 2 and 4
(c) 2, 3 and 4 (d) 1, 3 and 4

[ESE : 1996]

2.11 Consider the following statements:

Moisture should be removed from refrigerants to avoid

1. Compressor seal failure.
2. Freezing at the expansion valve.
3. Restriction to refrigerant flow.
4. Corrosion of steel parts.

Which of these statements are correct?

- (a) 1, 2, 3 and 4 (b) 1 and 2
(c) 2, 3 and 4 (d) 1, 3 and 4

[ESE : 1996]

2.12 Which one of the following statements regarding COP of ammonia absorption system is correct?

- (a) a function of the temperature and pressure of the solution
- (b) a function of the pressure of the solution irrespective of the temperature
- (c) a function of the temperature of the solution alone
- (d) independent of the temperature and pressure of the solution

[ESE : 1997]

2.13 Consider the following statements:

In the case of a vapour compression machine, if the condensing temperature of the refrigerant is closer to the critical temperature, then there will be:

1. excessive power consumption
2. high compression
3. large volume flow

Which of these statements are correct?

- (a) 1, 2 and 3 (b) 1 and 2
(c) 2 and 3 (d) 1 and 3 [ESE : 1997]

2.14 A single-stage vapour compression refrigeration system cannot be used to produce ultra low temperatures because

- (a) refrigerants for ultra-low temperatures are not available
- (b) lubricants for ultra-low temperatures are not available
- (c) volumetric efficiency will decrease considerably
- (d) heat leakage into the system will be excessive [ESE : 1997]

2.15 Vapour absorption refrigeration system works using the

- (a) ability of a substance to get easily condensed or evaporated
- (b) ability of a vapour to get compressed or expanded
- (c) affinity of a substance for another substance
- (d) absorptivity of a substance [ESE : 1997]

2.16 In an ideal refrigeration (reversed Carnot) cycle, the condenser and evaporator temperatures are 27°C and -13°C respectively. The COP of this cycle would be

- (a) 6.5 (b) 7.5
(c) 10.5 (d) 15.0 [ESE : 1997]

2.17 Air refrigeration cycle is used in

- (a) Commercial refrigerators
- (b) Domestic refrigerators
- (c) Gas liquefaction
- (d) Air-conditioning [ESE : 1998]

2.18 Match List I with List II and select the correct answer using the codes given below the lists:

List-I

- A. Bell Coleman refrigeration
- B. Vapour compression refrigeration
- C. Absorption refrigeration
- D. Jet refrigeration

List-II

1. Compressor
2. Generator
3. Flash chamber
4. Expansion cylinder

Codes:

- | | A | B | C | D | |
|-----|---|---|---|---|--------------|
| (a) | 1 | 4 | 3 | 2 | |
| (b) | 4 | 1 | 3 | 2 | |
| (c) | 1 | 4 | 2 | 3 | |
| (d) | 4 | 1 | 2 | 3 | [ESE : 1998] |

2.19 In milk chilling plants, the usual secondary refrigerant is

- (a) Ammonia solution
- (b) Sodium Silicate
- (c) Glycol
- (d) Brine [ESE : 1998]

2.20 The desirable combination of properties for a refrigerant include

- (a) High specific heat and low specific volume
- (b) High heat transfer coefficient and low latent heat
- (c) High thermal conductivity and low freezing point
- (d) High specific heat and high boiling point [ESE : 1998]

2.21 The flash chamber in a single stage simple vapour compression cycle

- (a) Increases the refrigerating effect
- (b) Decreases the refrigerating effect
- (c) Increases the work of compression
- (d) Has no effect on refrigerating effect [ESE : 1998]

2.22 Consider the following statements:

In a vapour compression system, a thermometer placed in the liquid line can indicate whether the

1. Refrigerant flow is too low
2. Water circulation is adequate
3. Condenser is fouled
4. Pump is functioning properly

Which of these statements are correct?

- (a) 1, 2 and 3 (b) 1, 2 and 4
(c) 1, 3 and 4 (d) 2, 3 and 4 [ESE : 1998]

2.23 The maximum *COP* for the absorption cycle is given by (T_G = generator temperature, T_C = environment temperature, T_E = refrigerated space temperature)

$$(a) \frac{T_E(T_G - T_C)}{T_G(T_C - T_E)} \quad (b) \frac{T_G(T_C - T_E)}{T_E(T_G - T_C)}$$

$$(c) \frac{T_C(T_G - T_E)}{T_G(T_C - T_E)} \quad (d) \frac{T_G(T_C - T_E)}{T_C(T_G - T_E)}$$

[ESE : 1998]

2.24 The coefficient of performance of a refrigerator working on a reversed Carnot cycle is 4. The ratio of the highest absolute temperature to the lowest absolute temperature is

- (a) 1.2 (b) 1.25
(c) 3.33 (d) 4

[ESE : 1999]

2.25 In vapour compression plant, if certain temperature differences are to be maintained in the evaporator and condenser in order to obtain the necessary heat transfer, then the evaporator saturation temperature must be

- (a) Higher than the derived cold-region temperature and the condenser saturation temperature must be lower than the available cooling water temperature by sufficient amounts
(b) Lower than the derived cold-region temperature and the condenser saturation temperature must be lower than the available cooling water temperature by sufficient amounts
(c) Lower than the derived cold-region temperature and the condenser saturation temperature must be higher than the available cooling water temperature by sufficient amounts

- (d) Higher than the derived cold-region temperature and the condenser saturation temperature must be higher than the available cooling water temperature by sufficient amounts

[ESE : 1999]

2.26 The correct sequence of the given components of a vapour compression refrigerator is

- (a) Evaporator, compressor, condenser and throttle valve
(b) Condenser, throttle valve, evaporator and compressor
(c) Compressor, condenser, throttle valve and evaporator
(d) Throttle valve, evaporator, compressor and condenser

[ESE : 1999]

2.27 The most common type of absorption system used in industrial applications is based on the refrigerant-absorbent combination of

- (a) Air-water
(b) Lithium bromide-air
(c) Carbon dioxide-water
(d) Ammonia-water

[ESE : 1999]

2.28 A good refrigerant should have

- (a) Large latent heat of vaporisation and low operating pressures
(b) Small latent heat of vaporisation and high operating pressures
(c) Large latent heat of vaporisation and large operating pressures
(d) Small latent heat of vaporisation and low operating pressures

[ESE : 1999]

2.29 Solar energy can be directly used in

- (a) Vapour compression refrigeration system
(b) Vapour absorption refrigeration system
(c) Air refrigeration system
(d) Jet refrigeration system

[ESE : 1999]

■■■■

Answers Ideal, Vapour, Air Refrigeration Cycle and Refrigerants

- 2.1 (b) 2.2 (b) 2.3 (d) 2.4 (c) 2.5 (b) 2.6 (d) 2.7 (c) 2.8 (c) 2.9 (b)
2.10 (a) 2.11 (a) 2.12 (c) 2.13 (a) 2.14 (c) 2.15 (c) 2.16 (a) 2.17 (c) 2.18 (d)
2.19 (d) 2.20 (c) 2.21 (d) 2.22 (a) 2.23 (a) 2.24 (b) 2.25 (c) 2.26 (c) 2.27 (d)
2.28 (a) 2.29 (b)

Explanations Ideal, Vapour, Air Refrigeration Cycle and Refrigerants**2.1 (b)**

In vapour absorption cycle generator is used. The generator is heated with the waste heat coming out from boiler, gas turbine or solar energy etc.

2.2 (b)

- (i) **Ammonia:** It is commonly used in ice factories and breweries without exception. The reasons for this are as follows:
- lowest running cost
 - cheapest refrigerant
 - leaks easy to detect
- (ii) **Carbon Dioxide:** It was widely used for air-conditioning hospitals, theaters, hotels and marine service where safety was the prime consideration.
- (iii) **Refrigerant-11:** Due to the low operating pressures, centrifugal compressors are used to handle the large volume at low pressure. It is mainly used for airconditioning office building, factories department stores and theaters.
- (iv) **Air:** The dry air is used as a gaseous refrigerant in some compression system, particularly in air-craft air conditioning.

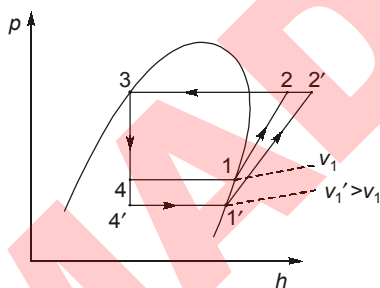
2.4 (c)

It is observed that a decreased in evaporator temperature results in:

- Decrease in refrigerating effect from $(h_1 - h_4)$ to $(h_1' - h_4')$
- Increase in the specific volume of suction vapour from v_1 to v_1'
- Decrease in volumetric efficiency, due to increase in the pressure ratio, from η_v to η_v'
- Increase in compressor work from $(h_2 - h_1)$ to $(h_2' - h_1')$ due to increase in the pressure ratio as well as change from steeper isentropic 1-2 to flatter isentropic 1'-2'.

2.5 (b)

In vapour compression refrigeration, the expansion cylinder system of expanding the liquid refrigerant is quite complicated and involves greater initial cost. Therefore its use is not justified for small save in work. Moreover, the flow rate of the refrigerant can be controlled with throttle valve which is not possible in case of expansion cylinder which has a fixed cylinder volume.

2.6 (d)

- (i) Practically all common refrigeration have approximately the same COP and power requirement

Refrigerant	COP	kW/ton
NH ₃	4.76	0.75
CO ₂	2.56	1.4
SO ₂	4.87	0.74
R-11	5.09	0.71
R-12	4.7	0.76
R-22	4.6	0.77
R-113	4.92	0.73

- Ammonia is immisible with oil.
- The dielectric strength of the refrigerant becomes an important factor when it is used in hermetically sealed unit where the motor is exposed to the refrigerant.

The dielectric strength of different refrigerant vapours are compared with dielectric strength of nitrogen, therefore, the relative dielectric strength of refrigerant vapour are given by a ratio by

$$= \frac{\text{Dielectric strength of refrigerant vapour}}{\text{Dielectric strength of nitrogen}}$$

- The leaks of ammonia refrigerant may be quickly and easily detected by use of burning sulphur candle which in the presence of ammonia forms white fumes of ammonia sulphite.
- The leakage of fluoro-carbon refrigerants can be detected by soap solution.

2.7 (c)

$$\text{Flow work} = \int -vdp$$

Since, specific volume of liquid is very small hence work obtained will not justify the cost of expander. Secondly, the frictional and thermodynamic losses in expanding the liquid will make the gain in work negative. So isentropic process of expansion is replaced by isenthalpic process through throttling.

2.8 (c)

Absorption refrigerators working by solar collector uses mixture of water and Lithium bromide (water-LiBr).

2.10 (a)

A built-up of oil in the evaporator will result in a reduced heat transfer coefficient, oil choking in the evaporator due to restriction to refrigerant flow and even blockage and ultimately to oil starvation in the compressor.

2.12 (c)

It is function of temperature only as the vapour refrigerant from the evaporator is drawn into an absorbs where it is absorbed by weak solution of the refrigerant forming strong solution. This strong solution is pumped to the generator where it is heated by some external source. During the heating process the vapour refrigerant is driven off by the solution and enters into the condenser where it is liquefied. So it function of temperature only.

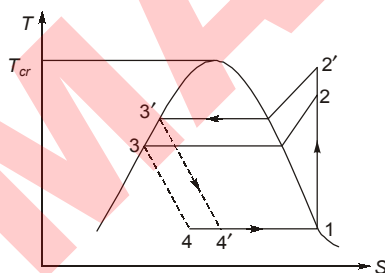
2.13 (a)

As the condensing temperature of the refrigerant is closer to the critical temperature, then there will be

- power consumption increase from $m(h_2 - h_1)$ to $m(h'_2 - h_1)$.
- high compression ratio.
- increase in volume flow rate for same power.

- decrease in refrigeration effect from $m(h_1 - h_4)$ to $m(h_1 - h'_4)$.
- decrease in COP.

2.14 (c)

To produce ultra-low temperature the compression ratio will increase, the volumetric efficiency will decrease.

2.15 (c)

The affinity of substance to get absorbed and evaporated easily is the prime requirement for being in use.

2.16 (a)

Given data :

$$T_1 = 27^\circ\text{C} = (27 + 273) \text{ K} = 300 \text{ K}$$

$$T_2 = -13^\circ\text{C} = (-13 + 273) \text{ K} = 260 \text{ K}$$

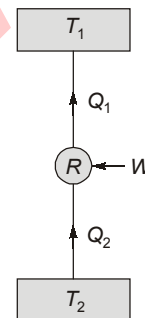

$$(COP)_R = \frac{T_2}{T_1 - T_2} = \frac{260}{300 - 260} = 6.5$$

2.17 (c)

Air refrigeration is used widely for gas liquefaction.

2.18 (d)

1. Bell-Coleman refrigeration : Expansion cylinder
2. Vapour compression refrigeration : Compressor
3. Absorption refrigeration : Generator
4. Jet refrigeration : Flash chamber

2.20 (c)

The desirable properties of ideal refrigerant are:

- (i) Low boiling point
- (ii) Low freezing point
- (iii) High critical temperature
- (iv) High latent heat of vaporization

- (v) Low specific heat of liquid
- (vi) Low specific volume of vapour
- (vii) Noncorrosive metal
- (viii) High heat-transfer coefficient

2.21 (d)

The use of flash chamber has no effect on the thermodynamic cycle. The only effect resulting from the use of flash chamber is the reduction in the mass of refrigerant flowing through the evaporator and hence the reduction in the size of evaporator.

2.23 (a)

$$(COP)_{VAS} = \eta_{carnot} \times (COP)_{carnot}$$

$$= \left(\frac{T_G - T_C}{T_G} \right) \left(\frac{T_E}{T_C - T_E} \right)$$

2.24 (b)

$$COP = \frac{T_L}{T_H - T_L} = 4$$

$$\frac{T_H - T_L}{T_L} = 0.25$$

$$\frac{T_H}{T_L} - 1 = 0.25$$

$$\frac{T_H}{T_L} = 1.25$$

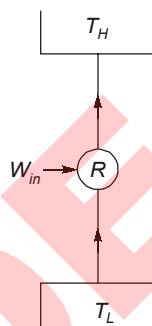

2.25 (c)

To have heat transfer evaporator temperature should be less than required temperature and condenser temperature should be higher.

2.26 (c)

Always sequence start from compressor then condenser, throttle valve and evaporator

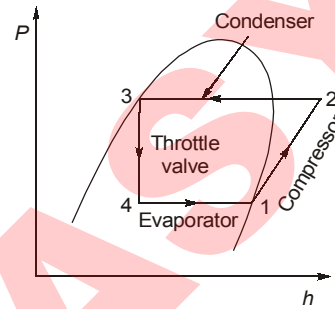

2.27 (d)

For industrial application, Ammonia-water (Aqua-ammonia) absorption system is widely used.

2.28 (a)

The desirable properties of ideal refrigerant are:

- (i) Low boiling point
- (ii) Low freezing point
- (iii) High critical temperature
- (iv) High latent heat of vaporization
- (v) Low specific heat of liquid
- (vi) Low specific volume of vapour
- (vii) Noncorrosive metal
- (viii) High heat-transfer coefficient



3

Refrigeration Equipments

3.1 A pressure gauge on discharge side of a refrigerant compressor reads too high. The reason could be :

1. lack of cooling water
2. water temperature being high
3. dirty condenser surface
4. refrigerant temperature being too high

Which of these statements are correct?

- (a) 1, 2 and 4 (b) 1, 2 and 3
(c) 2, 3 and 4 (d) 1, 2, 3 and 4

[ESE : 1995]

3.2 Assertion (A): Never connect a solenoid valve directly to the motor leads.

Reason (R): The high current drawn to start the motor may drop the voltage enough to prevent the valve from opening.

- (a) Both **A** and **R** are individually true and **R** is the correct explanation of **A**
(b) Both **A** and **R** are individually true but **R** is not the correct explanation of **A**
(c) **A** is true but **R** is false
(d) **A** is false but **R** is true

[ESE : 1995]

3.3 When the discharge pressure is too high in refrigeration system, high pressure control is installed to

- (a) stop the cooling fan
- (b) stop the water circulating pump
- (c) regulate the flow of cooling water
- (d) stop the compressor

[ESE : 1996]

3.4 For large tonnage (more than 200 tons) air-conditioning applications, which one of the following types of compressors is recommended?

- (a) Reciprocating (b) Rotating
(c) Centrifugal (d) Screw

[ESE : 1996]

3.5 Air cooling is used for freon compressors whereas water jacketing is adopted for cooling ammonia compressors. This is because

- (a) latent heat of ammonia is higher than that of freon
(b) thermal conductivity of water is higher than that of air
(c) specific heat of water is higher than that of air
(d) of the larger superheat horn of ammonia compression cycle

[ESE : 1997]

3.6 For an air-conditioning plant above 300 ton, which one of the following system would normally be preferred?

- (a) Ammonia reciprocating compressor
(b) Centrifugal chiller
(c) Absorption refrigeration system
(d) Hermetic compressor

[ESE : 1997]

3.7 When a burnt out hermetic compressor is replaced by a new one, it is desirable to include in the system a large drier-cum strainer also. This is to be placed in

- (a) Liquid line (b) Suction line
(c) Hot gas line (d) Discharge line

[ESE : 1999]



Answers Refrigeration Equipments

- 3.1** (b) **3.2** (a) **3.3** (d) **3.4** (c) **3.5** (d) **3.6** (b) **3.7** (a)

Explanations Refrigeration Equipments**3.3 (d)**

The high pressure control is used as safety control. The compressor is stopped by cutting off the power supply given to the motor of the compressor, whenever the discharge pressure of the compressor becomes excessive. This is necessary to prevent the possible damages of the equipments.

3.4 (c)

Centrifugal compressors are used for system ranging from 50 to 5000 tonnes.

3.5 (d)

The compressor discharge temperature of ammonia is very high due to high value of adiabatic index (γ).

3.6 (b)

The reciprocating compressors are available in size as small as 1/2 kW which are used in small domestic refrigerators and upto about 150 kW (42.857 tons) for large capacity installation. The centrifugal compressor are especially adapted for system ranging from 50 to 500 tonnes.

The vapour absorption system can be built in capacity well above 1000 tonnes of refrigeration each which is the largest size for single compressor units.

3.7 (a)

A drier is connected between the receiver and the evaporator to eliminate traces of moisture if any.

■■■■

4

Psychrometry and Psychrometric Processes

4.1 Consider the following statements:

In psychrometry, wet-bulb temperature is a measure of enthalpy of moist air, so that in the psychrometric chart,

1. The constant enthalpy lines are also constant wet bulb temperature lines.
2. The wet bulb and dry bulb temperature are same at any condition.
3. The wet bulb and dry-bulb temperature are equal at saturation condition.

Which of these statements is/are correct?

- (a) 1 only (b) 1 and 2
(c) 1 and 3 (d) 2 and 3

[ESE : 1995]

4.2 At 100% relative humidity, the wet bulb temperature is

- (a) more than dew point temperature
(b) same as dew point temperature
(c) less than dew point temperature
(d) equal to ambient temperature

[ESE : 1995]

4.3 Evaporative air-cooler is used effectively when

- (a) dry bulb temperature is very close to the wet bulb temperature
(b) dry bulb temperature is high and relative humidity is high
(c) dry bulb temperature is low and relative humidity is high
(d) dry bulb temperature is high and the relative humidity is low

[ESE : 1995]

4.4 The minimum temperature to which water can be cooled in a cooling tower is

- (a) the dew point temperature of air
(b) the wet bulb temperature of air
(c) the dry bulb temperature of air
(d) the ambient air temperature

[ESE : 1995]

4.5 During the adiabatic cooling of moist air

- (a) DBT remains constant
(b) Specific humidity remains constant

- (c) Relative humidity remains constant
(d) WBT remains constant

[ESE : 1996]

4.6 When a stream of moist air is passed over a cold and dry cooling coil such that no condensation takes place, then the air stream will get cooled along the line of

- (a) constant wet bulb temperature
(b) constant dew point temperature
(c) constant relative humidity
(d) constant enthalpy

[ESE : 1996]

4.7 Consider the following statements:

A psychrometer measures

1. wet bulb temperature
2. dew point temperature
3. dry bulb temperature

Which of these statements is/are correct?

- (a) 1 only (b) 2 and 3
(c) 1 and 3 (d) 1, 2 and 3

[ESE : 1997]

4.8 To fix the state point in respect of air-vapour mixtures, three intrinsic properties are needed. Yet, the psychrometric chart requires only two because

- (a) water vapour is in the superheated state
(b) the chart is for a given pressure
(c) the chart is an approximation to true values
(d) the mixtures can be treated as a perfect gas

[ESE : 1998]

4.9 During sensible cooling of air

- (a) Its wet bulb temperature increases and dew point remains constant
(b) Its wet bulb temperature decreases and the dew point remains constant
(c) Its wet bulb temperature increases and the dew point decreases
(d) Its wet bulb temperature decreases and dew point increases

[ESE : 1998]

4.10 The expression $\frac{0.622 p_v}{p_t - p_v}$ is used to determine

- (a) Relative humidity
- (b) Specific humidity
- (c) Degree of saturation
- (d) Partial Pressure

[ESE : 1998]

4.11 The effective temperature is a measure of the combined effects of

- (a) Dry bulb temperature and relative humidity
- (b) Dry bulb temperature and air motion
- (c) Wet bulb temperature and air motion
- (d) Dry bulb temperature, relative humidity and air motion

[ESE : 1998]

4.12 A human body feels comfortable when the heat produced due to metabolism of human body is equal to the

- (a) Heat dissipated to the surroundings
- (b) Heat stored in human body
- (c) Difference between heat dissipated to the surroundings and heat stored in human body
- (d) Sum of heat dissipated to the surroundings and heat stored in human body

[ESE : 1999]

4.13 The reason for a person feeling more comfortable on a warm day if seated in front of an electric fan is that the

- (a) Metabolic heat production is reduced
- (b) Body loses more heat by convection and evaporation
- (c) Body loses more heat by radiation
- (d) Body loses more heat by evaporation and radiation

[ESE : 1999]

4.14 The equation $\phi = \frac{p_v}{p_s}$ is used to calculate the

(p_v = partial pressure of water vapour in moist air at a given temperature,

p_s = saturation pressure of water vapour at the same temperature)

- (a) Relative humidity
- (b) Degree of saturation
- (c) Specific humidity
- (d) Absolute humidity

[ESE : 1999]

4.15 During adiabatic saturation process of air, wet bulb temperature

- (a) increases and dry bulb temperature remains constant
- (b) remains constant and dry bulb temperature increases
- (c) remains constant and dry bulb temperature decreases
- (d) decreases and dry bulb temperature remains constant

[ESE : 1999]

4.16 In a chilled-water spray pond, the temperature of water is lower than dew point temperature of entering air. The air passing through the spray undergoes

- (a) Cooling and humidification
- (b) Cooling and dehumidification
- (c) Sensible cooling
- (d) Dehumidification

[ESE : 1999]

4.17 The performance of an evaporation condenser largely depends on

- (a) Dry bulb temperature of air
- (b) Wet bulb temperature of air
- (c) Hot water temperature
- (d) Air-conditioned room temperature

[ESE : 1999]

4.18 Air at state 1 (DPT 10°C, $\omega = 0.0040$ kg/kg of dry air) mixes with air at state 2 (DPT 18°C $\omega = 0.0051$ kg/kg of dry air) in the ratio 1 to 3 by weight. The degree of saturation (%) of the mixture is (the specific humidity of saturated air at 13.6°C, $\omega = 0.01$ kg/kg of dry air)

- (a) 25
- (b) 30
- (c) 48
- (d) 62

[ESE : 1999]

■■■■

Answers Psychrometry and Psychrometric Processes

- 4.1 (c) 4.2 (b) 4.3 (d) 4.4 (b) 4.5 (d) 4.6 (b) 4.7 (c) 4.8 (b) 4.9 (b)
 4.10 (b) 4.11 (d) 4.12 (d) 4.13 (b) 4.14 (a) 4.15 (c) 4.16 (b) 4.17 (b) 4.18 (c)

Explanations Psychrometry and Psychrometric Processes**4.1 (c)**

On a psychrometric chart the constant enthalpy lines are also constant wet-bulb temperature lines. The wet bulb and dry bulb temperature are equal at saturation condition (100% relative humidity)

4.2 (b)

For fully saturated air

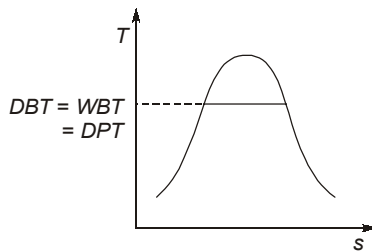
**4.3 (d)**

Evaporative air-cooler used effectively when dry-bulb temperature is high and the relative humidity is low. The evaporative cooling is only successful in those areas where reasonably low wet bulb (31°C and below) occurs simultaneously with dry bulb temperature (35°C above).

4.4 (b)

In case of cooling tower minimum temperature to which the water can be cooled is wet bulb temperature of inlet air.

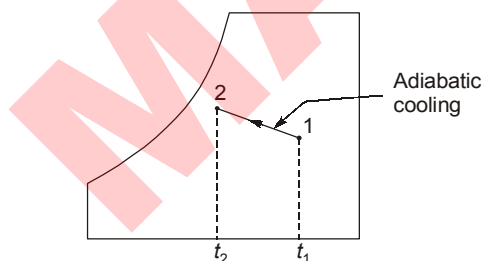
4.5 (d)

During adiabatic cooling of moist air, enthalpy of moist air remains constant. Since constant enthalpy lines and constant wet bulb temperature lines are same hence wet bulb temperature also remains constant during adiabatic cooling.

4.6 (b)

When a stream of moist air is passed over a cold and dry cooling coil such that no condensation takes place, then sensible cooling takes place which is constant dew point temperature process.

4.7 (c)

Psychrometer measures only dry bulb temperature and wet bulb temperature. Sling psychrometer is also its name.

4.8 (b)

The psychrometric chart is based on given fixed pressure.

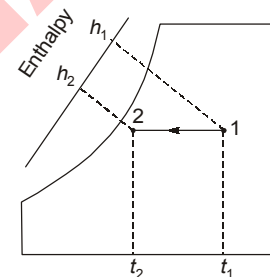
4.9 (b)

Dew point temperature remains constant during sensible cooling and wet bulb temperature decreases.

4.10 (b)

$$\text{Specific humidity: } \omega = \frac{0.622 p_v}{p_t - p_v}$$

4.11 (d)

The effective temperature is measure of dry bulb temperature, relative humidity and air motion.

4.12 (d)

A human body feels comfortable when the heat produced by metabolism of human body is equal to the sum of the heat dissipated to the surrounding and the heat stored in human body by raising the temperature body.

Heat produced by the body = Heat dissipated to surroundings + Heat stored in body

4.13 (b)

Person loses more heat due to forced convection and due to this he feels more comfortable.

4.14 (a)

Relative humidity gives the relativeness about the mass of water present for given condition to the mass of water present in the same volume of saturated state for given pressure and temperature.

$$\phi = \frac{\rho_v}{\rho_{vs}}$$

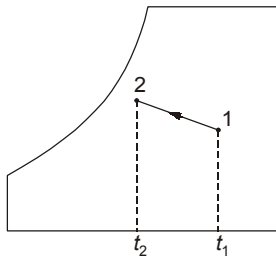
4.15 (c)

So during adiabatic saturation process wet bulb temperature remains constant and dry bulb temperature decreases.

4.16 (b)

Cooling and dehumidification may be accomplished with help of an air-washer. In the air-washer system, the outside or entering air is cooled below its dew point temperature so that it loses moisture by condensation. The moisture removal is also accomplished when the spray water is chilled water and its temperature is lower than dew point temperature of the entering air.

4.18 (c)

$$\begin{aligned} \text{kg of moisture actually contained in mixture} \\ = \frac{0.004 + 3 \times 0.0051}{3 + 1} = 0.0048 \end{aligned}$$

$$\begin{aligned} \text{kg of moisture in saturated air of mixture} \\ = 0.01 \text{ kg / kg of air} \end{aligned}$$

$$\begin{aligned} \therefore \text{Degree of saturation} &= \frac{0.0048}{0.01} \times 100 \\ &= \mathbf{48\%} \end{aligned}$$

■■■■

5

Cooling Load Calculations and Duct Design

- 5.1** Two summer air-conditioning systems with non-zero by pass factor are proposed for a room with a known sensible and latent heat load. System *A* operates with ventilation but system *B* operates without ventilation. Then the
- by-pass factor of system *A* must be less than the by-pass factor of system *B*
 - by-pass factor of system *A* must be more than the by-pass factor of system *B*
 - apparatus dew point for system *A* must be lower than the apparatus dew point for system *B*
 - apparatus dew point for system *A* must be higher than the apparatus dew point for system *B*. [ESE : 1995]
- 5.2** The most commonly used method for the design of duct size is the
- velocity reduction method
 - equal friction method
 - static region method
 - dual or double duct method [ESE : 1996]
- 5.3 Assertion (A):** In an air-conditioned room, the reflective coating should be on the inside of the Window.
Reason (R): Plane window glass is transparent to solar radiation.
- Both **A** and **R** are individually true and **R** is the correct explanation of **A**
 - Both **A** and **R** are individually true but **R** is not the correct explanation of **A**
 - A** is true but **R** is false
 - A** is false but **R** is true [ESE : 1996]
- 5.4** Fresh air intake (air change per hour) recommended for ventilation purposes in the air-conditioning system of an office building is
- 1/2
 - 3/2
 - 9/2
 - 25/2 [ESE : 1997]
- 5.5** For low by-pass factor of cooling coil, the fin spacing and the number of tube rows will be respectively
- High and high
 - High and low
 - Low and high
 - Low and low [ESE : 1998]
- 5.6** In air-conditioning design for summer months, the condition inside a factory where heavy work is performed as compared to a factory in which light work is performed should have
- Lower dry bulb temperature and lower relative humidity
 - Lower dry bulb temperature and higher relative humidity
 - Lower dry bulb temperature and same relative humidity
 - Same dry bulb temperature and same relative humidity [ESE : 1998]
- 5.7** Which of the following method (s) is/are adopted in the design of air duct system?
- Velocity reduction method
 - Equal friction method
 - Static regain method
- Select the correct answer using the codes given below:
- 1 only
 - 1 and 2
 - 2 and 3
 - 1, 2 and 3 [ESE : 1998]
- 5.8** The sensible heat factor of a room is given by (SHL = Sensible heat load and LHL = Latent heat load)
- $\frac{SHL - LHL}{SHL}$
 - $\frac{SHL}{SHL - LHL}$
 - $\frac{SHL + LHL}{SHL}$
 - $\frac{SHL}{SHL + LHL}$ [ESE : 1999]

- 5.9 Air at 20°C dry bulb temperature and 40% relative humidity is heated upon 40°C using an electric heater, whose surface temperature is maintained uniformly at 45°C. The by-pass factor of the heater is
- (a) 0.20 (b) 0.25
(c) 0.88 (d) 1

[ESE : 1999]

■■■■

Answers Cooling Load Calculations and Duct Design

- 5.1 (b) 5.2 (b) 5.3 (d) 5.4 (d) 5.5 (c) 5.6 (a) 5.7 (d) 5.8 (d) 5.9 (a)

Explanations Cooling Load Calculations and Duct Design**5.1 (b)**

In cooling coil, bypass factor is the difference between leaving air temperature and the mean coil surface temperature divided by the difference between the entering air temperature and mean surface temperature

$$\text{BPF} = \frac{t_2 - t_3}{t_1 - t_3}$$

BPF shows degree to which coils are inefficient. Due to ventilation room temperature increases, because of that bypass factor increases.

5.2 (b)

Equal friction method must commonly be used method for the design of duct because of its economical.

Other methods are:

- (i) velocity reduction method
- (ii) static regain methods

5.4 (d)

The proportion of fresh air intake is more in case of air conditioning in office because of large number of people working over there.

5.5 (c)

By-pass factor of cooling coil decreases with decrease in fin spacing and increase in number of rows. This will increase the contact of gas with the coil.

5.6 (a)

Lower dry bulb temperature and lower relative humidity is required for given condition because of heavy work conditions. Large amount of heat produced which increases the dry bulb temperature and relative humidity.

5.8 (d)

$$\text{SHF} = \frac{\text{SHL}}{\text{SHL} + \text{LHL}}$$

5.9 (a)

Given: $t_1 = 20^\circ\text{C}$; $t_2 = 40^\circ\text{C}$; $t_3 = 45^\circ\text{C}$

$$\text{BPF} = \frac{t_3 - t_2}{t_3 - t_1} = \frac{45 - 40}{45 - 20} = 0.2$$

■■■■

UNIT

VI

Turbo Machinery

Syllabus

Reciprocating and Rotary pumps, Pelton wheel, Kaplan and Francis Turbines, velocity diagrams, Impulse and Reaction principles, Steam and Gas Turbines, Theory of Jet Propulsion – Pulse jet and Ram Jet Engines, Reciprocating and Rotary Compressors – Theory and Applications.

Contents

Sl.	Topic	Page No.
1.	Impact of Jet and Hydraulic Turbines	119
2.	Hydraulic Pumps	123
3.	Hydraulic Machines	126
4.	Air Compressors (Reciprocating and Rotary)	127
5.	Steam Turbines	134
6.	Gas Turbines	141
7.	Jet Propulsion and Compressible Flow	146

1

Impact of Jet and Hydraulic Turbines

1.1 A hydraulic power station has the following major items in the hydraulic circuit:

1. Draft tube
2. Runner
3. Guide wheel
4. Penstock

The correct sequence of these items in the direction of flow is

- (a) 4, 2, 3, 1 (b) 4, 3, 2, 1
(c) 1, 2, 3, 4 (d) 1, 3, 2, 4

[ESE : 1995]

1.2 The movable wicket gates of a reaction turbine are used to

- (a) control the flow of water passing through the turbine
(b) control the pressure under which the turbine is working
(c) strengthen the casing of the turbine
(d) reduce the size of the turbine

[ESE : 1995]

1.3 Euler equation for water turbine is derived on the basis of

- (a) conservation of mass
(b) rate of change of linear momentum
(c) rate of change of angular momentum
(d) rate of change of velocity

[ESE : 1995]

1.4 Which one of the following sketches represents an impulse turbine blade?

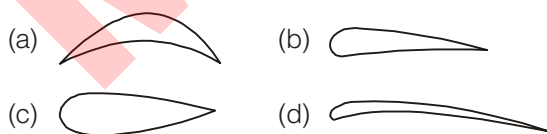

[ESE : 1995]

1.5 The specific speed of a turbine is defined as the speed of a member of the same homologous series of such a size that it

- (a) delivers unit discharge at unit head
(b) delivers unit discharge at unit power

- (c) delivers unit power at unit discharge
(d) produces unit power under the unit head

[ESE : 1996]

1.6 Match List-I with List-II and select the correct answer using the codes given below the lists:

List-I

- A. Pelton wheel (single jet)
B. Francis turbine
C. Kaplan turbine

List-II

1. Medium discharge, low head
2. High discharge, low head
3. Medium discharge, medium head
4. Low discharge, high head

Codes:

- | | A | B | C |
|-----|---|---|---|
| (a) | 1 | 2 | 3 |
| (b) | 1 | 3 | 4 |
| (c) | 4 | 1 | 3 |
| (d) | 4 | 3 | 2 |

[ESE : 1996]

1.7 In reaction turbines, the draft tube is used

- (a) for the safety of the turbine
(b) to convert the kinetic energy of flow by a gradual expansion of the flow cross-section
(c) to destroy the undesirable eddies
(d) for none of the above purposes

[ESE : 1996]

1.8 As water flows through the runner of a reaction turbine, pressure acting on it would vary from

- (a) more than atmospheric pressure to vacuum
(b) less than atmospheric pressure to zero gauge pressure
(c) atmospheric pressure to more than atmospheric pressure
(d) atmospheric pressure to vacuum

[ESE : 1997]

1.9 A reaction turbine discharges 30 m³/s of water under a head of 10 m with an overall efficiency of 92%. The power developed is

- (a) 295.2 kW (b) 287.0 kW
(c) 279.0 kW (d) 265.2 kW

[ESE : 1997]

1.10 Given that N = speed, P = power, H = head
The specific speed of a hydraulic turbine is given by

- (a) $\frac{N\sqrt{P}}{H^{4/5}}$ (b) $\frac{N\sqrt{P}}{H^{5/4}}$
(c) $\frac{P\sqrt{N}}{H^{4/5}}$ (d) $\frac{P\sqrt{N}}{H^{5/4}}$

[ESE : 1997]

1.11 Which one of the following statements regarding an impulse turbine is correct?

- (a) There is no pressure variation in flow over the buckets and the fluid fills the passageway between the buckets.
(b) There is no pressure variation in flow over the buckets and the fluid does not fill the passageways between the buckets.
(c) There is pressure drop in flow over the buckets and the fluid fills the passageways between the buckets.
(d) There is pressure drop in flow over the buckets and the fluid does not fill the passageway between the buckets.

[ESE : 1997]

1.12 Which one of the following forms of draft tube will not improve the hydraulic efficiency of the turbine?

- (a) Straight cylindrical
(b) Conical type
(c) Bell-mouthed
(d) Bent tube

[ESE : 1998]

1.13 Which one of the following turbines is used in underwater power stations?

- (a) Pelton turbine (b) Deriaz turbine
(c) Tubular turbine (d) Turgo-impulse turbine

[ESE : 1998]

1.14 A Pelton wheel is ideally suited for

- (a) high head and low discharge
(b) high head and high discharge
(c) low head and low discharge
(d) medium head and medium discharge

[ESE : 1998]

1.15 Consider the following turbines:

1. Kaplan 2. Pelton wheel 3. Francis

The correct sequence in increasing order of the specific speeds of these turbines is

- (a) 2, 3, 1 (b) 2, 1, 3
(c) 3, 1, 2 (d) 1, 2, 3

[ESE : 1998]

1.16 Consider the following statements:

1. A draft tube may be fitted to the tail end of a Pelton turbine to increase the available head.
2. Kaplan turbine is an axial flow reaction turbine with adjustable vanes on the hub.
3. Modern Francis turbine is a mixed flow reaction turbine.

Which of these statements are correct?

- (a) 1, 2 and 3 (b) 1 and 2
(c) 2 and 3 (d) 1 and 3

[ESE : 1999]

1.17 The correct sequence of the given hydraulic turbines in decreasing order of their specific speeds is

- (a) Pelton wheel, Francis turbine and Kaplan turbine
(b) Propeller turbine, Francis turbine and Pelton wheel
(c) Kaplan turbine, Pelton wheel and Francis turbine
(d) Francis turbine, Kaplan turbine and Pelton wheel

[ESE : 1999]



Answers Impact of Jet and Hydraulic Turbines

1.1 (b) 1.2 (a) 1.3 (c) 1.4 (a) 1.5 (d) 1.6 (d) 1.7 (b) 1.8 (a) 1.9. (*)

1.10 (b) 1.11 (b) 1.12 (a) 1.13 (c) 1.14 (a) 1.15 (a) 1.16 (c) 1.17 (b)

Explanations Impact of Jet and Hydraulic Turbines

1.1 (b)

Penstock: It is used to carry water from dam to the inlet of turbine.

Guide wheel: It controls the flow of water to the turbine runner.

Draft tube: It is used in reaction turbine and located after turbine.

1.2 (a)

Water enters the adjustable guide vanes or wicket gates are pivoted and can be turned suitably to control the flow and output. The purpose of the guide vanes is to impart a whirl component of velocity or angular momentum of water before entering the runner.

1.3 (c)

Eulers equation for water turbine is:

$$H = \frac{U_2^2 - U_1^2}{2g} + \frac{V_2^2 - V_1^2}{2g} + \frac{V_{r1}^2 - V_{r2}^2}{2g}$$

$$= \left(\text{Centrifugal head} \right) + \left(\text{Kinetic head} \right) + \left(\text{Relative velocity head} \right)$$

1.5 (d)

Specific speed: It is defined as the speed of a similar turbine working under a head of 1m to produce a power output of 1kW. The specific speed is useful to compare the performance of various type of turbines. The specific speed differs for different types of turbines and is same for the model and actual turbine.

Specific speed:

$$N_s = \frac{N\sqrt{P}}{H^{5/4}}$$

1.6 (d)

Characteristics of Pelton wheel

- Impulse turbine
- High head turbine (300 – 2000 m)
- Low specific discharge turbine
- Tangential flow turbine
- Low specific speed turbine (4 – 70)

Characteristics of Francis turbine

- Reaction turbine
- Medium head turbine (30 – 500 m)

- Medium specific discharge
- Radial flow turbine, but modern francis turbine are mixed flow turbine
- Medium specific speed turbine (60 – 400 V)

Characteristics of Kaplan turbine

- Reaction turbine
- Low head turbine (2 m – 70 m)
- High specific discharge
- Axial flow
- High specific speed (300 – 1100)

1.7 (b)

The draft tube has two purposes as follows:

- It permits a negative or suction head to be established at the runner exit, thus making it possible to install the turbine above the tail race level without loss of head.
- It converts a large proportion of velocity energy rejected from the runner into useful pressure energy. i.e. acts as a recuperator of pressure energy.

1.8 (a)

At runner inlet the pressure is more than atmospheric pressure and at runner outlet pressure is less than atmospheric (vacuum).

1.9 (*)

$$\text{Water power} = \rho QgH = 1000 \times 30 \times 9.81 \times 10$$

$$= 2943 \times 10^3 \text{ W} = 2943 \text{ kW}$$

$$\text{Shaft power} = \eta_{\text{overall}} \times \text{Water power}$$

$$= \mathbf{2707.56 \text{ kW}}$$

1.10 (b)

The specific speed of turbine characterizes the turbine shape in a way that is not related to its size. The specific speed is the speed with which the turbine turns for a particular discharge, with unit head and thereby is able to produce unit power.

1.12 (a)

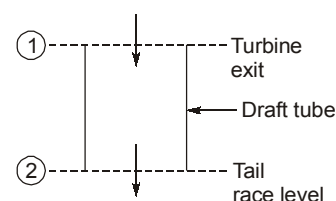

By equation of continuity

$$\rho_1 A_1 V_1 = \rho_2 A_2 V_2$$

∴ Water is incompressible, $\rho_1 = \rho_2$

$$\Rightarrow A_1 V_1 = A_2 V_2$$

Since $A_1 = A_2$

∴ Straight cylindrical

1.13 (c)

Tubular or bulb turbine are designed into the water delivery tube. A large bulb is centered in the water pipe which holds the generator, wicket gate and runner. Tubular turbine are a fully axial design.

1.14 (a)

$$\text{Specific speed } (N_s) = \frac{N\sqrt{P}}{H^{5/4}}$$

For high head, specific speed will be low, thus Pelton turbine is suitable, because specific speed is the speed with which the turbine turn for a particular discharge Q , with unit head and thereby is able to produce unit power, thus for low specific speed, discharge must be low.

1.15 (a)

Type of turbine	Specific speed
1. Propeller/Kaplan turbine	300-1000
2. Francis/Fourneyron's turbine	40-300
3. Pelton turbine	9-40

1.16 (c)

In a Pelton turbine, draft tube can't help to increase the available head since the jet from nozzle gets exposed to atmospheric air.

1.17 (b)

Specific speed of propeller is around 225-850, Francis 50-225 and Pelton 10-50.

■■■■

2

Hydraulic Pumps

2.1 Which of the following are the beneficial effects of air vessel fitted to delivery side of a reciprocating pump?

1. Constant rate of discharge can be ensured.
2. Power consumption can be reduced.
3. Discharge can be increased.
4. Constant velocity of the piston can be ensured.

Select the correct answer using the codes given below:

- (a) 1 and 4 (b) 1 and 2
(c) 2 and 4 (d) 1 and 3 [ESE : 1995]

2.2 For attaining a non-overloading characteristic in centrifugal pumps

- (a) backward bent vanes are preferred over forward bent vanes
- (b) forward bent vanes are preferred over backward bent vanes
- (c) forward bent vanes are preferred over vanes radial at outlet
- (d) vanes radial at outlet are preferred over backward vanes [ESE : 1995]

2.3 Consider the following statements:
Cavitation in hydraulic machines occurs at

1. the exit of a pump
2. the entry of the pump
3. the exit of a turbine

Which of these statements are correct?

- (a) 1 and 2 (b) 1 and 3
(c) 1, 2 and 3 (d) 2 and 3 [ESE : 1995]

2.4 Assertion (A): With increase in discharge in a single stage centrifugal pump the *BHP* goes on increasing but beyond a certain discharge the *BHP* starts decreasing.

Reason (R): Efficiency of the pump starts decreasing beyond a certain discharge.

- (a) Both **A** and **R** are individually true and **R** is the correct explanation of **A**
- (b) Both **A** and **R** are individually true but **R** is not the correct explanation of **A**

- (c) **A** is true but **R** is false
- (d) **A** is false but **R** is true [ESE : 1995]

2.5 Consider the following statements:
If pump *NPSH* requirements are not satisfied, then

1. it will not develop sufficient head to raise water
2. its efficiency will be low
3. it will deliver very low discharge
4. it will be cavitated

Which of these statements are correct?

- (a) 1, 2 and 3 (b) 1 and 4
(c) 2, 3 and 4 (d) 1, 2, 3 and 4 [ESE : 1996]

2.6 A centrifugal pump is started with its delivery valve kept

- (a) fully open (b) fully closed
- (c) partially open (d) 50% open [ESE : 1997]

2.7 Assertion (A): Pump lifts water from a lower level to a higher level.

Reason (R): In pump, mechanical energy is converted into pressure energy.

- (a) Both **A** and **R** are individually true and **R** is the correct explanation of **A**
- (b) Both **A** and **R** are individually true but **R** is not the correct explanation of **A**
- (c) **A** is true but **R** is false
- (d) **A** is false but **R** is true [ESE : 1997]

2.8 Given power *P* of a pump, the head *H*, the discharge *Q* and the specific weight *w* of liquid, dimensional analysis would lead to the result that *P* is proportional to

- (a) $H^{1/2}Q^2w$ (b) $H^{1/2}Qw$
- (c) $HQ^{1/2}w$ (d) HQw [ESE : 1998]

2.9 Consider the following statements regarding the specific speeds of a centrifugal pump:

1. Specific speed is defined as the speed of a geometrically similar pump developing unit power under unit head.

2. At the same specific speed, the efficiency is greater with larger capacity.
3. The specific speed increases with increase in outer blade angle.
4. The specific speed varies directly as the square root of the pump discharge.

Which of these statements are correct?

- (a) 1 and 2 (b) 2 and 4
(c) 3 and 4 (d) 2 and 3 [ESE : 1998]

2.10 Which of the following purposes are served by the volute casing of a centrifugal pump?

1. Increase in the efficiency of the pump.
2. Conversion of part of the pressure head to velocity head.
3. Giving uniform flow of the fluid coming out of the impeller.

Select the correct answer using the codes given below:

- (a) 1 and 2 (b) 1 and 3
(c) 2 and 3 (d) 1, 2 and 3 [ESE : 1998]

2.11 Consider the following data for the performance of a centrifugal pump:

Speed = 1200 rpm

Flow rate = 30 litres per second

Head = 20 m

Power = 5 kW

If the speed is increased to 1500 rpm, the power will be nearly equal to

- (a) 6.5 kW (b) 8.7 kW
(c) 9.8 kW (d) 10.9 kW [ESE : 1999]

2.12 Consider the following pumps:

1. Centrifugal pump, single-stage
2. Centrifugal pump, multi-stage
3. Reciprocating pump
4. Jet pump

The pump(s) which can be used to lift water through a suction head of 12 m from a well would include

- (a) 2 only (b) 1, 3 and 4
(c) 4 only (d) 1 and 3 [ESE : 1999]

2.13 Hydraulic ram is a pump which works on the principle of

- (a) water hammer
(b) centrifugal action
(c) reciprocating action
(d) hydraulic press [ESE : 1999]

■ ■ ■ ■

Answers Hydraulic Pumps

- 2.1 (b) 2.2 (a) 2.3 (d) 2.4 (a) 2.5 (b) 2.6 (b) 2.7 (a) 2.8 (d) 2.9 (b)
2.10 (b) 2.11 (c) 2.12 (c) 2.13 (a)

Explanations Hydraulic Pumps

2.1 (b)

The function of air-vessel are:

(1) On suction side

- (i) To reduce accelerating head. This will reduced the total vacuum head, reducing the possibility of separation and saving in power required for supplying accelerating head.
- (ii) Pump can be run on higher speed.
- (iii) Length of suction pipe below the air vessel can be increased.

(2) On delivery side

- (i) To reduce the accelerating head and affecting in large amount of power consumed in supplying the accelerating head.
- (ii) A uniform rate of discharge is ensured.

2.2 (a)

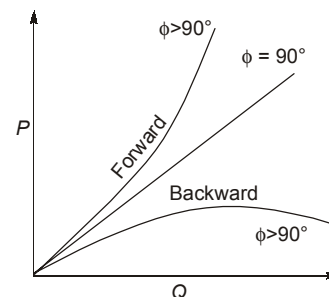

As shown in figure, in forward curved vanes head increases with the discharge. Hence with forward curves vanes ($\phi > 90^\circ$) power input rises sharply, with the discharge whereas in backward vanes ($\phi < 90^\circ$), the power input decreases steadily with the increases in discharge.

2.3 (d)

Cavitation occurs only under adverse pressure gradient. This is possible on suction side of a pump and exit side of turbine. The exit side of a pump has always positive pressure.

2.5 (b)

NPSH is defined as the head required to make the liquid to flow through the suction pipe to the impeller.

The *NPSH* should always be positive to keep away the cavitation.

2.6 (b)

A centrifugal pump can be started with its delivery valve fully closed.

2.8 (d)

Power = $\rho gQH = wHQ$ $\therefore w = \rho g$

2.9 (b)

$$N_s = \frac{N\sqrt{Q}}{H^{3/4}}$$

At same specific speed, the efficiency is greater with larger capacity.

2.10 (b)

In volute type of casing there is only a slight increase in the efficiency of the pump, because a considerable loss of energy takes place in eddies developed in the casing.

By diffuser action into volute casing converts most of kinetic energy the fluid discharged by impeller into pressure energy.

2.11 (c)

Condition-1

$$N_1 = 1200 \text{ rpm}; Q_1 = 300 \text{ litre/s};$$

$$H_1 = 20 \text{ m}; P_1 = 5 \text{ kW}$$

Condition-2

$$N_2 = 1500 \text{ rpm}; P_2 = ?$$

Power coefficient,

$$C_p = \frac{P}{\rho D^5 N^3}$$

$$(C_p)_1 = (C_p)_2$$

$$\frac{P_1}{\rho D^5 N_1^3} = \frac{P_2}{\rho D^5 N_2^3}$$

$$\frac{P_1}{N_1^3} = \frac{P_2}{N_2^3}$$

$$\frac{5}{(1200)^3} = \frac{P}{(1500)^3}$$

or $P_2 = 9.76 \text{ kW} \approx \mathbf{9.8 \text{ kW}}$

2.12 (c)

Since suction head is 12 m *i.e.* more than atmospheric pressure, only jet pump can be used to lift water under such situation.

2.13 (a)

The working of a hydraulic ram is based on the principle of water hammer or inertia pressure developed in the supply pipe .



3

Miscellaneous Hydraulic Machines

3.1 Assertion (A): No solid connection exists between the driving shaft and the driven shaft.

Reason (R): Energy transfer is by the change in moment of momentum.

- (a) Both **A** and **R** are individually true and **R** is the correct explanation of **A**
- (b) Both **A** and **R** are individually true but **R** is not the correct explanation of **A**
- (c) **A** is true but **R** is false
- (d) **A** is false but **R** is true [ESE : 1996]

3.2 Consider the following statements regarding torque converter:

1. It has a stationary set of blades in addition to the primary and secondary rotors.
2. It can be used for multiplication of torques.
3. The maximum efficiency of a converter is less than that of a fluid coupling.
4. In a converter designed to give a large increase of torque, the efficiency at smaller speed ratio approaches unity.

Which of these statements are correct?

- (a) 1, 2, 3 and 4
- (b) 1, 2 and 3
- (c) 1, 2 and 4
- (d) 3 and 4 [ESE : 1997]

3.3 In contrast to fluid couplings, torque converters are operated

- (a) while completely filled with liquid
- (b) while partially filled with liquid
- (c) without liquid
- (d) while completely filled with air [ESE : 1997]

3.4 Assertion (A): In a fluid coupling, hydrodynamic transmission is done by pump and turbine.

Reason (R): Fluid coupling is a type of machine in which fluid is used as a means of energy transfer.

- (a) Both **A** and **R** are individually true and **R** is the correct explanation of **A**
- (b) Both **A** and **R** are individually true but **R** is not the correct explanation of **A**
- (c) **A** is true but **R** is false
- (d) **A** is false but **R** is true [ESE : 1998]

3.5 If ω_s and ω_p represent the angular velocities of driven and driving members of a fluid coupling respectively, then the slip is equal to

- (a) $1 - \frac{\omega_s}{\omega_p}$
- (b) $\frac{\omega_s}{\omega_p}$
- (c) $\frac{\omega_p}{\omega_s}$
- (d) $1 - \frac{\omega_p}{\omega_s}$

[ESE : 1999]



Answers Miscellaneous Hydraulic Machines

3.1 (a) **3.2** (b) **3.3** (a) **3.4** (a) **3.5** (a)

Explanations Miscellaneous Hydraulic Machines

3.4 (b)

Fluid coupling is a device used for transmission of power through a liquid medium. A hydraulic (or fluid) coupling consists of a pump impeller which is attached to a driving shaft and a turbine runner attached to a driven shaft. These two units are enclosed in a single housing which contains a liquid, usually oil because of its lubricating power, availability and stability. No direct contact

exists between the driving parts and the driven parts. The oil in the housing transmits the moment of momentum or torque from the pump impeller to the turbine runner.

3.5 (a)

$$\begin{aligned} \text{Slip} &= 1 - \frac{\text{angular velocity of driven member}}{\text{angular velocity of driving member}} \\ &= 1 - \frac{\omega_s}{\omega_p} \end{aligned}$$



4

Air Compressors (Reciprocating and Rotary)

- 4.1 A large clearance volume in reciprocating compressor results in
- reduced volume flow rate
 - increased volume flow rate
 - lower suction pressure
 - lower delivery pressure

[ESE : 1995]

- 4.2 In a reciprocating air compressor the compression work per kg of air
- increases as clearance volume increases
 - decreases as clearance volume increases
 - is independent of clearance volume
 - increases with clearance volume only of multi-stage compressor

[ESE : 1995]

- 4.3 Consider the following statements:
When air is to be compressed to reasonably high pressure, it is usually carried out by multi-stage compressor with an intercooler between the stages because

- Work supplied is saved.
- Weight of compressor is reduced.
- More uniform torque is obtained leading to the reduction in the size of flywheel.
- Volumetric efficiency is increased.

Which of these statements is/are correct?

- 1 alone
- 2 and 4
- 1, 2 and 3
- 1, 2, 3 and 4

[ESE : 1995]

- 4.4 The inlet and exit velocity diagram of a turbomachine rotor are shown in the figure-I and figure-II respectively

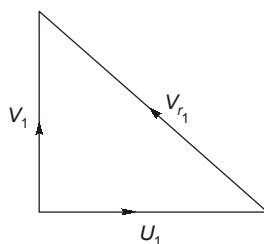

Fig. I

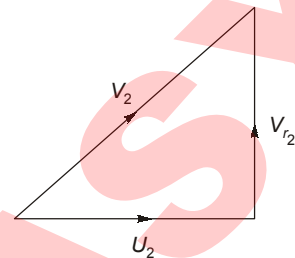

Fig. II

The turbomachine is

- an axial compressor with radial blades
- a radial compressor with radial blades
- a radial compressor with curved blades
- an axial compressor with forward curved blades

[ESE : 1995]

- 4.5 In a centrifugal compressor assuming the same overall dimensions, blade inlet angle and rotational speeds, which of the following bladings will be given the maximum pressure rise?

- Forward curved blades
- Backward curved blades
- Radial blades
- All three types of bladings have the same pressure rise

[ESE : 1995]

- 4.6 In a centrifugal compressor, the highest Mach number leading to shockwave in the fluid flow occurs at

- diffuser inlet radius
- diffuser outlet radius
- impeller inlet radius
- impeller outer radius

[ESE : 1995]

- 4.7 **Assertion (A):** The work required per kg of air flow/min. for axial flow compressor is lower than that of centrifugal compressor for the same pressure ratio.

Reason (R): The isentropic efficiency of axial flow compressor is much higher than that of a centrifugal compressor.

- (a) Both **A** and **R** are individually true and **R** is the correct explanation of **A**
 (b) Both **A** and **R** are individually true but **R** is not the correct explanation of **A**
 (c) **A** is true but **R** is false
 (d) **A** is false but **R** is true

[ESE : 1995]

- 4.8** The curve in the given figure shows the variation of theoretical pressure ratio with mass of flow rate for a compressor running at constant speed. The permissible operating range of the compressor is represented by the part of the curve from

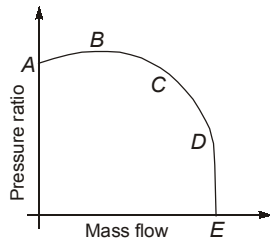

- (a) A to B (b) B to C
 (c) B to D (d) D to E

[ESE : 1995]

- 4.9** For a multi-stage compressor, the polytropic efficiency is
 (a) the efficiency of all stages combined together
 (b) the efficiency of one stage
 (c) constant throughout for all the stages
 (d) a direct consequence of the pressure ratio

[ESE : 1996]

- 4.10** Which one of the following is the effect of blade shape on performance of centrifugal compressor?
 (a) Backward curved blade has poor efficiency
 (b) Forward curved blade has higher efficiency
 (c) Backward curved blades lead to stable performance
 (d) Forward curved blades produce lower pressure ratio

[ESE : 1996]

- 4.11** Surging basically implies
 (a) Unsteady, periodic and reversed flow
 (b) Forward motion of air at a speed above sonic velocity

- (c) The surging action due to the blast of air produced in a compressor
 (d) Forward movement of aircraft

[ESE : 1996]

- 4.12** Degree of reaction in an axial compressor is defined as the ratio of static enthalpy rise in the
 (a) rotor to static enthalpy rise in the stator
 (b) stator to static enthalpy rise in the rotor
 (c) rotor to static enthalpy rise in the stage
 (d) stator to static enthalpy rise in the stage

[ESE : 1996]

- 4.13** The usual assumption in elementary compressor cascade theory is that
 (a) axial velocity through the cascade changes
 (b) for elementary compressor cascade theory, the pressure rise across the cascade is given by equation of state
 (c) axial velocity through the cascade does not change
 (d) with no change in axial velocity between inlet and outlet, the velocity diagram is formed

[ESE : 1996]

- 4.14** Consider the following statements :
 The volumetric efficiency of a compressor depends upon
 1. Clearance volume.
 2. Pressure ratio.
 3. Index of expansion.

Which of these statements are correct?

- (a) 1 and 2 (b) 1 and 3
 (c) 2 and 3 (d) 1, 2 and 3

[ESE : 1996]

- 4.15** Which one of the following type of compressor is mostly used for supercharging of I.C. engine
 (a) Radial flow compressor
 (b) Axial flow compressor
 (c) Root blower
 (d) Reciprocating compressor

[ESE : 1996]

- 4.16** Phenomenon of choking in compressor means
 (a) no flow of air
 (b) fixed mass flow rate regardless of pressure ratio
 (c) reducing mass flow rate with increases in pressure ratio
 (d) increased inclination of the chord with air stream

[ESE : 1996]

- 4.17 The heat rejection by a reciprocating air compressor during the reversible compression process AB , shown in the following temperature-entropy diagram, is represented by the area:

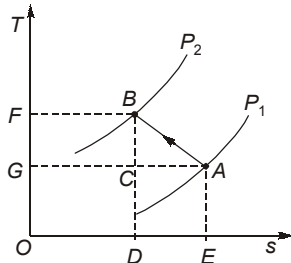

- (a) ABC (b) $ABDE$
(c) $ABFG$ (d) $ABFOE$

[ESE : 1997]

- 4.18 Centrifugal compressors are suitable for large discharge and wider mass flow range, but at a relatively low discharge pressure of the order of 10 bars, because of
- low pressure ratio
 - limitation of size of receiver
 - large speeds
 - high compression index

[ESE : 1997]

- 4.19 Given: V_{w_2} = velocity of whirl at outlet
 u_2 = peripheral velocity of the blade tips
The degree of reaction in a centrifugal compressor is equal to

- (a) $1 - \frac{V_{w_2}}{2u_2}$ (b) $1 - \frac{u_2}{2V_{w_2}}$
(c) $1 - \frac{2V_{w_2}}{u_2}$ (d) $1 - \frac{V_{w_2}}{u_2}$

[ESE : 1997]

- 4.20 **Assertion (A):** In axial flow compressors, momentum blading is more efficient than radial flow blading.

Reason (R): In radial flow blading, the pressure head increases due to centrifugal head.

- Both **A** and **R** are individually true and **R** is the correct explanation of **A**
- Both **A** and **R** are individually true but **R** is not the correct explanation of **A**
- A** is true but **R** is false
- A** is false but **R** is true

[ESE : 1997]

- 4.21 A four-stage compressor with perfect intercooling between stages, compresses air from 1 bar to 16 bar. The optimum pressure in the last intercooler will be

- (a) 6 bar (b) 8 bar
(c) 10 bar (d) 12 bar

[ESE : 1998]

- 4.22 In the centrifugal air compressor design practice, the value of polytropic exponent of compression is generally taken as

- (a) 1.2 (b) 1.3
(c) 1.4 (d) 1.5

[ESE : 1998]

- 4.23 The turbomachine used to circulate refrigerant in large refrigeration plant is

- A centrifugal compressor
- A radial turbine
- An axial compressor
- An axial turbine

[ESE : 1998]

- 4.24 The energy transfer process is

- Continuous in a reciprocating compressor and intermittent in an axial compressor
- Continuous in an axial compressor and intermittent in a reciprocating compressor
- Continuous in both reciprocating and axial compressors
- Intermittent in both reciprocating and axial compressors

[ESE : 1998]

- 4.25 In an axial flow compressor stage, air enters and leaves the stage axially. If the whirl component of the air leaving the rotor is half the mean peripheral velocity of the rotor blades, then the degree of reaction will be

- (a) 1 (b) 0.75
(c) 0.50 (d) 0.25

[ESE : 1998]

- 4.26 If an axial flow compressor is designed for constant velocity through all stages, then the area of annulus of the succeeding stages will

- Remain the same
- Progressively decrease
- Progressively increase
- Depend upon the number of stages

[ESE : 1998]

4.27 What will be the shape of the velocity triangle at the exit of a radial bladed centrifugal impeller, taking into account slip?

- (a) Right-angled
- (b) Isosceles
- (c) All angles less than 90°
- (d) One angle greater than 90°

[ESE : 1998]

4.28 Which one of the following statements is true?

- (a) In a multi-stage compressor, adiabatic efficiency is less than stage efficiency
- (b) In a multi-stage turbine, adiabatic efficiency is less than the stage efficiency
- (c) Reheat factor for a multi-stage compressor is greater than one
- (d) Reheat factor does not affect the multi-stage compressor performance

[ESE : 1998]

4.29 At the eye tip of a centrifugal impeller, blade velocity is 200 m/s while the uniform axial velocity at the inlet is 150 m/s. If the sonic velocity is 300 m/s. Then the inlet Mach number of the flow will be

- (a) 0.50
- (b) 0.66
- (c) 0.83
- (d) 0.87

[ESE : 1998]

4.30 Assertion (A): A reciprocating air compressor at sea level would deliver a greater mass of air than a compressor on a mountain.

Reason (R): The compressor ratings are given for "free air".

- (a) Both **A** and **R** are individually true and **R** is the correct explanation of **A**
- (b) Both **A** and **R** are individually true but **R** is not the correct explanation of **A**

(c) **A** is true but **R** is false(d) **A** is false but **R** is true

[ESE : 1998]

4.31 A three-stage reciprocating compressor has suction pressure of 1 bar delivery pressure of 27 bar. For minimum work of compression, the delivery pressure of first-stage is

(a) 14 bar

(b) 9 bar

(c) 5.196 bar

(d) 3 bar

[ESE : 1999]

4.32 Consider the following factors:

1. Cylinder size
2. Clearance ratio
3. Delivery pressure
4. Compressor shaft power

The factors which affect the volumetric efficiency of a single-stage reciprocating air compressor would include

(a) 1 and 2

(b) 3 and 4

(c) 2 and 3

(d) 1 and 4

[ESE : 1999]

4.33 In centrifugal compressor terminology, vaneless space refers to the space between

- (a) The inlet and blade inlet edge
- (b) Blades in the impeller
- (c) Diffuser exit and volute casing
- (d) Impeller tip and diffuser inlet edge

[ESE : 1999]

4.34 If the static temperature rise in the rotor and stator respectively are ΔT_A and ΔT_B , the degree of reaction in an axial flow compressor is given by

(a) $\frac{\Delta T_A}{\Delta T_B}$ (b) $\frac{\Delta T_A}{\Delta T_A + \Delta T_B}$ (c) $\frac{\Delta T_B}{\Delta T_A + \Delta T_B}$ (d) $\frac{\Delta T_B}{\Delta T_A}$

[ESE : 1999]

■■■■

Answers Air Compressors (Reciprocating & Rotary)

- 4.1 (a) 4.2 (c) 4.3 (d) 4.4 (b) 4.5 (a) 4.6 (c) 4.7 (a) 4.8 (c) 4.9 (c)
 4.10 (c) 4.11 (a) 4.12 (c) 4.13 (b) 4.14 (d) 4.15 (c) 4.16 (b) 4.17 (b) 4.18 (a)
 4.19 (a) 4.20 (b) 4.21 (b) 4.22 (c) 4.23 (a) 4.24 (b) 4.25 (b) 4.26 (b) 4.27 (c)
 4.28 (a) 4.29 (c) 4.30 (b) 4.31 (d) 4.32 (c) 4.33 (d) 4.34 (b)

Explanations Air Compressors (Reciprocating & Rotary)**4.1 (a)**

The clearance volume is the space between piston top and inner surface of the cylinder head. The clearance volume reduces the capacity of the compressor and volume flow rate.

4.2 (c)

The compressor work depends upon the actual volume of the air entering the compressor and not the clearance volume. If the actual volume entering to the compressor is same with clearance and without clearance volume, then the compression work will be same.

4.3 (d)

Advantage of multi-stage compression over single stage compression:

1. The workdone per kg of air is reduced in multi-stage compression with intercooler as compared to single stage compression for the same delivery pressure.
2. It improves the volumetric efficiency for the given pressure ratio.
3. The size of the two cylinder (i.e. high pressure and low pressure) may be adjusted to suit the volume and pressure of the air.
4. It reduce the leakage loss considerably.
5. It gives more uniform torques and hence a smaller size flywheel is required.
6. It provides effective lubrication because of lower temperature range.
7. It reduces the cost of compressor.

4.5 (a)

Backward curved blades are slightly better in efficiency and are stable over a wide range of flow. While forward curved blades are used for higher pressure ratio.

4.6 (c)

At the impeller inlet radius, the air is deflected through a certain angle before it passes into the radial channel on the impeller vane. If the Mach number at this point exceeds unity, shock wave may be formed. The shock wave causes a rapid increases in the losses.

4.7 (a)

Isentropic efficiency of axial compressor = 85-88%
Isentropic efficiency of centrifugal compressor equal to 70%

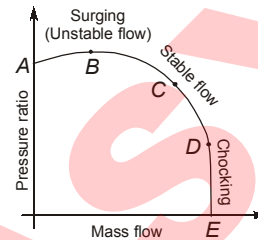
4.8 (c)

Hence B-D represents stable operation of compressor.

4.9 (c)

Polytropic efficiency is a small-stage efficiency and is defined as the isentropic efficiency of an elemental stage of the compression which is constant throughout the whole process.

4.10 (c)

Backward curved blades are slightly better in efficiency and are stable over a wide range of flow. While forward curved blades are used for higher pressure ratio.

4.11 (a)

Surging: When the delivery valve of compressor is just opened, there will be positive pressure gradient and as a result of that there will be back flow of air. Due to pulsating nature of flow, air gets heated up. This is an unstable condition of flow and called surging.

4.12 (c)

$$D.R. = \frac{\text{Enthalpy rise in rotor}}{\text{Enthalpy rise in the stage}}$$

4.14 (d)

$$\text{Volumetric efficiency} = 1 + C - C \left(\frac{p_2}{p_1} \right)^{1/n}$$

where, C = clearance volume ratio

n = index of expansion

p_2/p_1 = Pressure ratio

4.15 (c)

As reciprocating compressors are bulky. They are not used except for stationary installation and radial and axial flow compressor are not suitable due to problem of surging and high speed required for operation.

Root blower is suitable for supercharging of IC engine.

4.16 (b)

In choking flow rate is maximum and pressure ratio is minimum.

4.17 (b)

Heat interaction is given by the area under the T-s curve.

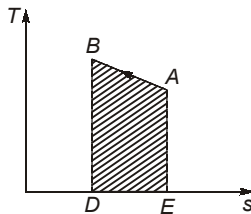

Heat rejection, $\delta Q = \text{Area ABDE}$

4.18 (a)

Centrifugal compressor have pressure ratio of around 5 : 1 and suitable for high mass flow rates.

4.19 (a)

Degree of reaction

$$R = \frac{\text{Pressure rise in the rotor}}{\text{Pressure rise in the stage}}$$

$$R = \frac{(u_1^2 - u_2^2) + (V_2^2 - V_1^2)}{(V_1^2 - V_2^2) + (u_1^2 - u_2^2) + (V_2^2 - V_1^2)}$$

For centrifugal compressor; no whirl at inlet or radial discharge and constant velocity of flow

$$R = \left(1 - \frac{V_{w2}}{2u_2}\right)$$

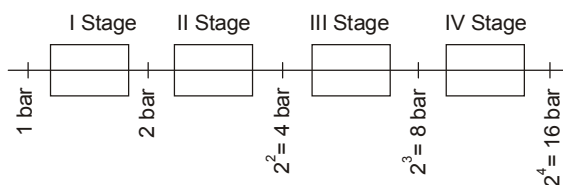
4.21 (b)

Hence intermediate pressure in the last intercooler in 8 bar.

4.23 (a)

Large amount of vapour refrigerant at low pressure is required to handle in large refrigerant plant. Also unlike reciprocating compressor, centrifugal compressor is steady-flow device hence subjected to less vibration and noise.

4.24 (b)

Axial compressor is steady-flow compressor, thus energy transfer process is continuous process.

4.25 (b)

$$D.R. = 1 - \frac{V_{w2}}{2u_2} = 1 - \frac{1}{4} = \frac{3}{4} \quad \left(V_{w2} = \frac{u_2}{2}\right)$$

4.26 (b)

$\dot{m} = \rho AV_f = \text{Constant}$
with succeeding stage, density increases and for velocity to be kept constant, area should be decreased.

4.28 (a)

Polytropic or stage efficiency is greater than adiabatic efficiency.

Polytropic or small stage efficiency

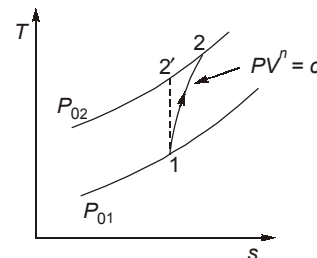

$$\eta = \frac{T'_{02} - T_{01}}{T_{02} - T_{01}} = \frac{\frac{T'_{02}}{T_{01}} - 1}{\frac{T_{02}}{T_{01}} - 1}$$

$$\text{Since } \frac{T'_{02}}{T_{01}} = \left(\frac{P_{02}}{P_{01}}\right)^{\frac{k-1}{k}} \text{ and}$$

$$\frac{T_{02}}{T_{01}} = \left(\frac{P_{02}}{P_{01}}\right)^{\frac{n-1}{n}}$$

$$\therefore \eta = \frac{\left(\frac{P_{02}}{P_{01}}\right)^{\frac{k-1}{k}} - 1}{\left(\frac{P_{02}}{P_{01}}\right)^{\frac{n-1}{n}} - 1} = \frac{\left(\frac{P_{01} + \Delta P_0}{P_{01}}\right)^{\frac{k-1}{k}} - 1}{\left(\frac{P_{01} + \Delta P_0}{P_{01}}\right)^{\frac{n-1}{n}} - 1}$$

$$= \frac{\left(1 + \frac{\Delta P_0}{P_{01}}\right)^{\frac{k-1}{k}} - 1}{\left(1 + \frac{\Delta P_0}{P_{01}}\right)^{\frac{n-1}{n}} - 1}$$

Expanding binomially and neglecting higher order

$$\eta = \frac{\frac{k-1}{k} \cdot \frac{\Delta P_0}{P_{01}}}{\frac{n-1}{n} \cdot \frac{\Delta P_0}{P_{01}}} = \left(\frac{k-1}{k}\right) \left(\frac{n}{n-1}\right)$$

4.29 (c)

Velocity of air relative to the vane

$$V_{r1} = \sqrt{u^2 + V_f^2}$$

$$= \sqrt{(200)^2 + (150)^2} = 250 \text{ m/s}$$

$$\text{Mach number: } M = \frac{V}{C} = \mathbf{0.833}$$

4.30 (b)

At sea level the density of air is higher.

4.31 (d)

Overall pressure ratio

$$= (\text{pressure ratio in each stage})^N$$

where N is number of stage

$$\frac{27}{1} = \left(\frac{P_2}{P_1}\right)^3$$

Pressure ratio in each stage

$$\frac{P_2}{P_1} = (27)^{1/3} = 3$$

Delivery pressure of first stage is

$$= P_2 = 3P_1 = 3 \times 1 = \mathbf{3 \text{ bar}}$$

4.32 (c)

Volumetric efficiency (η_v)

$$= 1 - \left(\frac{V_C}{V_S}\right) \left[\left(\frac{P_2}{P_1}\right)^{1/n} - 1 \right]$$

$$= 1 + C - C \left(\frac{P_2}{P_1}\right)^{1/n}$$

Hence volumetric efficiency depends upon clearance ratio and pressure ratio.

4.34 (b)

$$D.R. = \frac{\text{Enthalpy drop in rotor}}{\text{Total enthalpy drop in the stage}}$$

$$= \frac{c_p \Delta T_A}{c_p \Delta T_A + c_p \Delta T_B} = \frac{\Delta T_A}{\Delta T_A + \Delta T_B}$$

■■■■

- 5.1 The degree of reaction of a turbine is defined as the ratio of
- static pressure drop to total energy transfer
 - total energy transfer to static pressure drop
 - change of velocity energy across the turbine to the total energy transfer
 - velocity energy to pressure energy

[ESE : 1995]

- 5.2 Among other things, the poor part-load performance of De Laval turbines is due to the
- formation of shock waves in the nozzle
 - formation of expansion waves at the nozzle
 - turbulent mixing at the nozzle exit
 - increased profile losses in the rotor

[ESE : 1995]

- 5.3 Match **List-I** (Various velocities in the velocity diagram of a two-stage impulse turbine) with **List-II** (Blade angles) and select the correct answer using the codes given below the lists:

List-I

- Relative velocity of steam at inlet tip of blade
- Absolute velocity of steam at inlet tip of blade
- Relative velocity of steam at outlet tip of blade
- Absolute velocity of steam at outlet tip of blade

List-II

- Nozzle angle
- Moving blade leading edge angle
- Moving blade trailing edge angle
- Fixed blade leading edge angle

Codes:

	A	B	C	D
(a)	1	2	4	3
(b)	2	1	4	3
(c)	2	1	3	4
(d)	1	2	3	4

[ESE : 1995]

- 5.4 The graph given in the figure represents the variation of absolute velocity of steam along the length of a steam turbine.

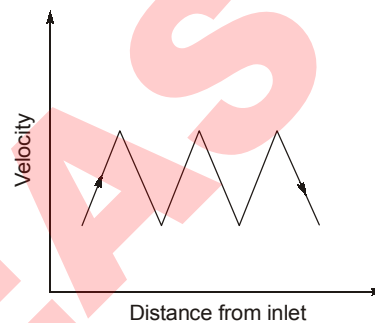

The turbine in question is

- Curtis turbine
- De Laval turbine
- Radial turbine
- Parson's turbine

[ESE : 1995]

- 5.5 The correct sequence of the given steam turbines in the ascending order of efficiency at their design points is

- Rateau, De Laval, Parson's, Curtis
- Curtis, De Laval, Rateau, Parson's
- De Laval, Curtis, Rateau, Parson's
- Parson's Curtis, Rateau, De Laval

[ESE : 1995]

- 5.6 Which one of the following relationship between angles of fixed blades and moving blades corresponds to that of Parson's turbine

- $\alpha_1 = \alpha_2$
- $\alpha_1 = \beta_2$
- $\alpha_2 = \beta_2$
- $\beta_1 = \beta_2$

[ESE : 1995]

- 5.7 The following data refers to an axial flow turbine stage:

Relative velocity of steam at inlet to the rotor = 79.0 m/s, Relative velocity at the rotor exit = 152 m/s. The approximate degree of reaction is

- 0.9
- 0.8
- 0.7
- 0.6

[ESE : 1995]

- 5.8 The clearance flow between the blade tips and casing of a steam turbine is
- greater in the reaction turbine than in the impulse type
 - greater in the impulse turbine than in the reaction type
 - independent of type of the turbine
 - independent of the size of the turbine

[ESE : 1995]

- 5.9 The lines abc and cd in the given graph are known as

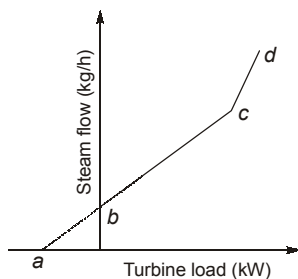

- Wilson's line
- Willan's line
- S.C. line
- Throttling line

[ESE : 1995]

- 5.10 Consider the following statements regarding the nozzle governing of steam turbines:
- Working nozzles receive steam at full pressure.
 - High efficiency is maintained at all loads.
 - Stage efficiency suffers due to partial admission.
 - In practice each nozzle of the first stage is governed individually.

Which of these statements are correct?

- 1, 2 and 3
- 1 and 2
- 1, 3 and 4
- 1, 2 and 4

[ESE : 1995]

- 5.11 Ratio of actual indicated work to hypothetical indicated work in a steam engine is the
- Indicated thermal efficiency
 - Friction factor
 - Mechanical efficiency
 - Diagram factor

[ESE : 1996]

- 5.12 Running speeds of steam turbine can be brought down to practical limits by which of the following method (s)?
- By using heavy flywheel.
 - By using a quick response governor.

- By compounding.
 - By reducing fuel feed to the furnace.
- 3 alone
 - 1, 2, 3 and 4
 - 1, 2 and 4
 - 2 and 3

[ESE : 1996]

Direction: Each of the next questions consists of two statements, one labelled as the 'Assertion (A)' and the other as 'Reason (R)'. You are to examine these two statements carefully and select the answers to these items using the codes given below:

Codes:

- Both **A** and **R** are individually true and **R** is the correct explanation of **A**
- Both **A** and **R** are individually true but **R** is not the correct explanation of **A**
- A** is true but **R** is false
- A** is false but **R** is true

- 5.13 **Assertion (A):** The speed of governed turbine is constant irrespective of load

Reasons (R): In governing, the steam supply is regulated to maintain the speed

[ESE : 1996]

- 5.14 **Assertion (A):** In the case of reaction turbines for power plant applications, a large number of stages is common in practice

Reasons (R): A pressure drop takes place in the moving blade in a reaction turbine unlike an impulse turbine, where pressure remains constant across the moving blade.

[ESE : 1996]

- 5.15 The net result of pressure-velocity compounding of steam turbine is:

- Less number of stages
- Large turbine for a given pressure drop
- Shorter turbine for a given pressure drop
- Lower friction loss

[ESE : 1997]

- 5.16 Given V_b = Blade speed

V = Absolute velocity of steam entering the blade

α = Nozzle angle

The efficiency of an impulse turbine is maximum when

- $V_b = 0.5 V \cos \alpha$
- $V_b = V \cos \alpha$
- $V_b = 0.5 V^2 \cos \alpha$
- $V_b = V^2 \cos \alpha$

[ESE : 1997]

5.17 An impulse turbine produces 50 kW of power when the blade mean speed is 400 m/s. The rate of change of momentum tangential to the rotor is
 (a) 200 N (b) 175 N
 (c) 150 N (d) 125 N [ESE : 1997]

5.18 At a particular section of a reaction turbine, the diameter of the blade is 1.8 m, the velocity of flow of steam is 49 m/s and the quantity of steam flow is 5.4 m³/s. The blade height at this section will be approximately:
 (a) 4 cm (b) 2 cm
 (c) 1 cm (d) 0.5 cm [ESE : 1997]

5.19 Consider the following statements:
 If steam is reheated during the expansion through turbine stages

1. Erosion of blade will decrease.
2. The overall pressure ratio will increase.
3. The total heat drop will increase.

Which of these statements are correct?
 (a) 1, 2 and 3 (b) 1 and 2
 (c) 2 and 3 (d) 1 and 3 [ESE : 1997]

5.20 In a Rankine cycle, with the maximum steam temperature being fixed from metallurgical consideration, as the boiler pressure increases
 (a) the condenser load will increase
 (b) the quality of turbine exhaust will decrease
 (c) the quality of turbine exhaust will increase
 (d) the quality of turbine exhaust will remain unchanged
 [ESE : 1997]

Direction: Each of the next questions consists of two statements, one labelled as the '**Assertion (A)**' and the other as '**Reason (R)**'. You are to examine these two statements carefully and select the answers to these items using the codes given below:

Codes:

- Both **A** and **R** are individually true and **R** is the correct explanation of **A**
- Both **A** and **R** are individually true but **R** is not the correct explanation of **A**
- A** is true but **R** is false
- A** is false but **R** is true

5.21 Assertion (A): The work done in Parson's reaction turbine is twice the work done during expansion in the moving blades.

Reason (R): The steam expands both in the moving as well as in the fixed blades in a reaction turbine and in the Parson's turbine, the fixed and moving blades are identical.
 [ESE : 1997]

5.22 Assertion (A): The purpose of employing reheat in a steam power plant is mainly to improve its thermal efficiency.

Reason (R): The use of regeneration in a steam power plant improves the efficiency.
 [ESE : 1998]

5.23 Assertion (A): Reaction turbines are not built on pure reaction principle.

Reason (R): Pure reaction is difficult to realize in practice.
 [ESE : 1998]

5.24 Assertion (A): Work output per stage of an impulse turbine is double that of a 50% reaction stage at the same speed.

Reason (R): Maximum speed ratio is limited for any class of turbine.
 [ESE : 1998]

5.25 In an impulse-reaction turbine stage, the heat drop in fixed and moving blades are 15 kJ/kg and 30 kJ/kg respectively. The degree of reaction for this stage will be

- 1/3 (b) 1/2
- 2/3 (d) 3/4

[ESE : 1998]

5.26 If D is the diameter of the turbine wheel and U is its peripheral velocity, then the disc friction loss will be proportional to

- $(DU)^3$ (b) $D^2 U^3$
- $D^3 U^2$ (d) DU^4

[ESE : 1998]

5.27 The compounding of steam turbines is done to

- Improve efficiency
- Reduce turbine speed
- Increase blade speed ratio
- Reduce axial thrust

[ESE : 1999]

5.28 Match List-I (Different turbine stages) with List-II (Turbines) and select the correct answer using the codes given below the lists:

List-I

- 50% reaction stage
- Two-stage velocity compounded turbine

- C. Single-stage impulse
D. Two-stage pressure compounded turbine

List-II

1. Rateau
2. Parson
3. Curtis
4. De-Laval
5. Hero

Codes:

	A	B	C	D
(a)	5	1	2	3
(b)	5	3	2	1
(c)	2	3	4	1
(d)	3	1	4	2

[ESE : 1999]

- 5.29** The expression for the maximum efficiency of a Parson's turbine is (α is the angle made by absolute velocity at inlet)

(a) $\frac{\cos^2 \alpha}{2(1 + \cos^2 \alpha)}$ (b) $\frac{2 + \cos^2 \alpha}{2\cos^2 \alpha}$
 (c) $\frac{2\cos \alpha}{1 + \cos^2 \alpha}$ (d) $\frac{2\cos^2 \alpha}{1 + \cos^2 \alpha}$

[ESE : 1999]

- 5.30** Consider the following statements regarding effects of re-heating of steam in a steam turbine:

1. It increases the specific output of the turbine.
2. It decreases the cycle efficiency.
3. It increases blade erosion.
4. It improves the quality of exit steam.

Which of these statements are correct?

- (a) 1 and 2 (b) 2 and 3
(c) 3 and 4 (d) 1 and 4 [ESE : 1999]

- 5.31** Consider the following statements:

The efficiency of the vapour power Rankine cycle can be increased by

1. Increasing the temperature of the working fluid at which heat is added.

2. Increasing the pressure of the working fluid at which heat is added.
3. Decreasing the temperature of the working fluid at which heat is rejected.

Which of these statements is/are correct?

- (a) 2 and 3 (b) 1 only
(c) 1 and 2 (d) 1, 2 and 3

[ESE : 1999]

- 5.32** Consider the following processes :

1. Constant pressure heat addition
2. Adiabatic compression
3. Adiabatic expansion
4. Constant pressure heat rejection

The correct sequence of these processes in Rankine cycle is:

- (a) 1, 2, 3, 4 (b) 2, 1, 4, 3
(c) 2, 1, 3, 4 (d) 1, 2, 4, 3

[ESE : 1999]

- 5.33** The reheat cycle in steam power plant is mainly adopted to

- (a) Improve thermal efficiency
- (b) Decrease the moisture content in low pressure stages to a safe value
- (c) Decrease the capacity of condenser
- (d) Recover the waste heat of boiler

[ESE : 1999]

- 5.34 Assertion (A):** Parson turbine has a degree of reaction equal to 50%.

Reason (R): It is a reaction turbine with symmetrical fixed and moving blades.

- (a) Both **A** and **R** are individually true and **R** is the correct explanation of **A**
- (b) Both **A** and **R** are individually true but **R** is not the correct explanation of **A**
- (c) **A** is true but **R** is false
- (d) **A** is false but **R** is true

[ESE : 1999]

**Answers Steam Turbine**

- 5.1 (c) 5.2 (a) 5.3 (c) 5.4 (d) 5.5 (b) 5.6 (b) 5.7 (d) 5.8 (a) 5.9 (b)
 5.10 (a) 5.11 (d) 5.12 (a) 5.13 (c) 5.14 (b) 5.15 (b) 5.16 (a) 5.17 (d) 5.18 (b)
 5.19 (d) 5.20 (b) 5.21 (a) 5.22 (d) 5.23 (a) 5.24 (b) 5.25 (c) 5.26 (c) 5.27 (b)
 5.28 (c) 5.29 (d) 5.30 (d) 5.31 (d) 5.32 (c) 5.33 (b) 5.34 (a)

Answers Steam Turbine

- 5.1 (c) 5.2 (a) 5.3 (c) 5.4 (d) 5.5 (b) 5.6 (b) 5.7 (d) 5.8 (a) 5.9 (b)
 5.10 (a) 5.11 (d) 5.12 (a) 5.13 (c) 5.14 (b) 5.15 (b) 5.16 (a) 5.17 (d) 5.18 (b)
 5.19 (d) 5.20 (b) 5.21 (a) 5.22 (d) 5.23 (a) 5.24 (b) 5.25 (c) 5.26 (c) 5.27 (b)
 5.28 (c) 5.29 (d) 5.30 (d) 5.31 (d) 5.32 (c) 5.33 (b) 5.34 (a)

Explanations Steam Turbine

5.1 (c)

$$R = \frac{(\Delta H)_{\text{isentropic (Blade)}}}{(\Delta H)_{\text{isen. (nozzle)}} + (\Delta H)_{\text{isen. (Blade)}}$$

We know that

$$(\Delta H)_{\text{isen. (nozzle)}} = \frac{C_1^2 - \phi C_2^2}{2\eta_n} \text{ kJ/kg}$$

$$(\Delta H)_{\text{isen. (Blade)}} = \frac{C_{r2}^2 - \phi C_{r1}^2}{2\eta_b} \text{ kJ/kg}$$

where, C_1 and C_2 is absolute velocity for nozzle

C_{r2} and C_{r1} is relative velocity of blade

ϕ = carry-over efficiency

5.2 (a)

Due to increase in back pressure a shock is formed in divergent nozzle.

5.3 (c)

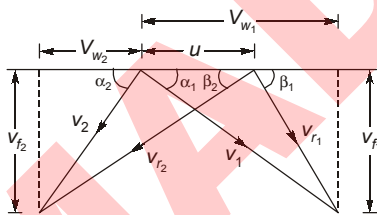

- where α_1 = Nozzle angle
- β_1 = Moving blade leading edge angle
- β_2 = Moving blade trailing edge angle
- α_2 = Fixed blade leading edge angle

5.4 (d)

In Parson reaction turbine

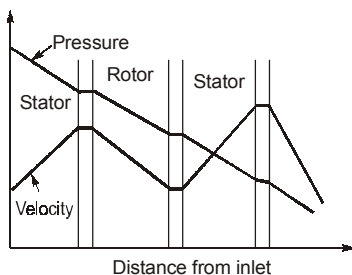

5.5 (b)

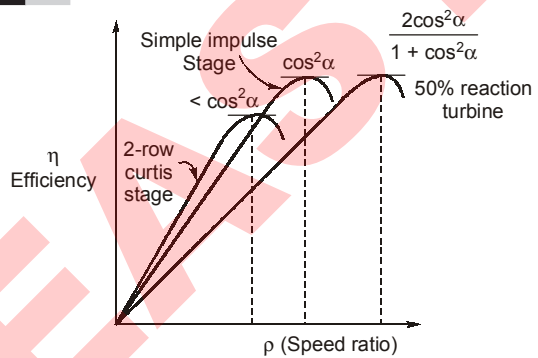

5.6 (b)

For Parson's turbine :

$$\alpha_1 = \beta_2$$

$$\alpha_2 = \beta_1$$

5.8 (a)

The leakage loss between the blade tips and the casing, is greater in reaction turbine than in impulse turbine due to the pressure difference across the clearance passage.

5.9. (b)

The general relation of Willians' line is,
 $S = S_0 + kP$
 where S_0 is the steam consumption when the turbine is giving zero output. S is the steam consumption when the turbine is developing the power P and k is a constant.

5.10 (a)

Nozzle control governing is more efficient method of governing compared with throttle governing specially at part loads. The principle of nozzle control governing is that according to the load on the turbine the steam supply is varied by means of nozzle.

The nozzles are made up in sets, each set being controlled by a separate valve.

5.11 (d)

Diagram factor

$$= \frac{\text{Area of actual indicator diagram}}{\text{Area of hypothetical indicator diagram}}$$

5.12 (a)

By compounding the steam in large number of stages, running speeds of steam turbine is brought down so that it can match the synchronous speed of generator.

5.13 (c)

Governing is done by nozzle and in throttle governing steam supply is not regulated.

5.15 (b)

As we do compounding, a large number of stages are required for an optimum speed.

5.16 (a)

For maximum efficiency of impulse turbine

$$\frac{u}{V_1} = \frac{\cos \alpha_1}{2}$$

$$u = 0.5 V_1 \cos \alpha_1$$

5.17 (d)

Power = $F \times V$

$$\therefore F = \frac{50 \times 1000}{400} = 125 \text{ N}$$

5.18 (b)

$$Q = AV_f = (\pi Dh)V_f$$

$$5.4 = (\pi \times 1.8 \times h)49$$

$$h = 0.02 \text{ m} = \mathbf{2 \text{ cm}}$$

5.19 (d)

The overall pressure ratio will be constant in reheating.

5.20 (b)

As the boiler pressure increases, quality of the steam at the exit of the turbine decreases.

5.21 (a)

In Parson's reaction turbine, both fixed and moving blades are identical, work done by fixed and moving blades are equal. Due to this, total workdone is equal to the twice the work done by moving blades or fixed blades.

5.22 (d)

The purpose of employing reheat in a steam power plant is mainly to improve quality of steam at the exit of the turbine and net work output of the turbine.

5.25 (c)

$$D.R. = \frac{\text{Enthalpy drop in moving blade}}{\text{Total enthalpy drop in the stage}}$$

$$= \frac{30}{30+15} = \frac{2}{3}$$

5.27 (b)

Steam expanding from modern boiler pressure of 170 bar and 500°C temperature to the condenser pressure 0.1 bar, will have velocity of about 1654 m/s meaning a blade speed of 820 m/s. Such a speed is far beyond the maximum allowable safety limit because this value of velocity used in small machine would give high speeds of rotation of the order of 30000 rev/min. High rotational speed means high stresses. To overcome these difficulties impulse turbine is compounded for pressure and velocity.

5.28 (c)

Single stage impulse turbine or pure impulse turbine is known as De-lavel turbine and 50% reaction turbine is known as Parson's reaction turbine. Pressure compounded impulse turbine is known as Rateau staging and velocity compounded impulse turbine is known as Curtis staging.

5.29 (d)

Maximum efficiency of Parson's turbine is

$$\eta_{\max} = \frac{2 \cos^2 \alpha}{1 + \cos^2 \alpha}$$

5.30 (d)

Reheating increases the work ratio and increases specific work output and decreases the effect of components losses, it also improves the quality of exit steam.

5.31 (d)

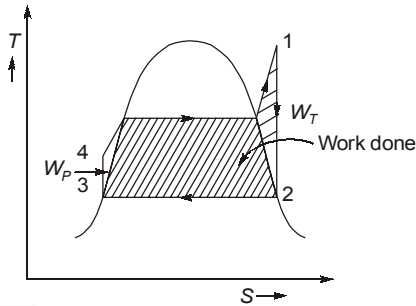

5.32 (c)

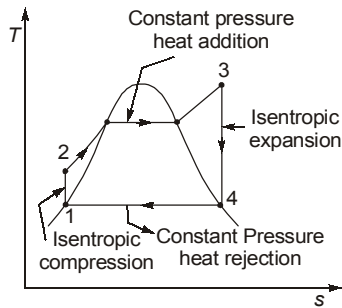

5.33 (b)

Reheat is employed to improve dryness fraction.

5.34 (a)

Fixed and moving blades are symmetrical in Parson turbine.

∴ exit angle of moving blade
= exit angle of fixed blade and
inlet angle of fixed blade
= inlet angle of moving blade

∴ Parson turbine has a degree of reaction equal to 50%

■■■■

MADE EAS

6

Gas Turbines

6.1 Consider the following statements with reference to gas turbine cycle

1. Regeneration increases thermal efficiency.
2. Reheating decreases thermal efficiency.
3. Cycle efficiency increases when maximum temperature of the cycle is increased.

Which of these statements are correct?

- (a) 1, 2 and 3 (b) 2 and 3
(c) 1 and 2 (d) 1 and 3

[ESE : 1995]

6.2 The given figure shows four plots *A*, *B*, *C* and *D* of thermal efficiency against pressure ratio

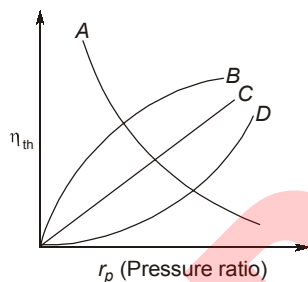

The curve which represents that of a gas turbine plant using Brayton (without regeneration) is the one labelled

- (a) *A* (b) *B*
(c) *C* (d) *D*

[ESE : 1995]

Direction: Each of the next questions consists of two statements, one labelled as the '**Assertion (A)**' and the other as '**Reason (R)**'. You are to examine these two statements carefully and select the answers to these items using the codes given below:

Codes:

- (a) Both **A** and **R** are individually true and **R** is the correct explanation of **A**
- (b) Both **A** and **R** are individually true but **R** is not the correct explanation of **A**
- (c) **A** is true but **R** is false
- (d) **A** is false but **R** is true

6.3 Assertion (A): The thermal efficiency of gas turbine plants is higher compared to diesel plants.

Reason (R): The mechanical efficiency of gas turbines is higher compared to diesel engines.

[ESE : 1995]

6.4 Assertion (A): Gas turbines use very high air fuel ratio.

Reasons (R): The allowable maximum temperature at the turbine inlet is limited by available material considerations.

[ESE : 1995]

6.5 Assertion (A): In a gas turbine, reheating is preferred over regeneration to yield a higher thermal efficiency.

Reasons (R): The thermal efficiency given by the ratio of the difference of work done by turbine (W_t) and work required by compressor (W_c) to heat added (Q_A) is improved by increasing the W_t keeping W_c and Q_A constant in reheating, whereas in regeneration Q_A is reduced keeping W_t and W_c constant.

[ESE : 1996]

6.6 The optimum intermediate pressure p_i for a gas turbine plant operating between pressure limits p_1 and p_2 with perfect undercooling between the two stages of compression (with identical isentropic efficiency) is given by

- (a) $p_i = p_2 - p_1$
(b) $p_i = \frac{1}{2} (p_1 + p_2)$
(c) $p_i = \sqrt{p_1 p_2}$
(d) $p_i = \sqrt{p_2^2 + p_1^2}$

[ESE : 1996]

6.7 In a gas turbine cycle, the turbine output is 600 kJ/kg, the compressor work is 400 kJ/kg and the heat supplied is 1000 kJ/kg. The thermal efficiency of this cycle is:

- (a) 80% (b) 60%
(c) 40% (d) 20%

[ESE : 1997]

- 6.8 In a single-stage open-cycle gas turbine, the mass flow through the turbine is higher than the mass flow through compressor, because
- the specific volume of air increases by use of intercooler
 - the temperature of air increases in the reheater
 - the combustion of fuel takes place in the combustion chamber
 - the specific heats at constant pressure for incoming air and exhaust gases are different

[ESE : 1997]

- 6.9 The given figure shows the effect of the substitution of an isothermal compression process for the isentropic compression process on the gas turbine cycle. The shaded area (1-5-2-1) in the p-V diagram represents:

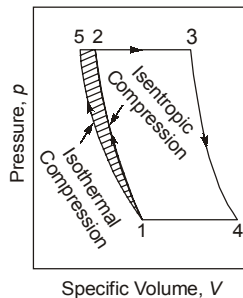

- reduction in the compression work
- reduction in the specific volume
- increment in the compression work
- increment in the specific volume

[ESE : 1997]

- 6.10 A gas turbine develops 120 kJ of work while the compressor absorbed 60 kJ of work and the heat supplied is 200 kJ. If a regenerator which would recover 40% of the heat in the exhaust were used, then the increase in the overall thermal efficiency would be:
- 10.2%
 - 8.6%
 - 6.9%
 - 5.7%

[ESE : 1997]

- 6.11 Which one of the thermodynamic cycles shown in the following figures represents that of Brayton cycle?

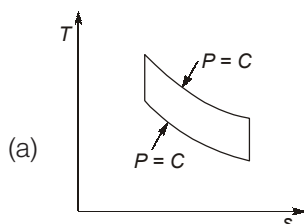

(a)

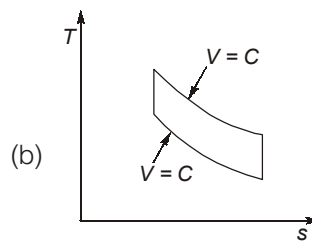

(b)

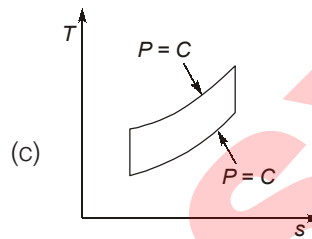

(c)

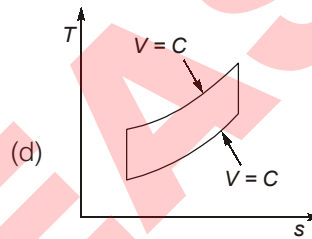

(d)

[ESE : 1997]

Direction: Each of the next questions consists of two statements, one labelled as the 'Assertion (A)' and the other as 'Reason (R)'. You are to examine these two statements carefully and select the answers to these items using the codes given below:

Codes:

- Both **A** and **R** are individually true and **R** is the correct explanation of **A**
- Both **A** and **R** are individually true but **R** is not the correct explanation of **A**
- A** is true but **R** is false
- A** is false but **R** is true

6.12 **Assertion (A):** The thermal efficiency of a gas turbine plant is low as compared to that of reciprocating IC engines.

Reason (R): In a gas turbine plant, the maximum pressure and temperature are low when compared to those of reciprocating IC engines.

[ESE : 1997]

6.13 **Assertion (A):** In gas turbines, regenerative heating always improves the efficiency unlike that in the case of reheating.

Reason (R): Regenerative heating is isentropic.

[ESE : 1998]

6.14 A gas turbine works on which one of the following cycles?

- (a) Brayton (b) Rankine
(c) Stirling (d) Otto

[ESE : 1998]

6.15 Reheating in a gas turbine

- (a) Increases the compressor work
(b) Decreases the compressor work
(c) Increase the turbine work
(d) Decreases the turbine work

[ESE : 1998]

6.16 Consider the following statements relating to a closed gas turbine cycle:

1. The cycle can employ mono-atomic gas like helium instead of air to increase the cycle efficiency if other conditions are the same.
2. The efficiency of heat exchanger increases with the use of helium.
3. The turbine blades suffer higher corrosion damages.
4. Higher output can be obtained for the same size.

Which of these statements are correct?

- (a) 1, 2 and 3 (b) 1, 2 and 4
(c) 2, 3 and 4 (d) 1, 3 and 4

[ESE : 1999]

Direction: Each of the next questions consists of two statements, one labelled as the '**Assertion (A)**' and the other as '**Reason (R)**'. You are to examine these two statements carefully and select the answers to these items using the codes given below:

Codes:

- (a) Both **A** and **R** are individually true and **R** is the correct explanation of **A**
(b) Both **A** and **R** are individually true but **R** is not the correct explanation of **A**
(c) **A** is true but **R** is false
(d) **A** is false but **R** is true

6.17 Assertion (A): The thermal efficiency of Brayton cycle with regeneration decreases as the compressor ratio increases.

Reason (R): As the compression ratio of compressors increases, the range of temperature in the regenerator decreases and the amount of heat recovered reduces.

[ESE : 1999]



Answers Gas Turbines

- 6.1 (a) 6.2 (b) 6.3 (d) 6.4 (b) 6.5 (d) 6.6 (c) 6.7 (d) 6.8 (c) 6.9 (a)
 6.10 (a) 6.11 (c) 6.12 (b) 6.13 (c) 6.14 (a) 6.15 (c) 6.16 (b) 6.17 (a)

Explanations Gas Turbines**6.2 (b)**

For gas turbine plant using Brayton cycle.

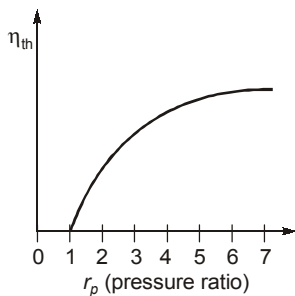
**6.4 (b)**

Basically air to fuel-ratio is high for gas turbine to create cooling medium in the combustion chamber.

6.5 (d)

Reheating yields thermal efficiency only when it is conjunction with a heat exchanger, i.e a regenerator although it does not improve the work-output.

6.7 (d)

$$\begin{aligned} \text{Net work} &= \text{Turbine work} - \text{Compression work} \\ &= 600 - 400 = 200 \text{ kJ/kg} \end{aligned}$$

$$\begin{aligned} \text{Thermal efficiency} &= \frac{\text{Net work}}{\text{Heat added}} \times 100 \\ &= \frac{200}{1000} \times 100 = \mathbf{20\%} \end{aligned}$$

6.8 (c)

After the compression of air, same amount of fuel is added in the combustion chamber which undergoes combustion. After combustion the flue gases are expanded in the turbine which is more than the mass flow rate of only air in the compressor.

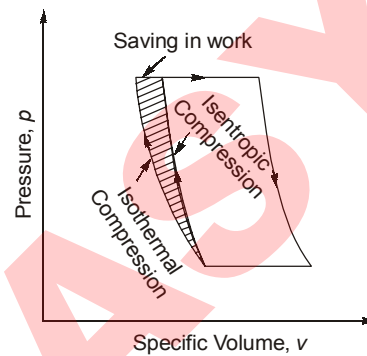
6.9 (a)

By compressing the air isothermally, less work input is required as compared to isentropic compression. Hence the area between these two process represents the saving in the work.

6.10 (a)

Case-I: Simple cycle

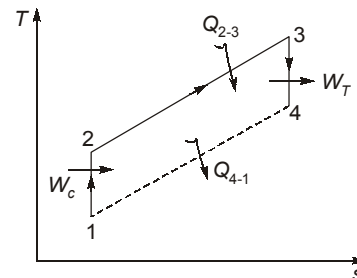

$$W_T = 120 \text{ kJ}; \quad W_c = 60 \text{ kJ}$$

$$Q_{2-3} = 200 \text{ kJ}$$

$$\begin{aligned} \eta_{\text{Th}} &= \frac{W_T - W_c}{Q_{2-3}} = \frac{120 - 60}{200} \\ &= 0.30 = 30\% \end{aligned}$$

$$\text{Heat rejected, } Q_{4-1} = Q_{2-3} - (W_T - W_c)$$

$$= 200 - (120 - 60) = 140 \text{ kJ}$$

Case-II: Cycle with regeneration

Heat recovered:

$$\begin{aligned} Q_{2-3} &= 40\% \text{ of } Q_{4-1} \\ &= 0.40 \times 140 = 56 \text{ kJ} \end{aligned}$$

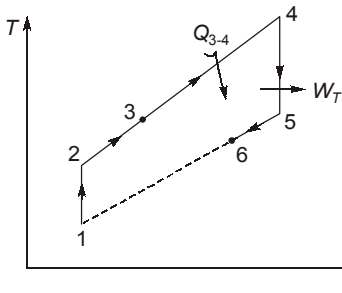

Heat supplied:

$$Q_{3-4} = 200 - 56 = 144 \text{ kJ}$$

$$\eta_{Th}' = \frac{W_T - W_c}{Q_{2-3}} = \frac{120 - 60}{144} = 0.4166 = 41.66\%$$

Increase in efficiency

$$\eta_{Th}' - \eta_{Th} = 41.66 - 30 = 11.66\%$$

6.11 (c)

Brayton cycle consists of two reversible isobaric and two reversible adiabatic processes.

6.13 (c)

In gas turbine regeneration improves the efficiency due to less heat supplied for the same output.

The regeneration is done at constant pressure.

6.15 (c)

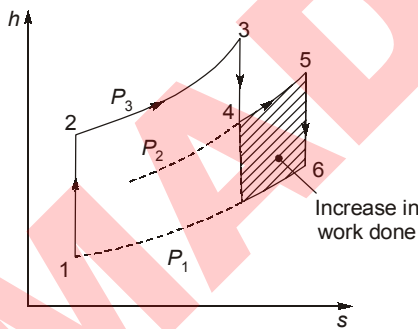

6.16 (b)

Advantages of closed cycle gas turbine

- (1) It is possible to use a gas having more favorable properties than air. cycle efficiency depends upon γ so gases having high value of γ can be used like helium ($\gamma = 1.67$). Helium has the further attraction of a much higher thermal conductivity than air resulting in the use of small heat exchanger.
- (2) A cycle operates with a limited amount of clean fluid (air). The compressor and turbine blades are free from deposits of dirt and dust.
- (3) More output with higher thermal efficiency.
- (4) Any type of fuel can be used such as coal, oil, gas, nuclear, solar or stored energy.

6.17 (a)

The efficiency of Brayton cycle with regeneration

$$= 1 - \frac{T_{min}}{T_{max}} (r_p)^{\frac{\gamma-1}{\gamma}}$$

where r_p = Compression ratio

for fixed $\frac{T_{min}}{T_{max}}$ the cycle efficiency decreases with increase in compressor ratio.



- 7.1 Consider the following statements:
As compared to turbo-prop, a turbo-jet
1. can operate at higher attitudes.
 2. can operate at higher flight velocities.
 3. is more fuel efficient at lower speeds.

Which of these statements are correct?

- (a) 1, 2 and 3 (b) 1 and 2
(c) 2 and 3 (d) 1 and 3

[ESE : 1995]

- 7.2 Propulsion efficiency of a jet engine is given by (where u is flight velocity and V is jet velocity relative to aircraft).

- (a) $\frac{2u}{V-u}$ (b) $\frac{V+u}{2u}$
(c) $\frac{2u}{V+u}$ (d) $\frac{V-u}{2u}$

[ESE : 1995]

- 7.3 Under which one of the following sets of conditions will a supersonic compressor have the highest efficiency?

- (a) Rotor inlet velocity is supersonic and exit velocity subsonic; stator inlet velocity is subsonic and exit velocity is subsonic
(b) Rotor inlet velocity is supersonic and exit velocity subsonic; stator inlet velocity is supersonic and exit velocity is subsonic
(c) Rotor inlet velocity is supersonic and exit velocity supersonic; stator inlet is supersonic and exit velocity is subsonic.
(d) Rotor inlet velocity is supersonic and exit velocity supersonic; stator inlet velocity is subsonic and exit velocity is subsonic.

[ESE : 1995]

- 7.4 The critical value of Mach number for a subsonic airfoil is associated with sharp increase in drag due to local shock formation and its interaction with the boundary layer. A typical value of this critical Mach number is of the order of

- (a) 0.4 to 0.5 (b) 0.75 to 0.85
(c) 1.1 to 1.3 (d) 1.5 to 2.0

[ESE : 1995]

- 7.5 A supersonic aircraft is ascending at an angle of 30° to the horizontal. When an observer at the ground hears its sound, the aircraft is seen at an elevation of 60° to the horizontal. The flight Mach number of the aircraft is

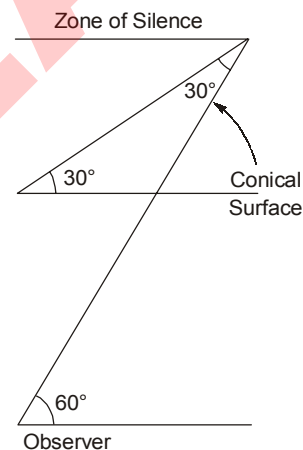

- (a) $2/\sqrt{3}$ (b) $\sqrt{3}/2$
(c) $1/2$ (d) 2

[ESE : 1995]

- 7.6 **Assertion (A):** In the subsonic range the propulsive efficiency of a rocket is less than that of a turbo-jet

Reason (R): The jet velocity of rocket is independent of forward motion.

- (a) Both **A** and **R** are individually true and **R** is the correct explanation of **A**
(b) Both **A** and **R** are individually true but **R** is not the correct explanation of **A**
(c) **A** is true but **R** is false
(d) **A** is false but **R** is true

[ESE : 1995]

7.7 Consider the following statements:

In open cycle turbo-jet engines used in military aircraft, reheating the exhaust gas from the turbine by burning more fuel is used to increase

1. Thrust.
2. The efficiency of engine.
3. The range of aircraft.

Which of these statements are correct?

- (a) 1 and 3 (b) 1 and 2
(c) 2 and 3 (d) 1, 2 and 3

[ESE : 1996]

7.8 In a turbo-jet engine, subsequent to heat addition to compressed air, to get the power output, the working substance is expanded in

- (a) turbine blades, which is essentially an isentropic process
- (b) turbine blades, which is polytropic process
- (c) exit nozzle, which is essentially in isentropic process
- (d) exit nozzle, which is a constant volume process

[ESE : 1996]

7.9 Consider the following statements relating to rocket engines:

1. The combustion chamber in a rocket engine is directly analogous to the reservoir of a supersonic wind tunnel.
2. Stagnation conditions exist at the combustion chamber.
3. The exit velocities of exhaust gases are much higher than those in jet engines.
4. Efficiency of rocket engines is higher than that of jet engines.

Which of these statements are correct?

- (a) 1, 3 and 4 (b) 2, 3 and 4
(c) 1, 2 and 3 (d) 1, 2 and 4

[ESE : 1996]

7.10 Only rocket engines can be propelled to space because

- (a) they can generate very high thrust
- (b) they have high propulsion efficiency
- (c) these engines can work on several fuels
- (d) they are not air-breathing engines.

[ESE : 1996]

7.11 Consider the following statements :

Across the normal shock, the fluid properties change in such a manner that the

1. Velocity of flow is subsonic.
2. Pressure increases.

3. Specific volume decreases.

4. Temperature decreases.

Which of these statements are correct?

- (a) 2, 3 and 4 (b) 1, 2 and 4
(c) 1, 3 and 4 (d) 1, 2 and 3

[ESE : 1996]

7.12 For oblique shock, the downstream Mach number

- (a) is always more than unity
- (b) is always less than unity
- (c) may be less or more than unity
- (d) can never be unity

[ESE : 1997]

7.13 Consider the following statements about a rocket engine:

1. It is a very simple in construction and operation.
2. It can attain very high vehicle velocity.
3. It can operate for very long duration.

Which of these statements are correct?

- (a) 1 and 3 (b) 1 and 2
(c) 2 and 3 (d) 1, 2 and 3

[ESE : 1997]

7.14 Fanno line flow is a flow in a constant area duct

- (a) with friction and heat transfer
- (b) with friction and heat transfer and accompanied by work
- (c) with friction but in the absence heat transfer or work
- (d) without friction but accompanied by heat transfer and work

[ESE : 1997]

7.15 Rayleigh line flow is a flow in a constant area duct

- (a) with friction but without heat transfer
- (b) without friction but with heat transfer
- (c) with both friction and heat transfer
- (d) without either friction or heat transfer

[ESE : 1997]

Direction: Each of the next questions consists of two statements, one labelled as the 'Assertion (A)' and the other as 'Reason (R)'. You are to examine these two statements carefully and select the answers to these items using the codes given below:

Codes:

- (a) Both **A** and **R** are individually true and **R** is the correct explanation of **A**
- (b) Both **A** and **R** are individually true but **R** is not the correct explanation of **A**
- (c) **A** is true but **R** is false
- (d) **A** is false but **R** is true

7.16 Assertion (A): Compared to a turbo-jet engine, a turbo-prop engine has a higher power for take-off and higher propulsive efficiency at low speeds.

Reason (R): By mounting the propeller on the turbine shaft, the propeller can be run at a very high speed to obtain higher efficiency.

[ESE : 1997]

7.17 Assertion (A): In the case of Fanno line flow, in the subsonic region friction causes irreversible acceleration.

Reason (R): In the case of Fanno line flow, decrease in entropy is not possible either for supersonic or subsonic flows.

[ESE : 1997]

7.18 The prime parameter causing change of state in a Fanno flow is

- (a) Heat transfer (b) Area change
(c) Friction (d) Buoyancy

[ESE : 1998]

7.19 In a normal shock in a gas, the

- (a) upstream flow is supersonic
(b) upstream flow is subsonic
(c) downstream flow is sonic
(d) both downstream flow and upstream flow are supersonic

[ESE : 1998]

7.20 Which one of the following is the correct sequence of the position of the given components in a Turbo-prop?

- (a) Propeller, Compressor, Turbine, Burner
(b) Compressor, Propeller, Burner, Turbine
(c) Propeller, Compressor, Burner, Turbine
(d) Compressor, Propeller, Turbine, Burner

[ESE : 1998]

7.21 Consider the following statements:

The thrust of rocket engine depends upon

1. Effective jet velocity.
2. Weight of the rocket.
3. Rate of propellant consumption.

Which of these statements are correct?

- (a) 1 and 2 (b) 1 and 3
(c) 2 and 3 (d) 1, 2 and 3

[ESE : 1998]

7.22 Consider the following statements:

In a turbo-jet engine, thrust may be increased by

1. Increasing the jet velocity.

2. Increasing the mass flow rate of air.
3. After burning of the fuel.

Which of these statements are correct?

- (a) 1 and 2 (b) 2 and 3
(c) 1 and 3 (d) 1, 2 and 3

[ESE : 1998]

7.23 The effective jet exit velocity from a rocket is 2700 m/s. The forward flight velocity is 1350 m/s. The propulsive efficiency of the unit is

- (a) 200% (b) 100%
(c) 66.666% (d) 33.333%

[ESE : 1998]

Direction: Each of the next questions consists of two statements, one labelled as the '**Assertion (A)**' and the other as '**Reason (R)**'. You are to examine these two statements carefully and select the answers to these items using the codes given below:

Codes:

- (a) Both **A** and **R** are individually true and **R** is the correct explanation of **A**
(b) Both **A** and **R** are individually true but **R** is not the correct explanation of **A**
(c) **A** is true but **R** is false
(d) **A** is false but **R** is true

7.24 Assertion (A): Propulsion efficiency of propeller driven aircraft is low at very high speeds.

Reason (R): At high speeds, shock waves are formed over propeller blades. [ESE : 1998]

7.25 Assertion (A): A bypass jet engine gives a better propulsive efficiency and better fuel economy than a straight jet engine.

Reason (R): A bypass jet engine gives lower velocity of jet efflux than a straight jet engine.

[ESE : 1998]

7.26 Which of the following pairs of engine and performance/characteristic is/are correctly matched ?

1. Turbo-jet : Efficiency increases with flight speed
2. SI engine : Lowest specific fuel consumption
3. Turbo-prop : Suitable for low flight speeds

Select the correct answer using the codes given below:

- (a) 1 and 2 (b) 2 and 3
(c) 1 and 3 (d) 2 alone [ESE : 1998]

7.27 An aircraft flying horizontally at a speed of 900 km/hr is propelled by a jet leaving the nozzle at a speed of 500 m/s. The propulsive efficiency is

- (a) 0.334 (b) 0.426
(c) 0.556 (d) 0.667 [ESE : 1999]

7.28 Which one of the following is the correct statement?

- (a) The Mach number is less than 1 at a point where the entropy is maximum whether it is Rayleigh or Fannoline
(b) A normal shock can appear in subsonic flow
(c) The downstream Mach number across a normal shock is more than one
(d) The stagnation pressure across a normal shock decreases [ESE : 1999]

7.29 Air at 2 bar 60°C enters a constant area pipe of 60 mm diameter with a velocity of 40 m/s. During the flow through the pipe, heat is added to the air stream. Frictional effects are negligible and the values of C_p and C_v are that of standard air. The Mach number of the flow corresponding to the maximum entropy will be

- (a) 0.845 (b) 1
(c) 0.1212 (d) 1.183 [ESE : 1999]

7.30 Mach angle α and Mach number M are related as:

- (a) $M = \sin^{-1}\left(\frac{1}{\alpha}\right)$
(b) $\alpha = \cos^{-1}\left(\sqrt{\frac{M^2 - 1}{M}}\right)$
(c) $\tan \alpha = \left(\sqrt{M^2 - 1}\right)$
(d) $\alpha = \operatorname{cosec}^{-1}\left(\frac{1}{M}\right)$ [ESE : 1999]

7.31 Assertion (A): The use of turbo-prop engine is limited to medium speed applications.

Reason (R): The efficiency of a turbo-prop engine decreases at higher speed.

- (a) Both A and R are individually true and R is the correct explanation of A
(b) Both A and R are individually true but R is not the correct explanation of A
(c) A is true but R is false
(d) A is false but R is true [ESE : 1999]

■■■■

Answers Jet Propulsion and Compressible Flow

- 7.1 (b) 7.2 (c) 7.3 (d) 7.4 (b) 7.5 (a) 7.6 (b) 7.7 (b) 7.8 (b) 7.9 (c)
7.10 (d) 7.11 (d) 7.12 (c) 7.13 (d) 7.14 (c) 7.15 (b) 7.16 (a) 7.17 (b) 7.18 (c)
7.19 (a) 7.20 (c) 7.21 (b) 7.22 (d) 7.23 (c) 7.24 (a) 7.25 (a) 7.26 (c) 7.27 (d)
7.28 (d) 7.29 (b) 7.30 (b) 7.31 (a)

Explanations Jet Propulsion and Compressible Flow

7.1 (b)

As shown in graph at the higher altitudes and higher flight velocity turbojet has higher efficiency than turboprop and after a particular value of flight velocity, efficiency of turboprop decreases.

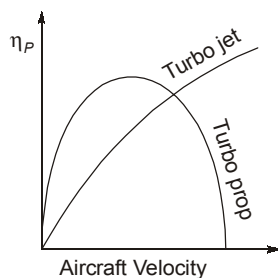

7.2 (c)

The propulsive efficiency (η_p) is defined as the thrust work divided by the rate at which work is done on the air in the aircraft.

$$\therefore \eta_p = \frac{2u(V-u)}{V^2 - u^2} = \frac{2u}{V+u}$$

7.4 (b)

Transonic drag rise graph:

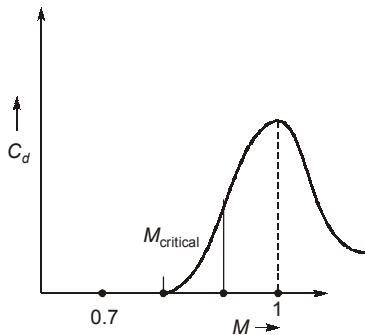
**7.5 (a)**

$$\alpha = \sin^{-1} \left(\frac{1}{M} \right)$$

$$\sin 60^\circ = \frac{1}{M}$$

$$\therefore M = \frac{2}{\sqrt{3}}$$

7.6 (b)

Rocket propulsive efficiency

$$= \frac{2C_j C_a}{C_j^2 + C_a^2} = \frac{2(C_a/C_j)}{1 + (C_a/C_j)^2}$$

where

C_a = Rocket velocity

C_j = Nozzle Velocity

It is interesting to note that as the case of jet propulsion efficiency of rocket approaches 100%

as $\frac{C_j}{C_a}$ approaches unity where as for the propeller and turbojet the flight velocity exceed the jet velocity if the thrust is to be positive. For the rocket the jet velocity is independent of forward motion the C_j can be less than, equal to or greater than C_a .

7.7 (b)

Turbojets are mainly used in military as fighters, bombers, and for transport application. They fly with supersonic speed. For e.g. MIGs, Mirage, Knat, Jaguar etc. The only turbojet used for civil aviation is concord.

Reheating the exhaust gas from the turbine by burning more fuel raises the exit temperature with

result in an increases velocity which increases the thrust and efficiency of engine.

7.8 (b)

The surrounding air at velocity equal to the plane speed enters the inlet section which is designed as a diffuser. The air is slowed down and part of kinetic energy of the air stream is converted into the pressure. This type of compression is called 'ram compression'. Further compression is achieved in a rotary compressor, which is usually an axial flow type. The pressurized air then flows into the combustion chamber where fuel is added. This raises temperature rapidly due to combustion of fuel, which occurs at constant pressure. The hot combustion products then enter the gas turbine where they undergo a limited expansion through polytropic process. The turbine is designed to produce power, which is just sufficient to drive the compressor, fuel pump and other auxiliaries. The exhaust from the turbine is at pressure considerably higher than the atmospheric pressure. These are then expanded in the exit nozzle and results in conversion of energy of hot gas into kinetic energy. The gases emerge from the exit with a higher velocity. Due to increase in velocity i.e. momentum of gases flowing through the exit, a reaction or thrust in opposite direction is produced and this propels the aircraft.

7.9 (c)

Efficiency of rocket engine is less than the jet engines.

7.10 (d)

A rocket propulsion device differs from other thermal jet engines in that its propellant carries both the fuel and the oxidizing agents. As a result, this type of the engine is independent of the atmospheric oxygen therefore it can operate at very high altitude and even in vacuum.

7.11 (d)

Across the normal shock, the fluid properties change which are

1. Stagnation temperature remains constant.
2. Stagnation pressure increases.
3. Static pressure increases.
4. Static temperature increases.
5. Velocity decreases
6. Density of the fluid increases.

7.12 (c)

For oblique shock, down stream Mach number may be less or greater than unity.
for $M > 1$, the weak shock
 $M < 1$, strong shock

7.13 (d)

Rocket engine is very simple in construction and operation. It consists of an injection system, a combustion chamber and an exit nozzle. The oxidizer and fuel is burnt in the combustion chamber producing a high pressure. The gases are ejected to atmosphere at very high velocity (supersonic velocity) through the nozzle.

7.14 (c)

Fanno line flow is characterised as the flow in a constant area duct with friction and without any heat and mass transfer.

7.15 (b)

Rayleigh line flow is characterised as the flow in a constant area duct without friction and with heat transfer.

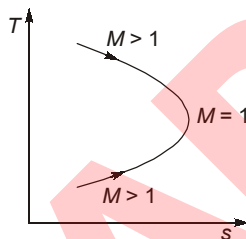
7.17 (b)

In supersonic region, fluid accelerates along with friction.

Statement (II) is correct as in both subsonic and supersonic region, entropy increases.

7.18 (c)

Fanno line flow is characterised as the flow in a constant area duct with friction and without any heat and mass transfer.

7.19 (a)

Normal shock appears only when the upstream flow is supersonic and after normal shock it becomes subsonic.

7.20 (c)

Prop-Gear-Box-Compressor-Combustion-Chamber-Turbine-Exhaust.

7.21 (b)

Sometimes the thrust is expressed in terms of mass flow rate of propellants and effective jet velocity:

$$\text{Thrust } T = \dot{m}_P C_{je}$$

The effective jet velocity is a hypothetical velocity and it is expressed as

$$C_{je} = C_j + \frac{A_j}{\dot{m}_P} (P_j - P_0) \text{ m/s}$$

where,

C_j = Exit or jet velocity relative to Nozzle

A_j = Exit area

\dot{m}_P = Mass flow rate of propellant

P_j = Exit static pressure

P_0 = Atmospheric pressure

7.22 (d)

Net thrust = Momentum thrust + Pressure thrust

$$T_{\text{net}} = \dot{m}_a (C_{je} - C_a) + A_j (P_j - P_a)$$

C_j = Velocity of jet relative to exit Nozzle

C_a = Vehicle velocity through the air

\dot{m}_a = Mass of air (kg/s)

A_j = Jet exit area

P_j = Exit pressure

P_a = Atmospheric pressure

Thrust can be increased by increasing mass flow rate and jet velocity.

After burning is done to improve the take-off and high speed performance of an aeroplane and flight at supersoni

7.23 (c)

Propulsive efficiency

$$= \frac{2 \times \text{Forward velocity of aircraft}}{\text{Forward velocity} + \text{Jet velocity}}$$

$$= \frac{2 \times 1350}{1350 + 2700} \times 100 = \mathbf{66.66\%}$$

7.24 (a)

The formation of shock waves over the blade section at high speed and blade slip at high altitude are the main drawbacks which limit the efficiency of the propeller. Now a day propeller driven aircraft is used only at low speed application i.e. upto 600 km/hr.

7.25 (a)

Turbofan or bypass jet engines at lower jet velocities give better propulsive efficiency and fuel economy compared with a turbojet engine for a given thrust as less kinetic energy is wasted to atmosphere.

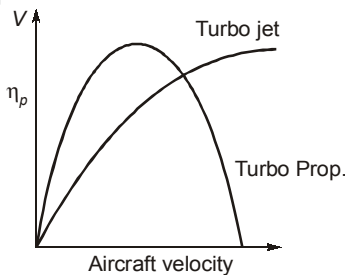
7.26 (c)**7.27 (d)**

Velocity of aircraft = 900 km/hr = 250 m/s

$$\text{Propulsive efficiency} = \frac{2 \times 250}{500 + 250} = 0.667$$

7.28 (d)

The Mach number is equal to 1 at a point where the entropy is maximum whether it is Rayleigh or Fanno line.

Normal shock wave can appear in supersonic flow ($M > 1$)

The stagnation temperature remains constant regardless of the strength of the shock. However that the stagnation pressure decreases across the shock because of irreversibility.

7.29 (b)

Due to heat transfer and negligible frictional effects, the flow is characterised as Rayleigh flow and in Rayleigh flow Mach number at maximum entropy is unity.

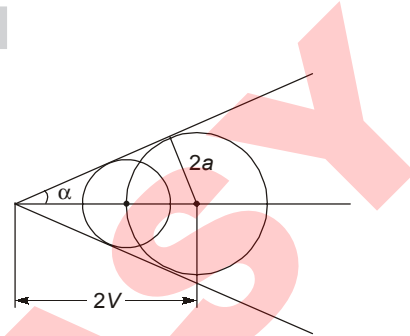
7.30 (b)

$$\sin \alpha = \frac{2a}{2V} = \frac{a}{V}$$

$$\sin \alpha = \frac{1}{M}$$

$$\sin^2 \alpha + \cos^2 \alpha = 1$$

$$\cos^2 \alpha = 1 - \frac{1}{M^2}$$

$$\cos^2 \alpha = \frac{M^2 - 1}{M^2}$$

$$\cos \alpha = \frac{\sqrt{M^2 - 1}}{M}$$

$$\alpha = \cos^{-1} \left\{ \frac{\sqrt{M^2 - 1}}{M} \right\}$$

$$M = \frac{V}{a}$$

7.31 (a)

The turboprop is limited at speeds below 800 km/hr because at higher speed its efficiency decreases.

■■■■

UNIT

VII

Power Plant Engineering

Syllabus

Rankine and Brayton cycles with regeneration and reheat, Fuels and their properties, Flue gas analysis, Boilers, steam turbines and other power plant components like condensers, air ejectors, electrostatic precipitators and cooling towers – their theory and design, types and applications, Compressors.

Contents

Sl.	Topic	Page No.
1.	Thermal Power Plant Components	154
2.	Nozzles	160
3.	Nuclear Power Plant	164
4.	Miscellaneous	167

○○○○

1

Thermal Power Plant Components

1.1 Match **List-I** (Type of boiler) with **List-II** (Classification of boiler) select the correct answer using the codes given below the lists:

List-I

- A. Babcock and Wilcox
- B. Lancashire
- C. La-mont
- D. Cochran

List-II

- 1. Forced circulation
- 2. Fire tube
- 3. Water tube
- 4. Vertical

Codes:

	A	B	C	D
(a)	1	2	3	4
(b)	2	3	4	1
(c)	3	2	1	4
(d)	2	4	1	3

[ESE : 1995]

1.2 Consider the following statements:

- 1. Boiler mountings are mainly protective devices.
- 2. Steam stop valve is an accessory.
- 3. Feed water pump is an accessory.

Which of these statements are correct?

- (a) 1, 2 and 3
- (b) 1 and 2
- (c) 2 and 3
- (d) 3 and 1

[ESE : 1995]

1.3 Match **List-I** with **List-II** select the correct answer using the codes given below the lists:

List-I

- A. Soot blower
- B. Electrostatic precipitator
- C. Blow down
- D. Zeolite

List-II

- 1. Removal of solids from boiler drums

- 2. To clean the tube surfaces of fly ash
- 3. Cleaning of flue gases
- 4. Air cleaning
- 5. Water purification

Codes:

	A	B	C	D
(a)	2	4	3	5
(b)	1	3	2	5
(c)	3	2	1	4
(d)	2	3	1	5

[ESE : 1995]

1.4 **Assertion (A):** All boilers used in power plants necessarily use forced circulation.

Reason (R): Forced circulation increases heat transfer.

- (a) Both **A** and **R** are individually true and **R** is the correct explanation of **A**
- (b) Both **A** and **R** are individually true but **R** is not the correct explanation of **A**
- (c) **A** is true but **R** is false
- (d) **A** is false but **R** is true

[ESE : 1995]

1.5 Which of the following is boiler mounting?

- (a) air pre-heater
- (b) economizer
- (c) fusible plug
- (d) steam trap

[ESE : 1996]

1.6 In forced circulation boilers, about 90% of water is recirculated without evaporation. The circulation ratio is

- (a) 0.1
- (b) 0.9
- (c) 9
- (d) 10

[ESE : 1996]

1.7 Given that, h is draught in mm of water, H is chimney height in meters, T_1 is atmospheric temperature in K, the maximum discharge of gases through a chimney is given by

- (a) $h = 176.5 T_1/H$
- (b) $h = H/176.5 T_1$
- (c) $h = 1.765 H/T_1$
- (d) $h = 176.5 H/T_1$

[ESE : 1996]

1.8 The excess air required for combustion of pulverized coal is of the order of

- (a) 100 to 150% (b) 30 to 60%
(c) 15 to 40% (d) 5 to 10%

[ESE : 1996]

1.9 Consider the following

1. Increasing evaporation rate using convection heat transfer from hot gases.
2. Increasing evaporation rate using radiation.
3. Protecting the refractory walls of the furnace.
4. Increasing water circulation rate.

The main reasons for providing water wall enclosure in high pressure boiler furnaces would include

- (a) 2 and 3 (b) 1 and 3
(c) 1 and 2 (d) 1, 2, 3 and 4

[ESE : 1996]

1.10 Consider the following statements :

Expansion joints in steam pipelines are installed to

1. Allow for future expansion of plant.
2. Take stresses away from flanges and fittings.
3. Permit expansion of pipes due to temperature rise.

Which of these statements are correct?

- (a) 1, 2 and 3 (b) 1 and 2
(c) 2 and 3 (d) 1 and 3

[ESE : 1996]

1.11 In a surface condenser used in a steam power station, undercooling of condensate is undesirable as this would

- (a) not absorb the gases in steam
(b) reduce efficiency of the plant
(c) increase the cooling water requirements
(d) increase thermal stresses in the condenser

[ESE : 1996]

1.12 Of all power plants, hydel is more disadvantageous when one compares the

- (a) nearness to load centre
(b) cost of energy resource
(c) technical skill required
(d) economics that determine the choice of plant

[ESE : 1996]

1.13 In thermal power plants, the deaerator is used mainly to

- (a) remove air form condenser
(b) increase feedwater temperature
(c) reduce steam pressure
(d) remove dissolved gases from feed water

[ESE : 1996]

1.14 Induced draught fans of a large steam generator have

- (a) backward curved blades
(b) forward curved blades
(c) straight or radial blades
(d) double curved blades

[ESE : 1996]

1.15 **Assertion (A):** The efficiency of a boiler is more if it is provided with mechanical draught rather than with natural draught

Reason (R): The exhaust gases can be cooled to the lowest possible temperature if mechanical draught is provided.

- (a) Both **A** and **R** are individually true and **R** is the correct explanation of **A**
(b) Both **A** and **R** are individually true but **R** is not the correct explanation of **A**
(c) **A** is true but **R** is false
(d) **A** is false but **R** is true

[ESE : 1996]

1.16 In High pressure natural circulation boilers the flue gases flow through the following boiler accessories:

1. Superheater 2. Air-preheater
3. Economizer 4. I.D. fan

The correct sequence of the flow of flue gases through these boiler accessories is:

- (a) 1, 3, 4, 2 (b) 3, 1, 4, 2
(c) 3, 1, 2, 4 (d) 1, 3, 2, 4

[ESE : 1997]

1.17 Consider the following components:

1. Radiation evaporator.
2. Economizers.
3. Radiation superheater.
4. Convection superheater.

In the case of Benson boiler, the correct sequence of the entry of water through these components is

- (a) 1, 2, 3, 4 (b) 1, 2, 4, 3
(c) 2, 1, 3, 4 (d) 2, 1, 4, 3

[ESE : 1997]

- 1.18 Coal fired power plant boilers manufactured in India generally use:
- pulverized fuel combustion
 - fluidized bed combustion
 - circulating fluidized bed combustion
 - moving stoker firing system [ESE : 1997]

- 1.19 Which of the following form part (s) of boiler mountings?

- Economiser
- Feed check valve
- Steam trap
- Superheater

Select the correct answer using the codes given below:

Codes:

- 2 alone
- 1 and 3
- 2, 3 and 4
- 1, 2, 3 and 4

[ESE : 1998]

- 1.20 Which of the following power plants use heat recovery boilers (unfired) for steam generation?

- Combined cycle power plants.
- All thermal power plants using coal.
- Nuclear power plants.
- Power plants using fluidized bed combustion.

Select the correct answer using the codes given below:

- 1 and 2
- 3 and 4
- 1 and 3
- 2 and 4

[ESE : 1998]

- 1.21 Once-through boilers will not have

- Drums, headers and pumps
- Drums, steam separators and pumps
- Drums, headers and steam separators
- Drums, headers, steam separators and pumps [ESE : 1998]

- 1.22 The characteristics of centrifugal fan are shown in the given figure. The curves (in the figure) representing total head and static head characteristics are respectively

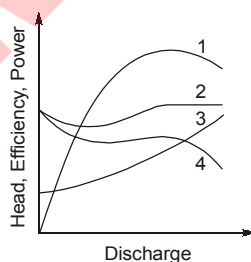

- 1 and 2
- 3 and 4
- 1 and 3
- 2 and 4

[ESE : 1998]

- 1.23 At constant efficiency, the horse power of a fan is

- Proportional to rpm
- proportional to $(rpm)^2$
- Proportional to $(rpm)^3$
- A polynomial function of rpm [ESE : 1998]

- 1.24 Match List-I (Name of boiler) with List-II (Special features) and select the correct answer using the codes given below the lists:

List-I

- Lancashire
- Cornish
- La-Mont
- Cochran

List-II

- High pressure water tube
- Horizontal double fire tube
- Vertical multiple fire tube
- Low pressure inclined water tube
- Horizontal single fire tube

Codes:

- | | A | B | C | D |
|-----|---|---|---|---|
| (a) | 2 | 5 | 1 | 3 |
| (b) | 2 | 4 | 3 | 1 |
| (c) | 1 | 5 | 2 | 3 |
| (d) | 5 | 4 | 1 | 3 |

[ESE : 1999]

- 1.25 The p-V diagram for the reciprocating steam engine is shown in the figure. The length A-B represents the

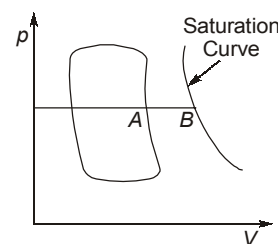

- Condensation loss
- Friction loss
- Missing quantity
- Dryness fraction [ESE : 1999]

- 1.26 Benson boiler is one of the high pressure boilers having

- One drum
- One water drum and one steam drum
- Three drums
- No drum [ESE : 1999]

1.27 Which one of the following safety devices is used to protect the boiler when the water level falls below a minimum level?

- (a) Water level indicator (b) Fusible plug
(c) Blow off cock (d) Safety valve

[ESE : 1999]

1.28 Forced draught fans of a large steam generator have

- (a) Backward curved blades
(b) Forward curved blades
(c) Straight or radial blades
(d) Double curved blades

[ESE : 1999]

1.29 Consider the following statements :

1. Pulverized fuel gives high and controlled burning rate.
2. Insufficient air causes excessive smoking of exhaust.
3. Excess air is provided to control the flue gas temperature.
4. Effect of sulphur in fuel is to give high heat transfer rate.

Which of these statements are correct?

- (a) 3 and 4 (b) 2 and 3
(c) 1 and 2 (d) 1 and 4

[ESE : 1999]

1.30 The device used to heat feed-water by utilizing the heat of the exhaust flue gases before leaving through the chimney, is called

- (a) Superheater (b) Economizer
(c) Air preheater (d) ID fan

[ESE : 1999]

1.31 Assertion (A): In infrared gas analyser, the amount of absorption is the function of concentration of the gas and the length of the absorption path.

Reason (R): Different gases are characteristic by distinctive absorption bands within the infrared range.

- (a) Both **A** and **R** are individually true and **R** is the correct explanation of **A**
(b) Both **A** and **R** are individually true but **R** is not the correct explanation of **A**
(c) **A** is true but **R** is false
(d) **A** is false but **R** is true

[ESE : 1999]

■ ■ ■ ■

Answers Thermal Power Plant Components

- 1.1 (c) 1.2 (d) 1.3 (d) 1.4 (d) 1.5 (c) 1.6 (d) 1.7 (d) 1.8 (c) 1.9 (a)
1.10 (c) 1.11 (b) 1.12 (d) 1.13 (d) 1.14 (a) 1.15 (a) 1.16 (d) 1.17 (d) 1.18 (a)
1.19 (a) 1.20 (c) 1.21 (c) 1.22 (d) 1.23 (c) 1.24 (a) 1.25 (c) 1.26 (d) 1.27 (b)
1.28 (a) 1.29 (c) 1.30 (b) 1.31 (a)

Explanations Thermal Power Plant Components

1.1 (c)

Fire tube boilers:

- (i) Locomotive boiler (Horizontal boiler)
- (ii) Lancashire boiler
- (iii) Scotch marine boiler
- (iv) Cochran boiler (vertical boiler)

Water tube boilers:

- (i) Babcox-Wilcox boiler
- (ii) Lamont boiler (high pressure boiler with forced circulation)
- (iii) Benson boiler (high pressure boiler)

1.2 (d)

The equipments used for safe working of the boiler are known as mountings. Following is the list of mountings which are normally used on the boiler.

(a) For control of water and steam

1. Feed check valve
2. Steam stop valve

(b) For safety of boiler

1. Pressure gauge
2. Water level indicator
3. Safety valve
4. Fusible plug

(c) For cleaning and maintenance purpose

1. Man hole

Boiler accessories are provided to improve the efficiency of the plant.

The commonly used accessories are:

1. Superheater
2. Economiser
3. Air preheater
4. Feed pump
5. Steam separator

1.3 (d)

Electrostatic precipitator: The function of electrostatic precipitator is to collect the fly ash particles from the flue gases by electrostatic principle. Sodium zeolite is a method of feed water purification.

Blow down: Blow down is a process of removing solid precipitates at boiler drum bottom.

1.4 (d)

As the pressure parameter of steam increases forced circulation is required because as pressure increases the density difference between steam and water decreases, so natural circulation is not possible.

1.5 (c)

Boiler mounting is used for safety purpose of boiler.

1.6 (d)

Circulation ratio is defined as reciprocal of percentage steam supplied in drum.

$$\text{Circulation ratio: } CR = \frac{m_g + m_l}{m_g} = 1 + \frac{m_l}{m_g}$$

where

m_l = Mass of liquid water at the riser exit.

m_g = mass of saturated steam released from the drum during the same time.

$$CR = 1 + \frac{0.9}{0.1} = 1 + 9 = 10$$

1.7 (d)

Draught in mm of water column is

$$h = \frac{353H}{T_1} \left[1 - \frac{m+1}{m} \times \frac{T_1}{T_g} \right]$$

$$= \frac{353H}{T_1} \left[1 - \frac{m+1}{m} \times \frac{m}{2(m+1)} \right]$$

$$= \frac{353H}{2T_1} = \frac{176.5H}{T_1}$$

1.8 (c)

Fuel	Excess Air(%)
Anthracite	40%
Coal, Pulverized	15-20%
Coal, Stoker	20-30%
Semi anthracite with travelling grate	30-60%

1.9 (a)

Heat transfer to water wall is predominately by radiation.

$$E = \epsilon \sigma AT^4$$

1.10 (c)

Expansion joints are not provided for future expansion of the plant but it is provided to take care of temperature stresses.

1.11 (b)

Main objective of condenser is to extract only latent heat of steam. Due to under cooling (sub-cooling) the efficiency of plant reduces.

1.12 (d)

Hydroelectric plants are capital intensive with a low rate of return. The interest rate of this capital cost is large part of annual cost.

1.13 (d)

An open feed water heater or deaerator is one in which the feed water is heated by direct mixing with steam bled from turbine. It is used to remove dissolved gases in feed water particularly oxygen.

1.14 (a)

Backward curved blade will give higher efficiency.

1.15 (a)

In mechanical draught, air is forced to furnace through duct and APH. Thus utilising the exhaust heat of flue gas.

1.16 (d)

The correct sequence of the flow of flue gases are superheater, Economiser, Air-heater and I.D. fan.

1.17 (d)

In Benson boiler, feed pump feeds water to economiser from where it goes to radiant heating section. Here most of the heat is transmitted and water gets heated almost to the critical temperature. In the evaporative section, the evaporation is completed and superheating begins. Superheating is done by convection superheater and radiation superheater. After superheater the final desired temperature is obtained.

1.18 (a)

Coal fired power plant boilers manufactured in India generally use pulverized fuel combustion.

1.20 (c)

In nuclear power plant, energy is liberated due to unfired nuclear chain reaction. Heat recovery steam generator is used in combined cycle power plant.

1.21 (c)

Benson boiler is a typical high pressure, drum less, water tube, forced circulated once through boiler. It has a unique characteristic of absence of drum entire process of heating, steam formation and superheating is done in a single continuous tube. Feeds pumps feeds water to economiser from where it goes to radiant heating section.

1.23 (c)

Similarity law of fan.

$$\frac{P}{N^3 D^5 \rho} = \text{constant}$$

P = Power, N = Rotational speed

D = Impeller diameter

ρ = Density of fluid

1.25 (c)

Missing quantity is mainly due to the condensation of steam and a small amount will be due to leakage past the piston.

1.26 (d)

Benson boiler is a typical high pressure, water tube, forced circulated once through boiler. This boiler does not have any drum.

1.27 (b)

The function of a fusible plug is to extinguish the fire of the furnace when the water level inside the boiler falls to a dangerously low level. If this is not done the boiler tubes and shell may be damaged due to overheating or the boiler may explode.

1.28 (a)

Forced draught fans of a large steam generator have backward curved blades because these have steep head characteristics, good efficiency, high speed and ability to operate in parallel.

1.29 (c)

Excess air is provided for complete combustion. Smoke is formed due to formation of carbon mono oxide.

1.30 (b)

Economiser is situated before air pre-heater in the flue gas path.

■■■■

2.1 At which location of a converging-diverging nozzle, does the shock-boundary layer interaction take place?

- (a) Converging portion (b) Throat
(c) Inlet (d) Diverging portion

[ESE : 1995]

2.2 The effect of friction in a steam nozzle is to

- (a) increases velocity and increase dryness fraction
(b) increases velocity and decreases dryness fraction
(c) decreases velocity and increases dryness fraction
(d) decreases velocity and decreases dryness fraction

[ESE : 1995]

2.3 Consider the following statements pertaining to isentropic flow:

- To obtain stagnation enthalpy, the flow need not be decelerated isentropically, but should be decelerated adiabatically.
- The effect of friction in an adiabatic flow is to reduce the stagnation pressure and to increase entropy.
- A constant area tube with rough surface can be used as a subsonic nozzle.

Which of these statements are correct?

- (a) 1, 2 and 3 (b) 1 and 2
(c) 1 and 3 (d) 2 and 3

[ESE : 1996]

2.4 Consider the following statements :

A convergent-divergent nozzle is said to choked when

- Critical pressure is attained at the throat.
- Velocity at throat becomes sonic.
- Exit velocity becomes supersonic.

Which of these statements are correct?

- (a) 1, 2 and 3 (b) 1 and 2
(c) 2 and 3 (d) 1 and 3

[ESE : 1996]

2.5 In flow through a convergent nozzle, the ratio of back pressure to the inlet pressure is given by the relation

$$\frac{p_B}{p_1} = \left(\frac{2}{\gamma + 1} \right)^{\frac{\gamma}{\gamma - 1}}$$

If the back pressure is lower than p_B given the above equation, then

- (a) the flow in the nozzle is supersonic
(b) a shock wave exists inside the nozzle
(c) the gases expand outside the nozzle and a shock wave appears outside the nozzle
(d) a shock wave appears at the nozzle exit

[ESE : 1996]

2.6 Assertion (A): For pressure ratio greater than the critical pressure ratio, a convergent-divergent nozzle is required

Reason (R): Divergent portion increases the flow area which increases the mass flow rate.

- (a) Both **A** and **R** are individually true and **R** is the correct explanation of **A**
(b) Both **A** and **R** are individually true but **R** is not the correct explanation of **A**
(c) **A** is true but **R** is false
(d) **A** is false but **R** is true

[ESE : 1996]

2.7 Consider the following statements:

When dry saturated or slightly superheated steam expands through a nozzle

- the coefficient of discharge is greater than unity.
- it is dry upto Wilson's line.
- expansion is isentropic throughout.

Which of these statements are correct?

- (a) 1, 2 and 3 (b) 1 and 2
(c) 1 and 3 (d) 2 and 3

[ESE : 1997]

- 2.8** The total and static pressures at the inlet of a steam nozzle are 186 kPa and 178 kPa respectively. If the total pressure at the exit is 180 kPa and static pressure is 100 kPa, then the loss of energy per unit mass in the nozzle will be
 (a) 78 kPa (b) 8 kPa
 (c) 6 kPa (d) 2 kPa

[ESE : 1997]

- 2.9** Match **List-I** with **List-II** and select the correct answer using the codes given below the lists:

List-I	List-II
A. Slip	1. Reduction of whirl velocity
B. Stall	2. Fixed mass Flow rate regardless of pressure ratio
C. Choking	3. Flow separation
	4. Flow area separation

Codes:

	A	B	C
(a)	4	3	2
(b)	1	3	2
(c)	4	1	3
(d)	2	3	4

[ESE : 1997]

- 2.10** Match **List-I** (Property ratios as the critical and stagnation conditions) with **List-II** (Values of ratios) and select the correct answer using the codes given below the lists:

List-I	List-II
A. $\frac{T^*}{T_0}$	1. $\left(\frac{2}{\gamma+1}\right)^{\frac{1}{\gamma-1}}$
B. $\frac{\rho^*}{\rho_0}$	2. $\frac{2}{\gamma+1}$
C. $\frac{P^*}{P_0}$	3. 1
D. $\frac{S^*}{S_0}$	4. $\left(\frac{2}{\gamma+1}\right)^{\frac{\gamma}{\gamma-1}}$

Codes:

	A	B	C	D
(a)	2	1	4	3
(b)	1	2	3	4
(c)	2	1	3	4
(d)	1	2	4	3

[ESE : 1997]

- 2.11** The stagnation temperature of an isentropic flow of air ($k = 1.4$) is 400 K. If the temperature is 200 K at a section, then the Mach number of the flow will be

- (a) 1.046 (b) 1.264
 (c) 2.236 (d) 3.211

[ESE : 1998]

- 2.12** In isentropic flow between two points, the stagnation

- (a) pressure and stagnation temperature may vary
 (b) pressure would decrease in the direction of the flow
 (c) pressure and stagnation temperature would decrease with an increase in velocity
 (d) pressure, stagnation temperature and stagnation density would remain constant throughout the flow.

[ESE : 1998]

- 2.13** Under ideal conditions, the velocity of steam at the outlet of a nozzle for a heat drop of 400 kJ/kg will be approximately.

- (a) 1200 m/s
 (b) 900 m/s
 (c) 60 m/s
 (d) the same as the sonic velocity

[ESE : 1998]

- 2.14** Consider the following statements:

- De Laval nozzle is a subsonic nozzle.
- Supersonic nozzle is a converging passage.
- Subsonic diffuser is a diverging passage.

Which of these statements is/are correct?

- (a) 1 and 2 (b) 2 and 3
 (c) 1 only (d) 3 only

[ESE : 1999]

- 2.15** In a steam nozzle, inlet pressure of superheated steam is 10 bar. The exit pressure is decreased from 3 bar to 1 bar. The discharge rate will

- (a) Remain constant
 (b) Decrease
 (c) Increase slightly
 (d) Increase or decrease depending on whether the nozzle is convergent or convergent-divergent

[ESE : 1999]

Answers Nozzles

2.1 (d) 2.2 (c) 2.3 (a) 2.4 (b) 2.5 (c) 2.6 (d) 2.7 (b) 2.8 (c) 2.9 (b)
2.10 (a) 2.11 (c) 2.12 (c) 2.13 (b) 2.14 (d) 2.15 (a)

Explanations Nozzles**2.1 (d)**

Due to very high velocity at diverging section, the mach number at the diverging section is greater than unity hence shock occurs at diverging section.

2.2 (c)

Due to fluid friction the expansion process is not isentropic, but is irreversible and adiabatic ($Q = 0$). Friction reduces the enthalpy drop by 10 to 15% and thus reducing the exit velocity. Being adiabatic condition, the heat generated due to friction goes back to steam and improves the dryness friction at exit due to heating effect.

2.3 (a)

To obtain stagnation pressure, the flow necessarily decelerated isentropically, but for stagnation enthalpy flow can be deaccelerated adiabatically.

2.4 (b)

A convergent-divergent nozzle is said to choked (maximum mass flow) when velocity at throat becomes sonic (Mach number = 1) and critical pressure is attained at the throat.

2.5 (c)

There will be a design pressure at the exit of the nozzle at which flow through the nozzle will be very smooth.

When the exit pressure is less than the design pressure, the fluid will expand outside the nozzle and shock wave will appear at the exit of the nozzle or at the entry of the turbine.

2.6 (d)

In convergent-divergent nozzle, exit pressure is less than critical pressure hence convergent

divergent nozzle is not required for exit pressure higher than critical pressure

2.7 (b)

Coefficient of discharge is greater than unity because discharge increases. This is the phenomenon of "super saturation".

2.8 (c)

Total pressure at inlet = Total pressure at exit + Losses of energy
186 = 180 + losses of energy
 \therefore loss of energy = **6 kPa**

2.9 (b)

$$\text{Slip} = \frac{\text{Actual whirl velocity}}{\text{Ideal whirl velocity}}$$

Stall = Flow separation

2.10 (a)

$$\frac{T_0}{T} = 1 + \frac{\gamma - 1}{2} \cdot M^2$$

For critical condition

$$M = 1$$

$$\frac{T_0}{T^*} = \frac{\gamma + 1}{2}$$

$$\Rightarrow \left(\frac{T^*}{T_0} \right) = \frac{2}{\gamma + 1}$$

$$\therefore \frac{P_2}{P_1} = \left(\frac{T_2}{T_1} \right)^{\gamma/(\gamma-1)}$$

$$\Rightarrow \frac{P^*}{P_0} = \left(\frac{T^*}{T_0} \right)^{\gamma/(\gamma-1)}$$

$$\therefore \frac{P^*}{P_0} = \left(\frac{2}{\gamma + 1} \right)^{\gamma/(\gamma-1)}$$

2.11 (c)

$$\frac{T_0}{T} = 1 + \left(\frac{\gamma-1}{2}\right)M^2$$

$$\frac{400}{200} = 1 + \left(\frac{1.4-1}{2}\right)M^2$$

$$M = \sqrt{5} \approx 2.236$$

2.12 (c)

In isentropic flow between two points. The stagnation pressure and stagnation temperature would decrease with an increase in velocity.

2.13 (b)

$$V = \sqrt{2(h_2 - h_1)} = \sqrt{2 \times 400 \times 10^3}$$

$$= 894.42 \text{ m/s} \approx 900 \text{ m/s}$$

2.14 (d)

Supersonic nozzle is a diverging passage

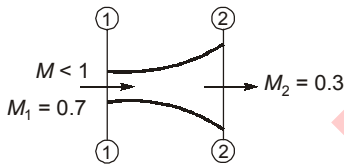

Subsonic Diffuser

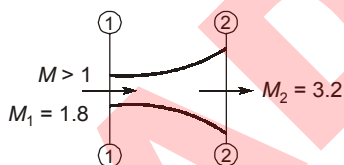

Supersonic Nozzle

2.15 (a)

When steam is flowing through nozzle then the critical pressure ratio is

$$\frac{P_c}{P_1} = \left(\frac{2}{n+1}\right)^{\frac{n}{n-1}}$$

where

$n = 1.3$ for superheated steam

$n = 1.135$ for dry saturated steam

For superheated steam

$$\frac{P_c}{P_1} = \left(\frac{2}{1+1.3}\right)^{\frac{1.3}{0.3}}$$

$$P_c = 0.546 P_1 = 0.546 \times 10 = 5.46 \text{ bar}$$

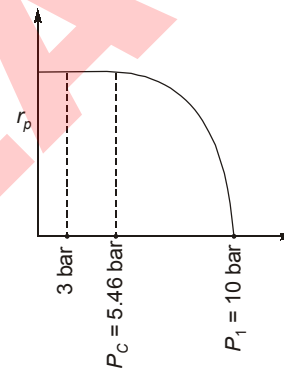

Since critical condition is reached, hence further decrease in pressure will not affect the mass flow rate.



3.1 Which one of the following pairs of materials is used as moderators in nuclear reactors?

- (a) Heavy water and zirconium
- (b) Zirconium and beryllium
- (c) Cadmium and beryllium
- (d) Beryllium and heavy water [ESE : 1995]

3.2 Which one of the following pairs is not correctly matched?

- (a) Fertile material ... U-233
- (b) Atomic number Number of protons
- (c) Mass defect Binding energy
- (d) Cross-section Scattering [ESE : 1995]

3.3 The energy released during the fission of one atom of Uranium-235 in million electron volts is about

- (a) 100
- (b) 200
- (c) 300
- (d) 400 [ESE : 1995]

3.4 Consider the following statements:

1. Gas cooled thermal reactors use CO_2 or helium as coolant and require no separate moderator.
2. Fast reactors use heavy water as moderator and coolant.
3. Liquid metal fast breeder reactors use molten sodium as coolant.
4. In Candu type reactors heavy water is used as moderator.

Which of these statements are correct?

- (a) 1 and 3
- (b) 2 and 4
- (c) 3 and 4
- (d) 1 and 2 [ESE : 1996]

3.5 Match **List-I** with **List-II** and select answer using the codes given below the lists:

List-I

- A. Plutonium-239
- B. Thorium-233
- C. Cadmium
- D. Graphite

List-II

1. Fissile material

2. Fissionable material

3. Moderator

4. Poison

Codes:

	A	B	C	D
(a)	1	2	3	4
(b)	2	1	3	4
(c)	1	2	4	3
(d)	2	1	4	3

[ESE : 1996]

3.6 Consider the following statements :

CANDU-type nuclear reactor using natural uranium finds extensive use because

1. Heavy water is used both as coolant and moderator.
2. Cost of fuel used is much lower than that used in pressurized water or boiling water reactor.
3. Small leakage of heavy water does not affect the performance of the reactor substantially.
4. Fuel consumption is low because of use of heavy water.

Which of these statements are correct?

- (a) 1, 2, 3 and 4
- (b) 1, 2 and 4
- (c) 1 and 2
- (d) 3 and 4

[ESE : 1997]

3.7 Match **List-I** with **List-II** and select the correct answer using the codes given below the lists:

List-I

- A. Prepared fuel
- B. Primary fuel
- C. Moderator
- D. Control rod

List-II

1. Uranium-235
2. Graphite
3. Uranium-233
4. Cadmium

Codes:

	A	B	C	D
(a)	1	3	2	4
(b)	3	1	4	2
(c)	3	1	2	4
(d)	1	3	4	2

[ESE : 1997]

3.8 Consider the following statements regarding nuclear reactors:

1. In a gas-cooled thermal reactor, if CO_2 is used as the coolant, a separate moderator is not necessary as the gas contains carbon.
2. Fast reactors using enriched uranium fuel do not require a moderator.
3. In liquid metal-cooled fast breeder reactors, molten sodium is used as the coolant because of its high thermal conductivity.
4. Fast reactors rely primarily on slow neutrons for fission.

Which of these statements are correct?

- (a) 1 and 2 (b) 2 and 4
(c) 2 and 3 (d) 1 and 3

[ESE : 1998]

3.9 Assertion (A): The thermal efficiency of a nuclear power plant using a boiling water reactor is higher than of a plant using a pressurized water reactor.

Reason (R): In a boiling water reactor, steam is directly allowed to be generated in the reactor itself, whereas in a pressurized water reactor, steam is generated in a separate boiler by heat exchanger device using water of the primary circuit which absorbs the fission energy.

- (a) Both **A** and **R** are individually true and **R** is the correct explanation of **A**
(b) Both **A** and **R** are individually true but **R** is not the correct explanation of **A**
(c) **A** is true but **R** is false
(d) **A** is false but **R** is true

[ESE : 1999]

■■■■

Answers Nuclear Power Plant

3.1 (d) **3.2** (d) **3.3** (b) **3.4** (c) **3.5** (c) **3.6** (a) **3.7** (c) **3.8** (c) **3.9** (a)

Explanations Nuclear Power Plant

3.1 (d)

Materials used as moderator are ordinary hydrogen (H-1) heavy hydrogen (H-2) beryllium and carbon.

3.2 (d)

The newly born fission neutrons have energies varying between 0.075 to 17 MeV. As these neutrons travel through matter, they collide with other nuclei and get slowed down. This process is called scattering.

3.3 (b)

The fission of U-235 yields on an average about 193 MeV, which is the same for the fission of U-233 and Pu-239. This amount of energy is prompt, i.e. released during the fission process.

3.4 (c)

In gas cooled reactor, both natural and enriched uranium fuel with CO_2 as a coolant and graphite as moderator are used.

The best coolants for fast reactors are liquid metals such as Sodium. Liquid metal have the additional advantage that their boiling points at

atmospheric pressure are very high, so most of them can be used unpressurized in a reactor. Sodium is the most common coolant for fast reactors.

3.5 (c)

Fissile materials:

Pu-239, Pu-241, U-233, U-235, U-239 etc.

Fertile materials:

Th-232, U-234, U-238, Pu-238, Pu-240

Commonly used moderators: Water, heavy water, graphite, beryllium etc.

3.6 (a)

Advantages of CANDU Reactor:

1. Heavy water is used as moderator and coolant which has higher multiplication factor and low level consumption.
2. Enriched fuel is not required
3. The cost of the vessel is less due to low pressure in it.
4. Construction time is less
5. Moderator can be kept at low temperature which increases its effectiveness in slowing down neutron.

3.7 (c)

Uranium-233 is a fissile **artificial** isotope of uranium, part of thorium fuel cycle. It is produced by neutron irradiation of Thorium-232.

3.8 (c)

In a gas cooled thermal reactor CO_2 gas as coolant and graphite as moderator is used.

In liquid metal fast breeder reactor, liquid sodium is used as coolant and no moderator is required.

3.9 (a)

Boiling water reactor

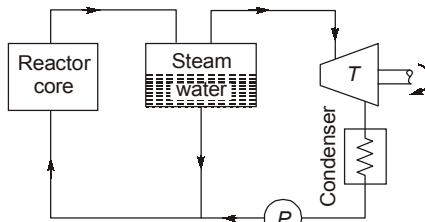

Pressurised water reactor

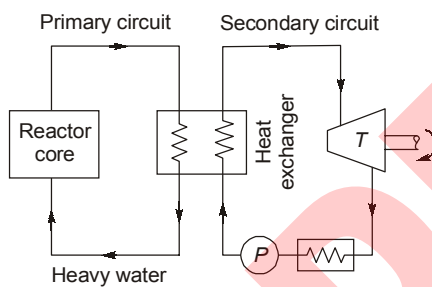

In boiling water reactor, steam coming out through the reactor core is allowed to expand in the turbine and after condensation water is again fed to the core, this reduces the loss during the heat exchange process.

While in pressurised water reactor heavy water is used to carry out the heat from the reactor core and through the heat exchanger steam is generated, and due to two separate circuits losses are more in pressurised water reactor. ■■■■

- 4.1 The mass of air required for complete combustion of unit mass of fuel can always be calculated from the formula, where C, H, O and S are in percentage
- $0.1152 C + 0.3456 H$
 - $0.1152 C + 0.3456 (H - 0.125 O)$
 - $0.1152 C + 0.3456 (H - 0.125 O) + 0.0432 S$
 - $0.1152 C + 0.3456 (H + 0.125 O) + 0.0432 S$

[ESE : 1995]

- 4.2 Consider the following statements
The maximum temperature produced by the combustion of a unit mass of fuel depends upon

- Calorific value.
- Ash content.
- Mass of air supplied.
- Pressure in the furnace.

Which of these statements is/are correct?

- 1 only
- 1 and 3
- 2 and 4
- 3 and 4

[ESE : 1998]

- 4.3 Match **List-I** (The T - s diagram of the thermodynamic cycles) with **List-II** (Names of cycles) and select the correct answer using the codes given below the lists:

List-I

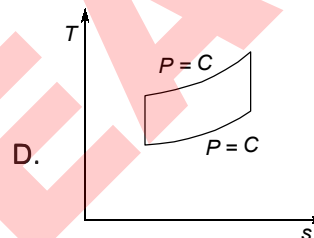
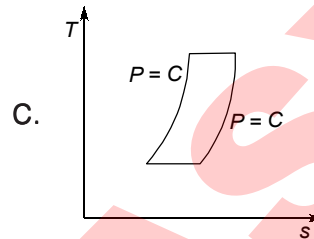
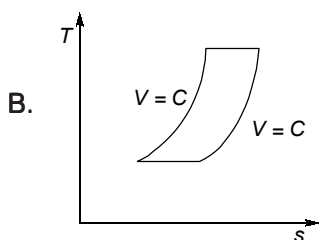
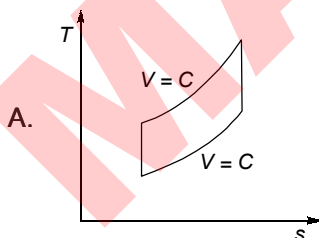

List-II

- Brayton Cycle
- Otto cycle
- Stirling cycle
- Ericsson cycle
- Diesel cycle

Codes:

	A	B	C	D
(a)	1	4	5	2
(b)	1	3	4	5
(c)	2	4	5	1
(d)	2	3	4	1

[ESE : 1999]

- 4.4 Match **List-I** (name of cycles) with **List-II** (p - v -diagram) and select the correct answer using the codes given below the lists:

List-I

- Stirling cycle
- Diesel cycle
- Otto cycle
- Atkinson cycle

List-II

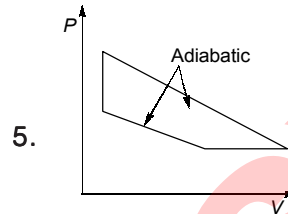
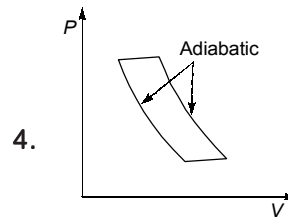
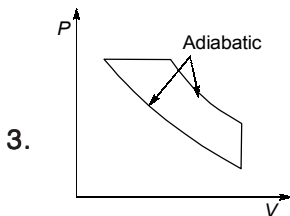
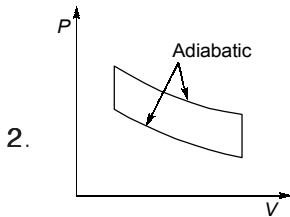
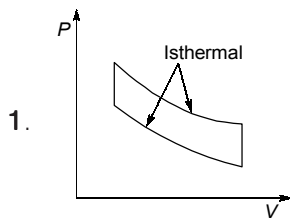

Codes:

	A	B	C	D
(a)	2	3	1	5
(b)	1	3	2	4
(c)	2	3	1	4
(d)	1	3	2	5

[ESE : 1999]

Answers Miscellaneous

4.1 (c) 4.2 (b) 4.3 (d) 4.4 (d)

Explanations Miscellaneous

4.1 (c)

$$\begin{aligned} \text{For per kg of fuel, } W_T &= \frac{W_{O_2}}{0.232} \\ &= \frac{2.67}{0.232} + \frac{8}{0.232} \left(H - \frac{O}{8} \right) + \frac{1}{0.232} S \\ &= 11.5C + 34.5 \left(H - \frac{O}{8} \right) + 4.31S \end{aligned}$$

4.2 (b)

Calorific value: Quantity of heat liberated on complete combustion of a unit weight of fuel. Mass of air decides the extent of combustion.

4.3 (d)

(1) Otto cycle : Two adiabatics and two constant volumes

(2) Ericsson cycle : Two isothermals and two isobars

(3) Stirling cycle : Two isothermals and two constant volumes

(4) Diesel Cycle : Two adiabatics and one constant volume and one constant pressure

4.4 (d)

Stirling cycle : Two isothermals and two constant volumes

Atkinson cycle : Two adiabatics, one constant volume and one constant pressure